

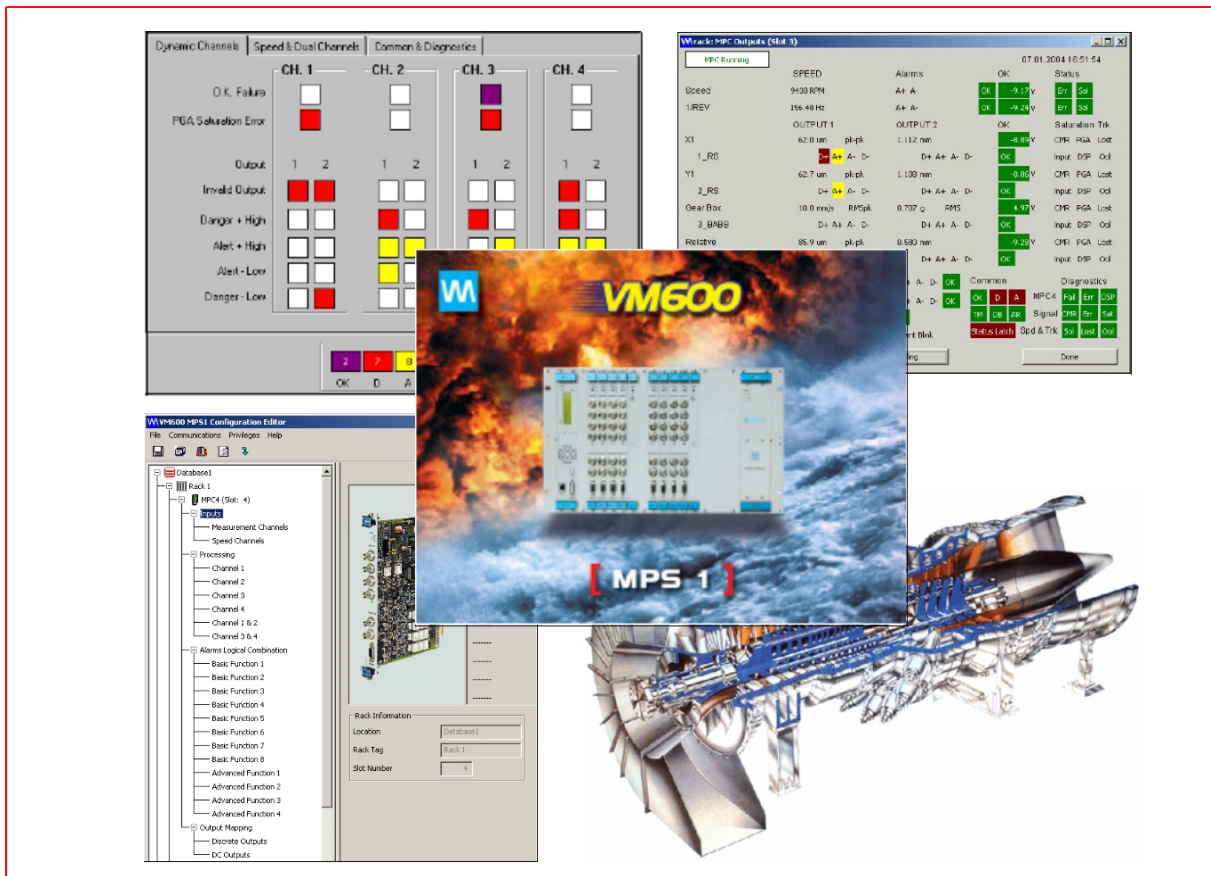

## SOFTWARE MANUAL

### VM600 MPS1 Configuration Software for Machinery Protection Systems



**Meggitt SA**  
Route de Moncor 4  
PO Box 1616  
CH - 1701 Fribourg  
Switzerland

## REVISION RECORD SHEET

Edition	Date of issue	Written / modified by	PM no.	Description	Signature
1	19.05.00	R. Meyer	---	Original edition (Software Release 1.00).	RM
2	14.12.01	R. Meyer	---	General revision for Software Release 1.30. Appendix A : included more information on the vi editor.	RM
3	05.03.04	R. Meyer	---	General revision for Software Release 1.5.010	RM
4	9.6.05	R. Rice	---	General revision for Software Release 2.0.009.	RR
5	31.03.06	N. Parker	---	Update for new corporate identity	NP
6	04.04.08	D. Evans	---	Updated cut-off frequency in section 8	DE
7	15.12.2009	P. Ward	---	Updated Installation Procedure (section 3). Also updated Customer Support information.	PW
8	16.12.2013	P. Ward	---	For VM600 MPS software version 2.5.xxx, updated 6 Main window menus and commands to reflect changes to the user interface and include the Sensor Information Editor, updated 7 Input configuration (MPC4 and MPC4 SIL) to include new copy operations for MPC4 card configurations (7.4 Copying card configurations), updated 8.3.19 Dual mathematical function to include new mathematical functions, and updated 11 Communications menu (MPC4 and MPC4 SIL) and 15 Communications menu (AMC8) to include the channel inhibit function. Also applied the latest Meggitt style guidelines.	PW
9	13.05.2015	P. Ward	---	For VM600 MPS software version 2.6.xxx, updated to include information on the improved support for the MPC4 SIL, that is, the safety version of the MPC4 card (see 2.2 VM600 MPS configuration, 2.3 Configuring individual cards, 5.4 Adding cards to a rack, 6.4 Managing MPC4 and MPC4 SIL cards (card overview page) and 8.3 Additional information on processing functions). Corrected the specification of the decay time in Rectifier Response or Decay Time (8.4 Parameter fields found on the "Processed Output" tabs).	PW
10	09.06.2015	P. Ward	---	For VM600 MPS software version 2.7.xxx, updated to include information on VM600 MPS rack (CPUM) security (see 4.3 VM600 MPS rack (CPUM) security, 6.3 Managing racks and 6.4 Managing MPC4 and MPC4 SIL cards (card overview page)) and CPUM Configurator (4.4 CPUM Configurator software). Updated the description of the Invalid Output flag and the screen shots in 9 Defining logical combinations of alarms (MPC4 and MPC4 SIL). Clarified the use of micro-switches to configure the relays on an IOC8T card as NE/NDE (see 14.2 Mapping alarms (discrete outputs)).	PW

Edition	Date of issue	Written / modified by	PM no.	Description	Signature
11	11.07.2016	P. Ward	---	For VM600 MPS software version 2.7.020, clarified the range of alarm delay values that are supported by the measurement channels of the MPC4 and AMC8 cards (see 8.5.2 Configuring Alert and Danger parameters and 12.3.3.2 Explanation of fields).	PW

	Department	Name	Date	Signature
Technical content of original issue approved by	Engineering	Alexandre Perriard	11.07.2016	IK
	Product Management	Michaël Hafner	11.07.2016	MH
Document released by	Technical Publications	Peter Ward	11.07.2016	PW

*The duly signed master copy of this page is stored by the Technical Publications Department of Meggitt SA and can be obtained by writing to the Technical Publications Manager.*

### **IMPORTANT NOTICE**

All statements, technical information, and recommendations in this document which relate to the products supplied by Meggitt Sensing Systems are based on information believed to be reliable, but unless otherwise expressly agreed in writing with Meggitt SA the accuracy or completeness of such data is not guaranteed. Before using this product, you must evaluate it and determine if it is suitable for your intended application. Unless otherwise expressly agreed in writing with Meggitt SA, you assume all risks and liability associated with such use. Meggitt Sensing Systems takes no responsibility for any statements related to the product which are not contained in a current English language Meggitt Sensing Systems publication, nor for any statements contained in extracts, summaries, translations or any other documents not authored and produced by Meggitt Sensing Systems.

### **EXPORT CONTROL**

The information contained in this document may be subject to export control regulations of the European Community, USA or other countries. Each recipient of this document is responsible for ensuring that the transfer or use of any information contained in this document complies with all relevant export control regulations. ECN N/A.

### **COPYRIGHT**

Copyright© 2000-2016 Meggitt SA

All rights reserved

Published and printed by Meggitt SA in Fribourg, Switzerland

The names of actual companies and products described herein may be the trademarks of their respective owners.

The information contained in this document is subject to change without notice.  
This information shall not be used, duplicated or disclosed, in whole or in part,  
without the express written permission of Meggitt Sensing Systems.

## PREFACE

### About this manual

This manual relates to the VM600 MPS1 Configuration Software, from Meggitt Sensing Systems' Vibro-Meter® product line. It explains how to install and begin using the software, and provides instructions on configuring the system.

---

**NOTE:** This document should be read in conjunction with the following Meggitt Sensing Systems (MSS) manuals:

- *VM600 Machinery Protection System (MPS) hardware manual*
  - *VM600 Networking manual.*
- 

For information on the VM600 MPS2 Configuration Software, refer to the *VM600 MPS2 Configuration Software for Machinery Protection Systems* software manual.

The VM600 MPSx software (that is, MPS1 and MPS2) includes context-sensitive offline help. This means that the help is installed locally on the computer (when the software is installed) and that the text that appears depends on which part of the software is being displayed at the time.

### About Meggitt, Meggitt Sensing Systems and Vibro-Meter

Headquartered in the UK, Meggitt PLC is a global engineering group specialising in extreme environment components and smart sub-systems for aerospace, defence and energy markets.

Meggitt Sensing Systems is the operating division of Meggitt specialising in sensing and monitoring systems, which has operated through its antecedents since 1927 under the names of ECET, Endevco, Ferroperm Piezoceramics, Lodge Ignition, Sensorex, Vibro-Meter and Wilcoxon Research. Today, these operations are integrated under one strategic business unit called Meggitt Sensing Systems, headquartered in Switzerland and providing complete systems, using these renowned brands, from a single supply base.

The Meggitt Sensing Systems facility in Fribourg, Switzerland was formerly known as Vibro-Meter SA, but is now Meggitt SA. This site produces a wide range of vibration and dynamic pressure sensors capable of operation in extreme environments, leading-edge microwave sensors, electronics monitoring systems and innovative software for aerospace and land-based turbo-machinery. This includes the VM600 MPSx Configuration Software (MPS1 software) produced for the Vibro-Meter product line.

### Who should use this manual?

This manual is intended for operators of machinery protection systems using the VM600 MPS1 software.

## Applicability of this manual

---

**NOTE:** This manual applies to version 2.7.xxx of the VM600 MPS1 software. It reflects the features available with version 2.7.xxx and may not be applicable to earlier or later versions of the software.

---

## Terminology

---

**NOTE:** The MPC4 machinery protection card is available in different versions, including a standard version, a separate circuits version and a safety (SIL) version.

---

The MPC4 SIL (safety MPC4 card) was developed to permit a wider range of installation options with a single VM600 rack, for example, condition monitoring in addition to machinery protection. Accordingly, the MPC4 SIL does not have a VME bus interface and can only be configured via a direct connection to the RS-232 connector on its front panel (even for a “networked” VM600 rack), in order to reduce the possibility of corruption of its configuration. In addition, the MPC4 SIL does not provide all of the signal processing capabilities of the standard and the separate circuits versions of the MPC4. Refer to the *MPC4 machinery protection card* data sheet and the *VM600 Machinery Protection System (MPS)* hardware manual for further information.

---

**NOTE:** Previously, the VM600 MPSx software referred to all versions of the MPC4 card as MPC4. Starting with VM600 MPSx software version 2.6, the VM600 MPSx software makes a distinction between different versions of the MPC4 card by referring to both the standard version and the separate circuits version of the MPC4 card as an **MPC4** and referring to the safety version of the MPC4 card as an **MPC4 SIL**.

---

For example, when adding an MPC4 card to a VM600 rack configuration, the user must select either:

- **MPC4** – to add a standard or a separate circuits MPC4 card.
- **MPC4 SIL** – to add a safety MPC4 card.

This distinction continues throughout the VM600 MPSx software, where MPC4 cards are listed as either MPC4 or MPC4 SIL.

In general, MPC4 is used in this manual to refer to all versions of the card. However, where it is necessary to make a distinction, MPC4 is used to indicate both the standard and separate circuits versions of the card and MPC4 SIL is used to indicate the safety version.

## Related publications and documentation

Related documents from Meggitt Sensing Systems (MSS) are:

- *VM600 Machinery Protection System (MPS)* hardware manual (MSS document ref. MAMPS-HW/E).
- *VM600 MPS2 Configuration Software for Machinery Protection Systems* software manual (MSS document ref. MAMPS2-SW/E).
- *MPC4 machinery protection card* data sheet (MSS document ref. 268-021).
- *AMC8 analog monitoring card* data sheet (MSS document ref. 268-041).

Operators of networked VM600 MPSs should also refer to the following document:

- *VM600 Networking* manual  
(MSS document ref. MAVM600-NET/E).

Operators of safety-related systems (SRSs) should also refer to the following document:

- *VM600 Functional Safety* manual  
(MSS document ref. MAVM600-FS/E).

## Release notes

Before using the MPS1 software, read the *Release Notes* provided with the MPS1 Software Installation Kit. The release notes are contained in a file called `ReleaseNotes.pdf` on the CD. The *Release Notes* contain information on:

- New features of the latest version
- Resolved problems, known issues and bug fixes
- Compatibility with earlier software versions.

THIS PAGE INTENTIONALLY LEFT BLANK

## SAFETY

### Symbols and styles used in this manual

The following symbols are used in this manual where appropriate:



#### The **WARNING** safety symbol

**THIS INTRODUCES DIRECTIVES, PROCEDURES OR PRECAUTIONARY MEASURES WHICH MUST BE EXECUTED OR FOLLOWED. FAILURE TO OBEY A WARNING CAN RESULT IN INJURY TO THE OPERATOR OR THIRD PARTIES.**



#### The **CAUTION** safety symbol

**This draws the operator's attention to information, directives or procedures which must be executed or followed. Failure to obey a caution can result in damage to equipment.**

---

**NOTE:** This is an example of the NOTE paragraph style. This draws the operator's attention to complementary information or advice relating to the subject being treated.

---

THIS PAGE INTENTIONALLY LEFT BLANK

# TABLE OF CONTENTS

TITLE PAGE ..... i

REVISION RECORD SHEET ..... ii

PREFACE ..... v

SAFETY..... ix

TABLE OF CONTENTS ..... xi

## Part I: Overview

**1 INTRODUCTION ..... 1-1**

1.1 What is MPS1? ..... 1-1

1.2 Offline help ..... 1-1

1.3 Tool tips ..... 1-1

1.4 Basic operating principle of the MPC4 card ..... 1-1

1.5 Basic operating principle of the AMC8 card ..... 1-3

**2 OVERVIEW OF SYSTEM CONFIGURATION ..... 2-1**

2.1 Introduction ..... 2-1

2.2 VM600 MPS configuration ..... 2-1

2.3 Configuring individual cards ..... 2-5

2.3.1 Configuring MPC4 and MPC4 SIL cards ..... 2-5

2.3.2 Configuring AMC8 cards ..... 2-7

2.4 Configuring the rack ..... 2-8

## Part II: Installation and general configuration

**3 INSTALLING THE SOFTWARE ..... 3-1**

3.1 Before starting ..... 3-1

3.1.1 Items delivered ..... 3-1

3.1.2 System requirements ..... 3-1

3.2 Installation procedure ..... 3-2

3.3	Removing an old version of the software	3-4
3.3.1	Precautions concerning databases	3-4
3.3.2	Removing the software	3-4
<b>4</b>	<b>GETTING STARTED</b>	<b>4-1</b>
4.1	Starting the VM600 MPS1 software	4-1
4.2	VM600 MPSx software privilege levels	4-2
4.2.1	Selecting the privilege level	4-3
4.2.2	Changing privilege-level passwords	4-4
4.2.3	Defining privilege-level passwords during the initial installation	4-5
4.3	VM600 MPS rack (CPUM) security	4-6
4.3.1	Using CPUM security	4-7
4.3.2	Displaying CPUM security settings	4-9
4.3.3	Allowing or blocking access to the CPUM	4-10
4.3.4	Enabling and disabling MPS password validation on a CPUM	4-11
4.3.5	Changing the password on the CPUM	4-11
4.3.6	Logging on and off a CPUM	4-11
4.3.7	Resetting the CPUM security settings	4-12
4.4	CPUM Configurator software	4-13
<b>5</b>	<b>CREATING THE CONFIGURATION TREE</b>	<b>5-1</b>
5.1	Introduction	5-1
5.2	Creating databases	5-1
5.3	Adding a rack to a database	5-2
5.4	Adding cards to a rack	5-4
<b>6</b>	<b>MAIN WINDOW MENUS AND COMMANDS</b>	<b>6-1</b>
6.1	Introduction	6-1
6.2	Main window at database level (managing databases)	6-1
6.2.1	Performing consistency checks	6-3
6.2.2	Using the Sensor Information Editor	6-5
6.2.3	Using the Database Manager	6-7
6.3	Managing racks	6-9
6.3.1	Drop-down menus and toolbar (with a rack selected)	6-10
6.3.2	Shortcut menu (with a rack selected)	6-11
6.3.3	Sending a configuration to a VM600 rack or card	6-12

6.4	Managing MPC4 and MPC4 SIL cards (card overview page) . . . . .	6-12
6.4.1	Drop-down menus and toolbar (with an MPC4 or MPC4 SIL card selected) . . . . .	6-14
6.4.2	Shortcut menu (with an MPC4 or MPC4 SIL card selected) . . . . .	6-16
6.5	Managing AMC8 cards (card overview page). . . . .	6-19
6.5.1	Drop-down menus and toolbar (with an AMC8 card selected) . . . . .	6-20
6.5.2	Shortcut menu (with an AMC8 card selected) . . . . .	6-21
6.6	Displaying a customised picture on the card overview page . . . . .	6-21
6.7	Displaying configuration details for cards . . . . .	6-22

## Part III: Configuring MPC4 and MPC4 SIL cards

<b>7</b>	<b>INPUT CONFIGURATION (MPC4 AND MPC4 SIL) . . . . .</b>	<b>7-1</b>
7.1	Introduction . . . . .	7-1
7.2	Configuring measurement channels . . . . .	7-1
7.2.1	Configuration procedure . . . . .	7-1
7.2.2	Additional information on fields. . . . .	7-3
7.3	Configuring speed channels . . . . .	7-4
7.3.1	Configuration procedure . . . . .	7-4
7.3.2	Additional information on fields. . . . .	7-6
7.4	Copying card configurations . . . . .	7-7
<b>8</b>	<b>PROCESSING CONFIGURATION (MPC4 AND MPC4 SIL). . . . .</b>	<b>8-1</b>
8.1	Introduction . . . . .	8-1
8.2	Configuring a processing channel. . . . .	8-1
8.3	Additional information on processing functions. . . . .	8-4
8.3.1	Broad band absolute bearing vibration. . . . .	8-5
8.3.2	Narrow band (tracking) vibration . . . . .	8-5
8.3.3	Relative shaft vibration . . . . .	8-7
8.3.4	Position. . . . .	8-8
8.3.5	Eccentricity . . . . .	8-10
8.3.6	Absolute housing expansion. . . . .	8-11
8.3.7	Relative shaft expansion with pendulum . . . . .	8-12
8.3.8	Broad band pressure . . . . .	8-13
8.3.9	Quasi-static pressure . . . . .	8-14
8.3.10	Quasi-static temperature . . . . .	8-16
8.3.11	Narrow band fixed frequency . . . . .	8-18

8.3.12	$S_{max}$ .....	8-19
8.3.13	Absolute shaft vibration .....	8-21
8.3.14	Differential housing expansion .....	8-22
8.3.15	Relative shaft expansion with shaft taper .....	8-23
8.3.16	Relative shaft expansion with shaft collar .....	8-25
8.3.17	Delta quasi-static pressure .....	8-26
8.3.18	Delta quasi-static temperature .....	8-27
8.3.19	Dual mathematical function .....	8-28
8.4	Parameter fields found on the “Processed Output” tabs .....	8-30
8.5	Configuring alarms .....	8-32
8.5.1	General .....	8-32
8.5.2	Configuring Alert and Danger parameters .....	8-33
8.6	Adaptive monitoring and direct trip multiply .....	8-34
8.6.1	Configuring adaptive monitoring parameters .....	8-34
8.6.2	Configuring direct trip multiply parameters .....	8-36
<b>9</b>	<b>DEFINING LOGICAL COMBINATIONS OF ALARMS (MPC4 AND MPC4 SIL).....</b>	<b>9-1</b>
9.1	Introduction .....	9-1
9.2	Defining a basic alarm function .....	9-1
9.3	Defining an advanced alarm function .....	9-5
<b>10</b>	<b>OUTPUT MAPPING (MPC4 AND MPC4 SIL) .....</b>	<b>10-1</b>
10.1	Introduction .....	10-1
10.2	Mapping alarms (discrete outputs) .....	10-1
10.3	Configuring DC outputs (analog outputs) .....	10-4
<b>11</b>	<b>COMMUNICATIONS MENU (MPC4 AND MPC4 SIL).....</b>	<b>11-1</b>
11.1	Introduction .....	11-1
11.2	Communication with a stand-alone rack (no CPUM present) .....	11-2
11.2.1	Setup procedure .....	11-2
11.2.2	Communicating with an MPC4 card in a stand-alone rack .....	11-3
11.3	Communication with a networked rack (CPUM present) .....	11-4
11.4	Downloading the configuration (Send Configuration) .....	11-5
11.5	Reading the configuration (Read Configuration) .....	11-5
11.6	Testing the communications link (Read System Identification) .....	11-6
11.7	The status latch (clearing and reading) .....	11-6
11.8	The MPC outputs window (Read Outputs) .....	11-9
11.8.1	Explanation of fields .....	11-9

11.9	Resetting alarms (Alarm Reset) . . . . .	11-17
11.10	Checking the card status (Read System Status) . . . . .	11-17
11.11	Inhibiting a channel (Channel Inhibits) . . . . .	11-18

## Part IV: Configuring AMC8 cards

<b>12</b>	<b>CONFIGURING INPUTS AND PROCESSING FUNCTIONS (AMC8).</b> . . . . .	<b>12-1</b>
12.1	Introduction . . . . .	12-1
12.2	Configuration of general parameters at card level . . . . .	12-2
12.2.1	General description . . . . .	12-2
12.2.2	Using remote channels . . . . .	12-3
12.3	Configuring single channels . . . . .	12-3
12.3.1	The input configuration tab . . . . .	12-4
12.3.2	The non-linear compensation tab . . . . .	12-9
12.3.3	The Processing & Alarms tab . . . . .	12-15
12.4	Configuring “multi-channels” . . . . .	12-18
12.4.1	The Processing tab . . . . .	12-18
12.4.2	The Alarms tab . . . . .	12-20
12.5	Copying card configurations . . . . .	12-21
<b>13</b>	<b>DEFINING LOGICAL COMBINATIONS OF ALARMS (AMC8)</b> . . . . .	<b>13-1</b>
13.1	Introduction . . . . .	13-1
13.2	Defining a basic alarm function . . . . .	13-2
13.3	Defining an advanced alarm function . . . . .	13-3
<b>14</b>	<b>OUTPUT MAPPING (AMC8)</b> . . . . .	<b>14-1</b>
14.1	Introduction . . . . .	14-1
14.2	Mapping alarms (discrete outputs) . . . . .	14-1
14.3	Configuring DC outputs (analog outputs) . . . . .	14-4
<b>15</b>	<b>COMMUNICATIONS MENU (AMC8).</b> . . . . .	<b>15-1</b>
15.1	Introduction . . . . .	15-1
15.2	Communication with a stand-alone rack (no CPUM present) . . . . .	15-2
15.3	Communication with a networked rack (CPUM present) . . . . .	15-2
15.4	Downloading the configuration (Send Configuration) . . . . .	15-2
15.5	Reading the configuration (Read Configuration) . . . . .	15-3
15.6	Testing the communications link (Read System Identification) . . . . .	15-3

15.7	The status latch (clearing and reading) . . . . .	15-4
15.8	The AMC outputs window (Read Outputs) . . . . .	15-7
15.8.1	Explanation of fields . . . . .	15-8
15.9	Resetting alarms (Alarm Reset) . . . . .	15-12
15.10	Checking LEDs on the AMC8 front panel (Lamp Test) . . . . .	15-12
15.11	Checking the card status (Read System Status) . . . . .	15-12
15.12	Inhibiting a channel (Channel Inhibits) . . . . .	15-13

## Part V: Configuring the system at rack level

<b>16</b>	<b>CONFIGURATION WINDOWS AT RACK LEVEL . . . . .</b>	<b>16-1</b>
16.1	Introduction . . . . .	16-1
16.2	The general information tab . . . . .	16-2
16.3	The backplane bus view tab . . . . .	16-3
16.3.1	The Tacho Bus branch . . . . .	16-4
16.3.2	The OC Bus branch . . . . .	16-6
16.3.3	The Raw Bus branch . . . . .	16-11
16.4	The backplane configuration tab . . . . .	16-13
16.4.1	The Tacho Bus branch . . . . .	16-13
16.4.2	The OC Bus branch . . . . .	16-13
16.4.3	The discrete information / Raw Bus branch . . . . .	16-14
16.4.4	The raw signals / Raw Bus branch . . . . .	16-16
16.5	IOC jumper matrix and RLC jumper matrix tabs . . . . .	16-17
16.5.1	Using the shortcut menu . . . . .	16-17
16.5.2	Jumper information (Relay Map Summary) . . . . .	16-21
<b>17</b>	<b>CUSTOMER SUPPORT . . . . .</b>	<b>17-1</b>
17.1	Contacting us . . . . .	17-1
17.2	Technical support . . . . .	17-1
17.3	Sales and repairs support . . . . .	17-1
17.4	Customer feedback . . . . .	17-2

## FAILURE REPORT FORM

## CUSTOMER FEEDBACK FORM

# Part I: Overview

**THIS PAGE INTENTIONALLY LEFT BLANK**

# 1 INTRODUCTION

## 1.1 What is MPS1?

MPS1 is a configuration software package for VM600 machinery protection systems, from Meggitt Sensing Systems' Vibro-Meter® product line.

## 1.2 Offline help

The VM600 MPSx software (MPS1) includes offline help that is installed locally on the computer. This help provides text that relate to windows within the software. You can obtain a help topic window by clicking the **Help** button on the splash screen, as shown in Figure 1-1, or by pressing the **F1** key at any time while using the software.



Figure 1-1: Help button on the splash screen

Choose the **Show Index** button on the Help Topic window to obtain a list of topics (the Help Index window appears).

You can also access the Help Index window by choosing Contents from the **Help** drop-down menu, as shown in Figure 1-2.



Figure 1-2: Help drop-down menu

## 1.3 Tool tips

The software also includes tool tips which help the user when entering values in some fields. If the user enters an invalid value in a field, a tool tip appears giving the range of accepted values.

## 1.4 Basic operating principle of the MPC4 card

The MPC4 card can simultaneously process signals connected to the following input channels:

- Two speed (tachometer or tacho) inputs  
The user can configure Alert+ and Alert- thresholds for these inputs.
- Four measurement inputs (for measuring vibration, dynamic pressure and so on)  
The user can configure Danger+, Alert+, Alert- and Danger- thresholds for these inputs.

As well as the input channels, the MPC4 also contains “processing channels” (see Figure 1-3):

- There are four single processing channels labelled Channel 1, Channel 2, Channel 3, and Channel 4, each providing two outputs labelled Output 1 and Output 2.
- There are two dual processing channels labelled Channels 1&2 and Channels 3&4, each providing one output.

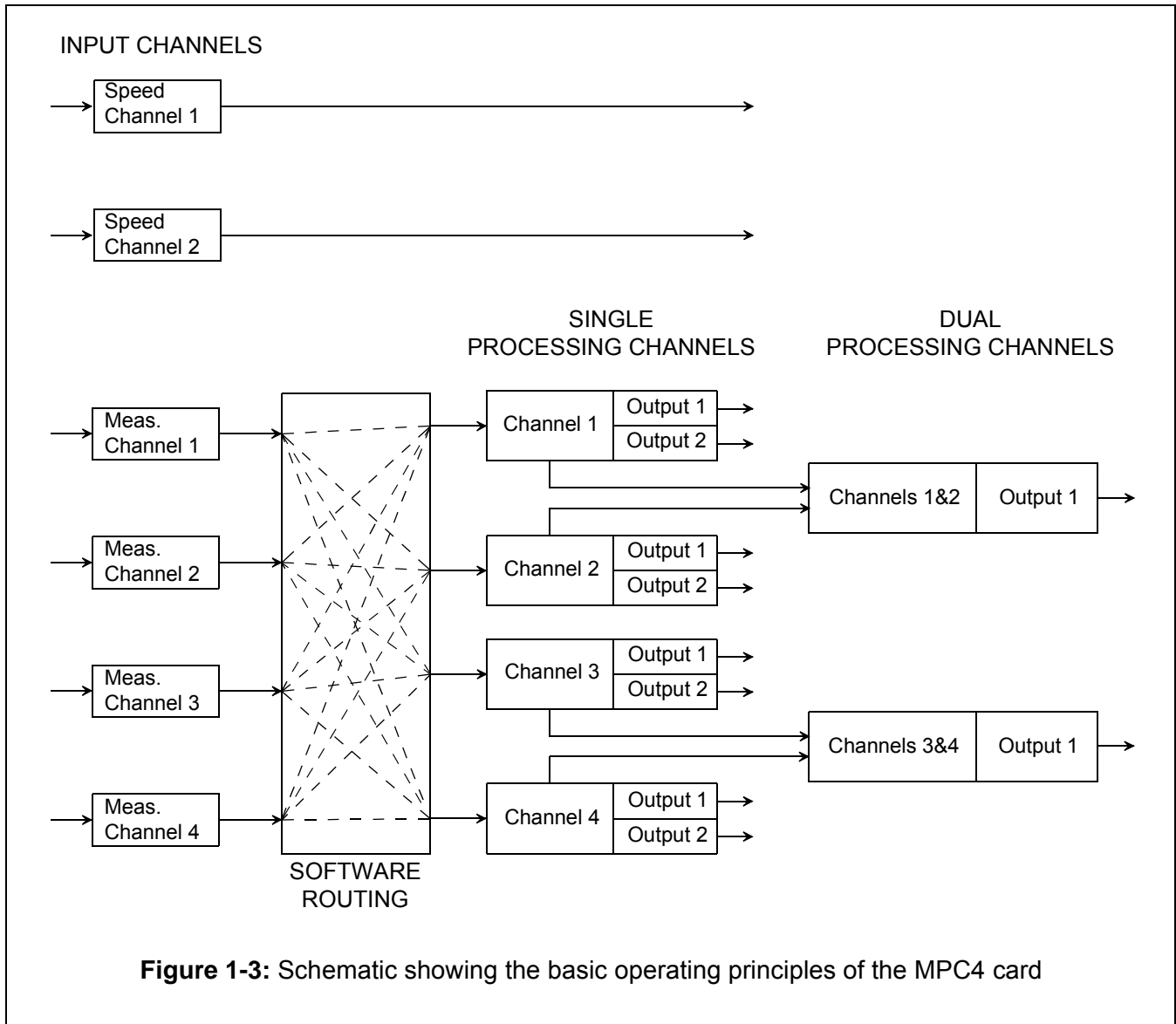

**Figure 1-3:** Schematic showing the basic operating principles of the MPC4 card

The flexibility of the VM600 MPS allows any measurement channel to be routed to any processing channel(s), that is, any signal routing combination is possible. However, it is recommended that the signals are routed as shown in Table 1-1.

**Table 1-1:** Recommended MPC4 card measurement channel and processing channel signal routing

Measurement channel	Processing channel
1	1
2	2
3	3
4	4

---

**NOTE:** Refer to the *VM600 Machinery Protection System (MPS)* hardware manual for further information.

---

## 1.5 Basic operating principle of the AMC8 card

The AMC8 card can simultaneously process signals connected to eight input channels. These can be used for:

- Measuring temperature with a thermocouple (TC) or resistance temperature detector (RTD) device.
- Measuring any other parameter (for example, flow rate, static pressure) from a system that provides a current-based (4 to 20 mA) or voltage-based (0 to 10 V) output.

Each of those eight input channels is routed to its corresponding “processing channel” (see Figure 1-4) These eight “single channels” are labelled Channel 1 to Channel 8 and each has a single output.

The software allows four additional “multi-channels” to be configured. These perform arithmetic operations on measurements made by any of the single processing channels. These channels are labelled Multi-Channel 1 to Multi-Channel 4 and each has a single output.

The user can configure Danger+, Alert+, Alert– and Danger– thresholds for any of the single channels or “multi-channels”.

Unlike the MPC4 card, the AMC8 card does not support flexible routing:

- Measurement Channel 1 is routed directly to Processing Channel 1
- Measurement Channel 2 is routed directly to Processing Channel 2
- And so on.

The only exception is that the software allows a “cold junction” temperature signal to be routed to another channel on the card.

---

**NOTE:** Refer to the *VM600 Machinery Protection System (MPS)* hardware manual for further information.

---

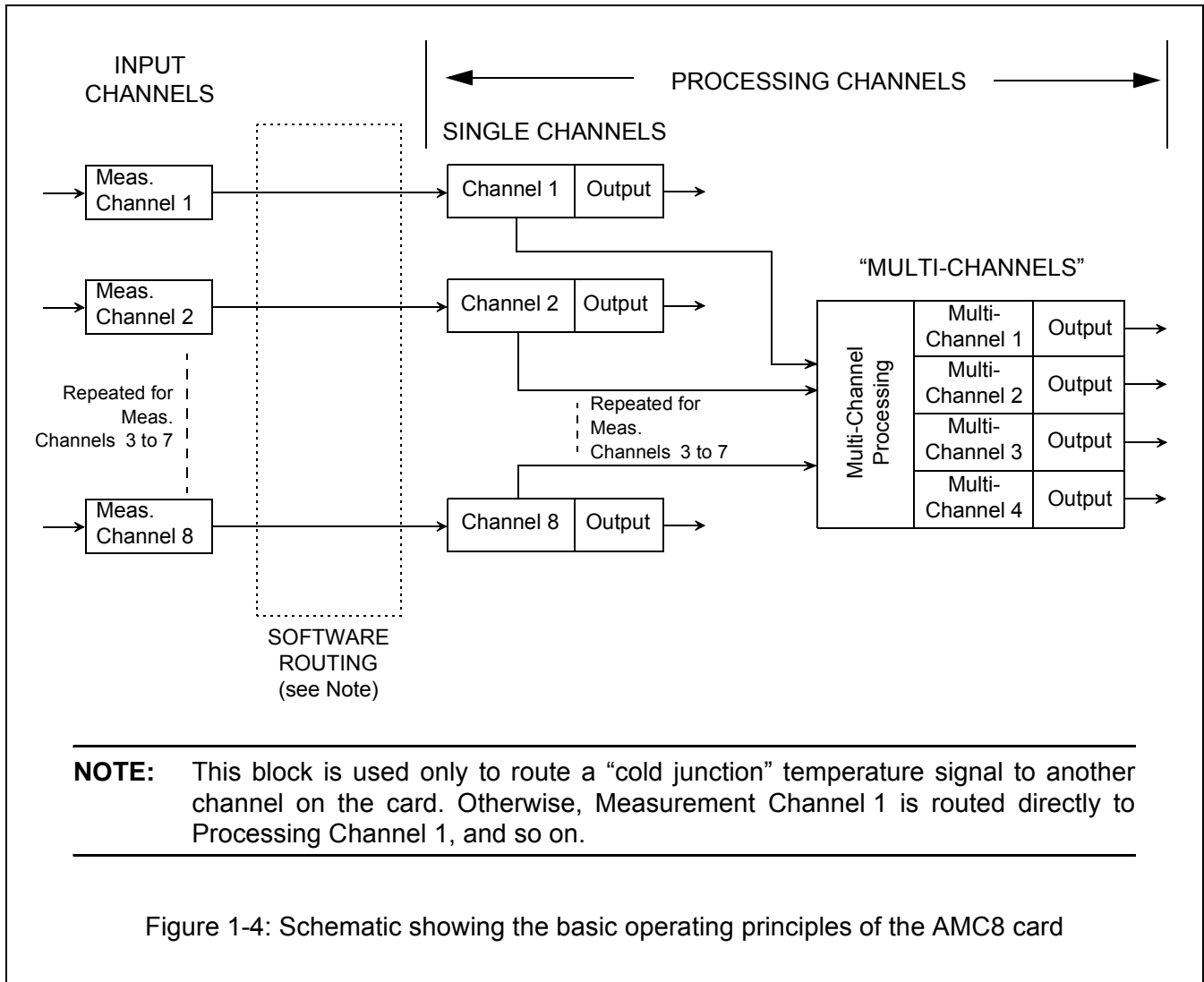

## 2 OVERVIEW OF SYSTEM CONFIGURATION

### 2.1 Introduction

This section provides an overview of the steps needed to set up a VM600 machinery protection system using the VM600 MPS1 software. Further information can be obtained from the detailed descriptions later in this manual.

### 2.2 VM600 MPS configuration

Before configuring individual cards, the user must first define the overall structure of the machinery protection system. This provides an outline of the system ("skeleton") to work on.

The VM600 MPS1 software uses the following configuration tree structure and hierarchy:

- Database 1
  - Rack 1
    - Card 1
    - Card 2
    - . . . .
    - Card q
  - Rack 2
    - Card 1
    - Card 2
    - . . . .
    - Card r
  - . . . .
  - Rack m
- Database 2
  - Rack 1
  - Rack 2
  - . . . .
  - Rack p
- . . . .
- Database n

The number of databases employed for the entire site must be evaluated and then these databases must be created. The VM600 racks used in the protection system must then be attributed to a particular database. Finally, the cards (MPC4, MPC4 SIL and/or AMC8) used in each rack must be defined, along with the rack slot (position) that they occupy.

Once this has been done, a tree structure is available on the main window of the VM600 MPS1 Configuration Editor (VM600 MPSx software) to allow the configuration of individual cards. The branches of the tree, with their various nodes, are shown for the MPC4 card in

Figure 2-1, for the MPC4 SIL card in Figure 2-2 and for the AMC8 card in Figure 2-3. See 5 Creating the configuration tree for further information.

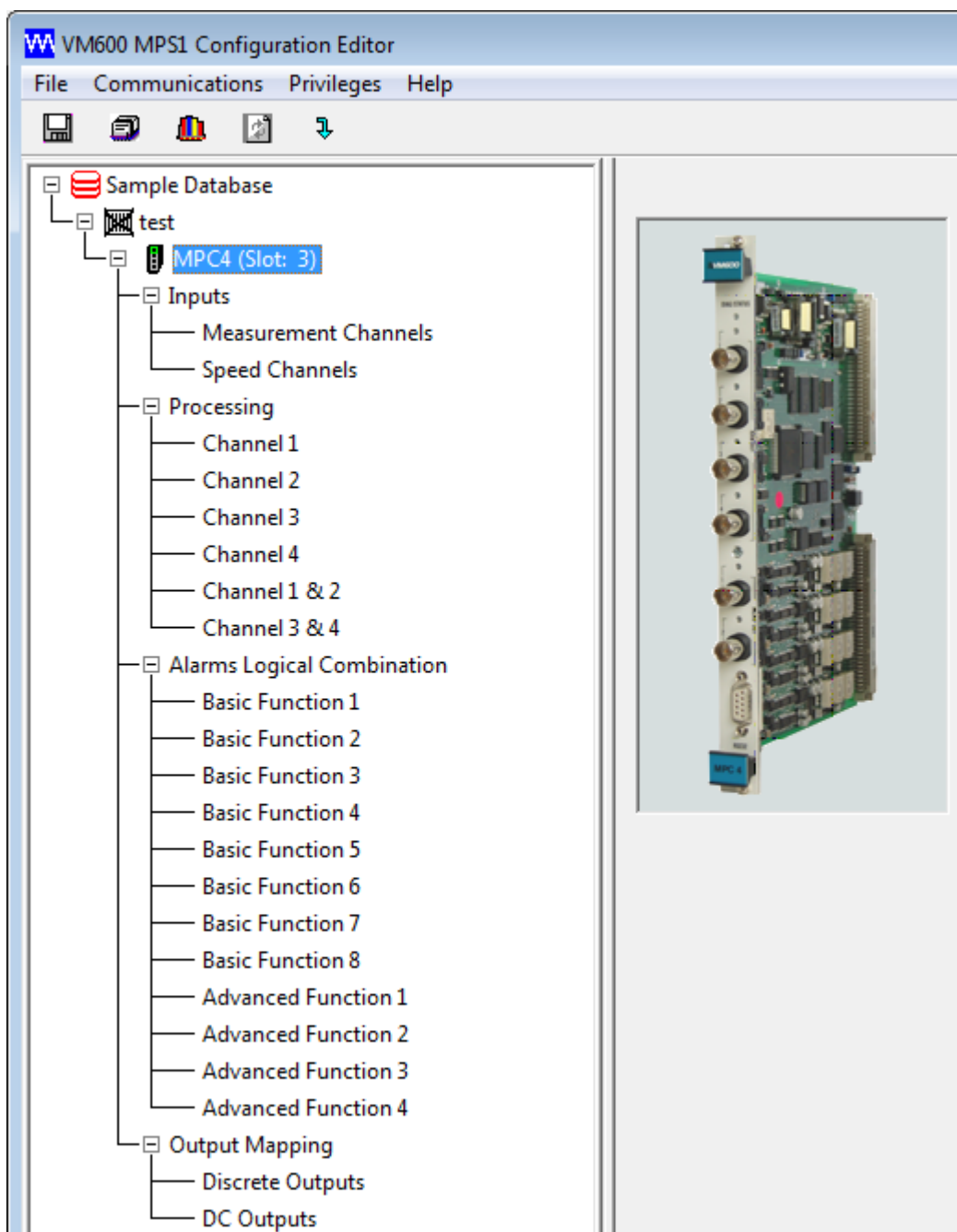

Figure 2-1: Branches of the tree structure for configuring an MPC4 card

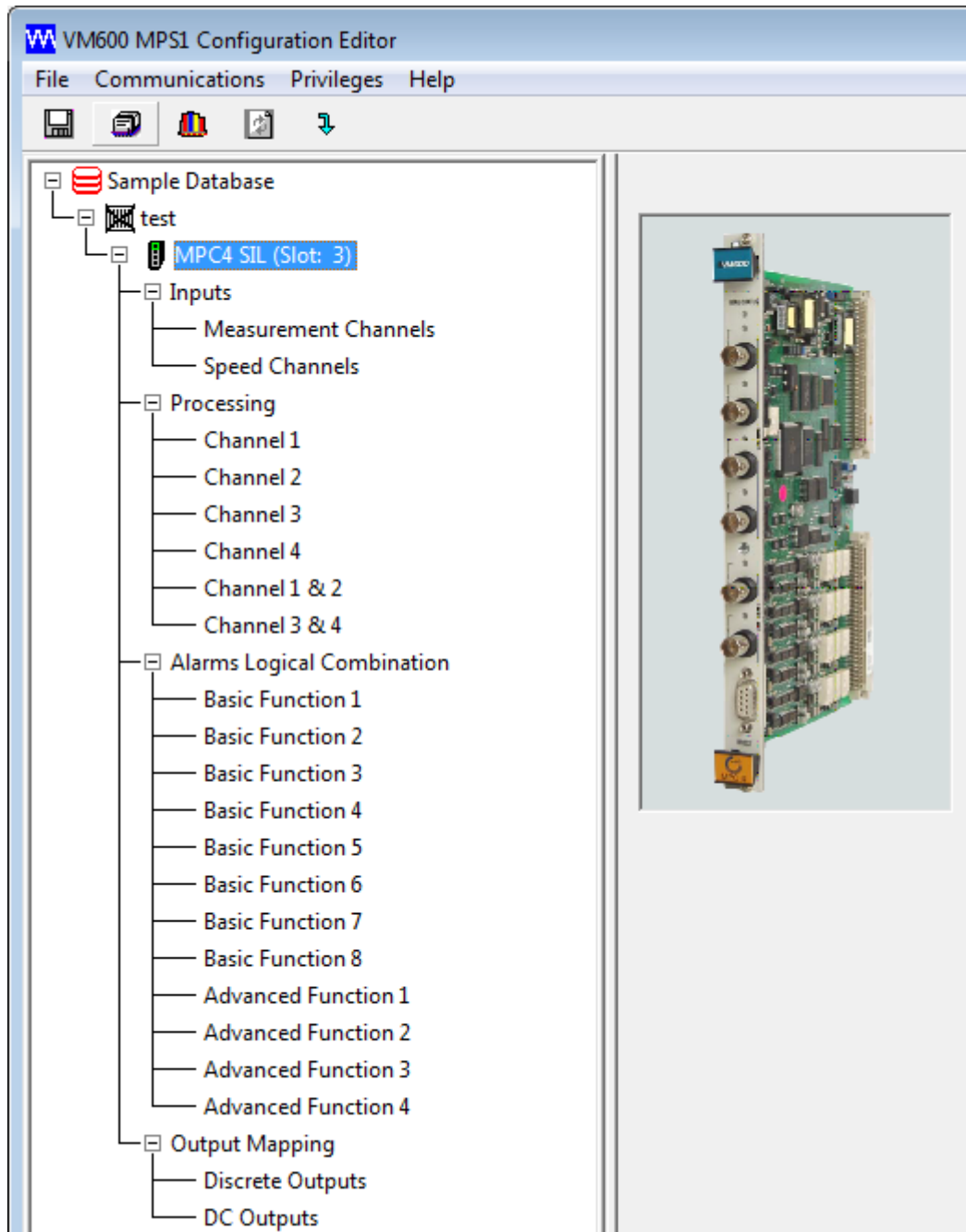

Figure 2-2: Branches of the tree structure for configuring an MPC4 SIL card

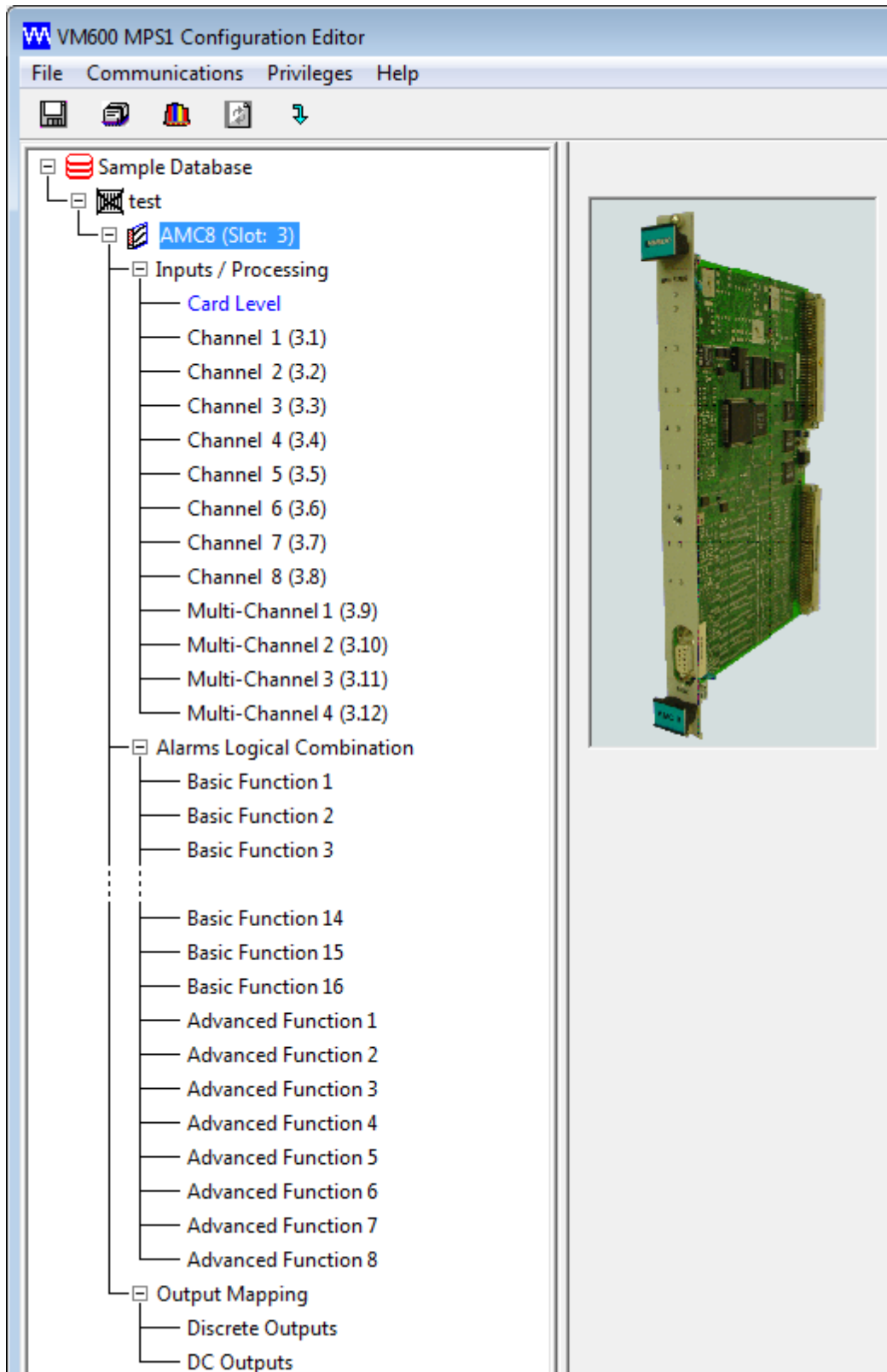

Figure 2-3: Branches of the tree structure for configuring an AMC8 card

As shown in Figure 2-3, Figure 2-1 and Figure 2-2, the image of the card displayed in the VM600 MPS1 Configuration Editor main window (card overview page) of the VM600 MPSx software corresponds to the type of card (MPC4, MPC4 SIL card or AMC8) in the tree structure. The image is different for MPC4 and MPC4 SIL cards.

## 2.3 Configuring individual cards

Once the overall structure ("skeleton") of the machinery protection system has been created, the installation of the protection system can be completed by configuring each individual card (MPC4, MPC4 SIL and/or AMC8) according to the procedures below.

### 2.3.1 Configuring MPC4 and MPC4 SIL cards

---

**NOTE:** The MPC4 machinery protection card is available in different versions, including standard and separate circuits versions that are both referred to as **MPC4** in the VM600 MPSx software, and a safety (SIL) version that is referred to as **MPC4 SIL** in the VM600 MPSx software.

---

**1-** Configure the input channels.

This operation is done from the Inputs branch of the tree structure (see Figure 2-1, Figure 2-2 and Figure 2-3). This allows parameters concerning the measurement sensors and speed sensors to be configured. These parameters include the sensor type and tag, the sensitivity, the dynamic range and the required power supply.

See 7 Input configuration (MPC4 and MPC4 SIL) for further information.

**2-** Define the type of processing to be performed on each channel.

This operation is done from the Processing branch of the tree structure. This allows each processing channel to be assigned to specific input sensors (providing signals representing, for example, vibration, dynamic pressure and speed).

All aspects of the signal processing are defined here, including the processing function (for example, Broad Band Absolute Bearing Vibration or Relative Shaft Vibration), filtering characteristics and measurement units.

Sub-windows allow alarm levels to be configured for each channel. Configurable parameters include hysteresis, delay time and latching.

See 8 Processing configuration (MPC4 and MPC4 SIL) for further information.

**3-** Define logical combinations of individual alarms.

This operation is optional. If required, it is done from the Alarms Logical Combination branch of the tree structure.

See 9 Defining logical combinations of alarms (MPC4 and MPC4 SIL) for further information.

**4-** Configure the output mapping parameters (attribution of relays and so on).

This operation is done from the Output Mapping branch of the tree structure.

The Discrete Outputs sub-branch allows global and individual alarms (generated by a speed input, a signal level or a hardware or software error) to be attributed to specific relays on the IOC and RLC cards.

The DC Outputs sub-branch allows DC outputs on the IOC card to be configured.

See 10 Output mapping (MPC4 and MPC4 SIL) for further information.

**5-** Download the configuration to the MPC4 card.

This operation is done from the **Communications** drop-down menu of the main window (VM600 MPS1 Configuration Editor).

This menu allows a configuration to be sent to a specific MPC4 card, or to the whole rack, via a network connection.

Once the protection system is running, information on measured signal levels and alarms for each channel, as well as the hardware and software status, may also be read using this menu.

Several windows may be opened at the same time to obtain information from several MPC4 cards simultaneously.

**6-** Save the configuration to disk for future use.

This operation is done from the **File** drop-down menu of the main window (VM600 MPS1 Configuration Editor).

In addition, see 6 Main window menus and commands, 6.3.3 Sending a configuration to a VM600 rack or card and 11 Communications menu (MPC4 and MPC4 SIL) for further information.

**2.3.1.1 Safety (SIL) version of the MPC4**

---

**NOTE:** The MPC4 machinery protection card is available in different versions, including a standard version, a separate circuits version and a safety (SIL) version. The MPC4 SIL (safety MPC4 card) does not have a VME bus interface and does not provide all of the signal processing capabilities of the standard and the separate circuits versions of the MPC4. Refer to the *MPC4 machinery protection card* data sheet and the *VM600 Machinery Protection System (MPS)* hardware manual for further information.

---



---

**NOTE:** Starting with VM600 MPSx software version 2.6, the VM600 MPSx software makes a distinction between safety MPC4 cards and other MPC4 cards by referring to the standard version and the separate circuits version of the MPC4 card as an **MPC4** and referring to the safety version of the MPC4 card as an **MPC4 SIL**.

---

Starting with VM600 MPSx software version 2.6, when an MPC4 card is being configured, the MPS1 and MPS2 software will automatically:

- Communicate with the MPC4 card in order to identify its version: 'standard' or 'separate circuits' (**MPC4**), or 'safety' (**MPC4 SIL**).
- Check the configuration in the VM600 MPSx software in order to ensure that it is compatible with the version of MPC4 card detected (**MPC4** or **MPC4 SIL**):
  - If the configuration is compatible with the MPC4 card, then the VM600 MPS software will download the configuration to the card. That is, the software will send an MPC4 card configuration to an **MPC4** card and it will send an MPC4 SIL card configuration to an **MPC4 SIL** card.
  - If the configuration is not compatible with the MPC4 card, then the VM600 MPS software displays a message informing the user of the incompatibility and will not download the configuration to the card. That is, the software will not send an MPC4 card configuration to an **MPC4 SIL** card and it will not send an MPC4 SIL card configuration to an **MPC4** card.

For example, in this way, a 'safety' MPC4 card cannot be configured with Narrow Band (Tracking) Vibration or other non-supported processing functions.

### 2.3.2 Configuring AMC8 cards

- 1- Configure the input channels, define the processing functions and set up alarm levels  
These operations are done from the Inputs/Processing branch of the tree structure (see Figure 2-3). Various tabs can be called up.  
One tab allows input parameters concerning the measurement sensors to be configured/defined (for example, sensor type and tag, sensor output characteristics and OK Level thresholds).  
Other tabs allow various processing functions and alarm levels to be configured for each channel. Configurable parameters include hysteresis, delay time and latching.  
The four "multi-channels" can also be defined from the Inputs/Processing branch of the tree structure, if required.  
See 12 Configuring inputs and processing functions (AMC8) for further information.
- 2- Define logical combinations of individual alarms.  
This operation is optional. If required, it is done from the Alarms Logical Combination branch of the tree structure.  
See 13 Defining logical combinations of alarms (AMC8) for further information.
- 3- Configure the output mapping parameters (attribution of relays and so on).  
This operation is done from the Output Mapping branch of the tree structure.  
The Discrete Outputs sub-branch allows global and individual alarms (generated by a signal level or a hardware or software error) to be attributed to specific relays on the IOC and RLC cards.  
The DC Outputs sub-branch allows DC outputs on the IOC card to be configured.  
See 14 Output mapping (AMC8) for further information.
- 4- Download the configuration to the AMC8 card.  
This operation is done from the **Communications** drop-down menu of the main window (VM600 MPS1 Configuration Editor).  
This menu allows a configuration to be sent to a specific AMC8 card, or to the whole rack, via a network connection.  
Once the protection system is running, information on measured signal levels and alarms for each channel, as well as the hardware and software status, may also be read using this menu. Several windows may be opened at the same time to obtain information from several AMC8 cards simultaneously.
- 5- Save the configuration to disk for future use.  
This operation is done from the **File** drop-down menu of the main window (VM600 MPS1 Configuration Editor).

In addition, see 6 Main window menus and commands, 6.3.3 Sending a configuration to a VM600 rack or card and 15 Communications menu (AMC8) for further information.

## 2.4 Configuring the rack

Once all cards (MPC4, MPC4 SIL and/or AMC8) have been configured, it is usually necessary to perform additional configuration at rack level. This is to ensure that signals are properly routed over the buses on the rack backplane and that signal conflicts are avoided.

See 16 Configuration windows at rack level for further information.

# **Part II: Installation and general configuration**

**THIS PAGE INTENTIONALLY LEFT BLANK**

## 3 INSTALLING THE SOFTWARE

### 3.1 Before starting

#### 3.1.1 Items delivered

For first-time installation, you should have received the following items:

- One CD containing:
  - VM600 MPS1 Configuration Software
  - An electronic version of the software manual (.pdf file):  
*VM600 MPS1 Configuration Software for Machinery Protection Systems*  
(MSS document ref. MAMPS1-SW/E).
  - Release and Installation Notes (.doc file)
- One paper copy of the software manual:  
*VM600 MPS1 Configuration Software for Machinery Protection Systems*  
(MSS document ref. MAMPS1-SW/E)
- One RS-232 communication cable.

For a software update, you receive only the following item:

- One CD containing:
  - VM600 MPS1 Configuration Software
  - An electronic version of the software manual (.pdf file):  
*VM600 MPS1 Configuration Software for Machinery Protection Systems*  
(MSS document ref. MAMPS1-SW/E)
  - Release and Installation Notes (.pdf file).

---

**NOTE:** All original CDs should be stored in a safe place once the software installation has been performed.

---

#### 3.1.2 System requirements

The VM600 MPS1 software may be installed on most modern personal computers or laptops. The following minimum computer configuration is required to run the software:

- Microsoft® Windows® Server 2003, Windows NT, Windows 2000, Windows XP, Windows Vista or Windows 7 operating system
- 200 MHz 32-bit (x86) processor or equivalent
- 32 MB system memory (RAM)
- At least 200 MB of hard disk space
- 16-colour VGA display
- One 9-pin serial port (RS-232)
- Ethernet or Fast Ethernet network card (TCP/IP)
- CD/DVD drive
- Optional 100 GB (or larger) backup media.

## 3.2 Installation procedure

---

**NOTE:** Save your work and exit (close) all applications before beginning the installation.

---

The procedure below is valid for first-time installation of the VM600 MPSx software as well as for subsequent installation of software releases.

---

**NOTE:** It is essential that you remove any previous versions of the software before installing the new version. See 3.3 Removing an old version of the software. Removing a previous version of the software does not remove any user-defined databases.

---

- 1- Insert the CD containing the VM600 MPS1 software in the CD/DVD drive of your computer.  
The installation process should start automatically. If this is the case, the VM600 MPS1 InstallShield Wizard starts (the initial window of which is shown in Figure 3-1). Go to step 5.  
If the process does not start automatically, go to step 2.
- 2- Choose **Start > Run** from the Windows task bar.
- 3- Use the Browse function to find the executable file `setup.exe` in the root directory of the CD.
- 4- Double-click the `setup.exe` file to start the VM600 MPS1 InstallShield Wizard (see Figure 3-1).

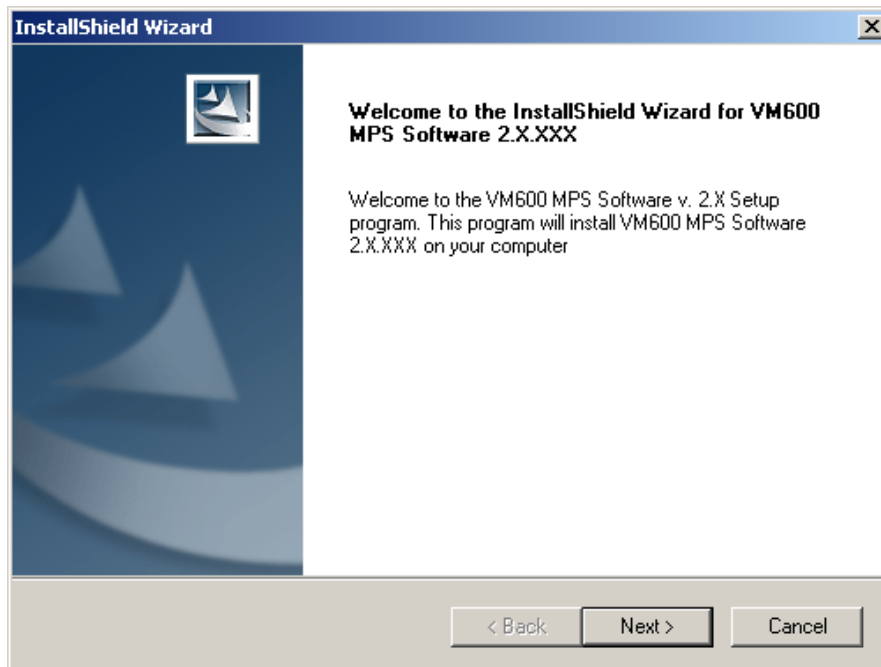

**Figure 3-1:** Welcome window of the VM600 MPS1 InstallShield Wizard

- 5- Follow the instructions given by the wizard to install the software.  
As part of the installation process, the wizard displays a Customer Information window that, among other information, asks you to enter the Serial Number of your software.

If you accept the default Serial Number (BASIC MPS), the VM600 MPSx software licence is not validated and a demonstration version of the software will be installed (see Figure 3-2). This may consist of a limited set of features.

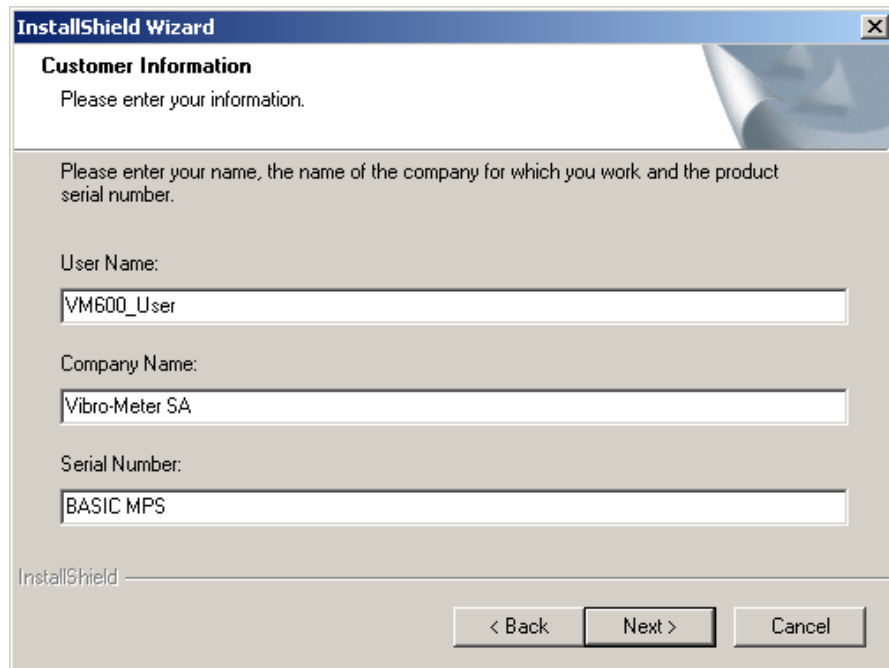

The screenshot shows the 'InstallShield Wizard' window with the 'Customer Information' tab selected. The window contains the following text and input fields:

- Title bar: InstallShield Wizard
- Section header: Customer Information
- Instruction: Please enter your information.
- Text: Please enter your name, the name of the company for which you work and the product serial number.
- User Name: VM600\_User
- Company Name: Vibro-Meter SA
- Serial Number: BASIC MPS
- Footer: InstallShield
- Buttons: < Back, Next >, Cancel

**Figure 3-2:** Customer Information window showing the default Serial Number

The CD Key, which is found on the back of the product CD case, must be entered as the Serial Number (see Figure 3-3). This is necessary to validate the VM600 MPSx software licence.

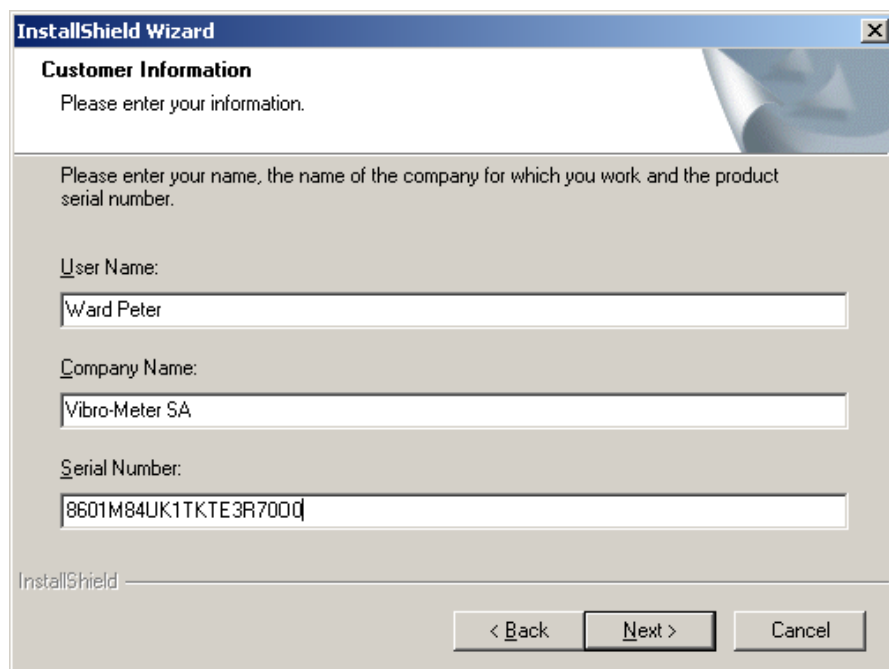

The screenshot shows the 'InstallShield Wizard' window with the 'Customer Information' tab selected. The window contains the following text and input fields:

- Title bar: InstallShield Wizard
- Section header: Customer Information
- Instruction: Please enter your information.
- Text: Please enter your name, the name of the company for which you work and the product serial number.
- User Name: Ward Peter
- Company Name: Vibro-Meter SA
- Serial Number: 8601M84UK1TKTE3R700Q
- Footer: InstallShield
- Buttons: < Back, Next >, Cancel

**Figure 3-3:** Customer Information window showing an example valid Serial Number (CD Key)

- 6- Define the location where the software is to be installed on the hard disk. The following default destination folder is proposed:

C:\Program Files\VM600\_MPS

An alternative folder can be chosen if desired.

---

**NOTE:** The default location for the Windows Program Files folder depends on the operating system installed on the computer:

C:\Program Files on 32-bit versions of Windows, but

C:\Program Files (x86) on 64-bit versions of Windows.

---

A VM600 MPS1 icon  (shortcut) appears on the Windows desktop when the installation is complete.

### 3.3 Removing an old version of the software

---

**NOTE:** Save your work and exit (close) all applications before removing an old version of the software.

---

#### 3.3.1 Precautions concerning databases

---

**NOTE:** Removing a previous version of the software does not remove any user-defined databases.

However, as an extra precaution, it is recommended to make a backup copy of your database(s) before removing any software.

This copy can later be removed after checking that the software upgrade has been performed correctly.

---

Data is stored in database directories having a .db file name extension. Unless an alternative destination folder was chosen, these directories are found in the following default folder:

C:\Program Files\VM600\_MPS

---

**NOTE:** The default location for the Windows Program Files folder depends on the operating system installed on the computer:

C:\Program Files on 32-bit versions of Windows, but

C:\Program Files (x86) on 64-bit versions of Windows.

---

You should make a (temporary) copy of these database directories elsewhere on your computer. Do not put them under C:\Program Files\VM600\_MPS.

#### 3.3.2 Removing the software

Use the procedure below to remove an old version of the software before installing a newer version:

- 1- Choose **Add or Remove Programs** from the Windows **Control Panel**.
- 2- Select **Change or Remove Programs**.
- 3- Highlight the application (VM600 MPS software) and click the **Remove** button.

## 4 GETTING STARTED

### 4.1 Starting the VM600 MPS1 software

To start the VM600 MPS1 software:

- 1- Double-click the MPS1 icon  on your desktop.

This icon was created during the installation of the software. If for some reason it does not appear on the desktop, click **Start > Programs > VM600 MPS Software > MPS1**, or navigate to the **VM600\_MPS\Bin** directory on the computer's hard disk and double-click the `mps1.exe` file.

The VM600 MPS1 splash screen (window) appears, as shown in Figure 4-1.

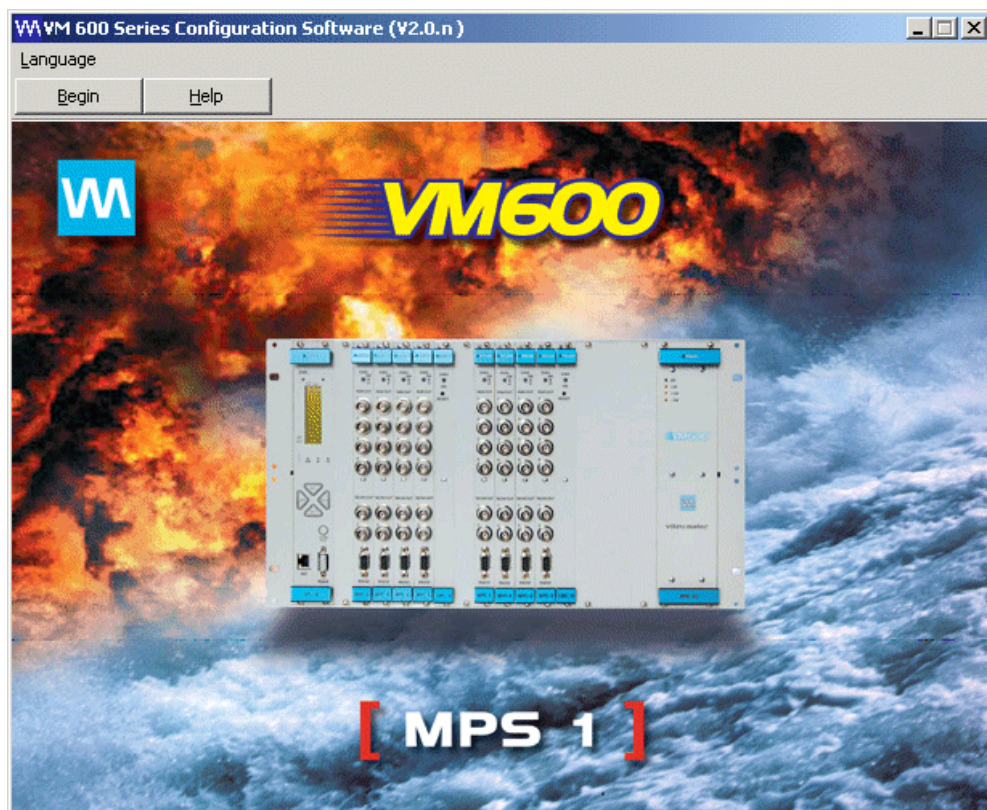

Figure 4-1: VM600 MPS1 splash screen

- 2- Choose the working language from the drop-down menu in the top, left-hand corner of the window, as shown in Figure 4-2. The selected language is used by default the next time the VM600 MPS1 software is started.

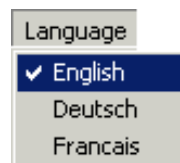

Figure 4-2: Language drop-down menu

- 3- Click the **Begin** button, which is found below the **Language** menu.
- 4- The first time that the VM600 MPSx software is run, a following dialog box similar to the following appears:

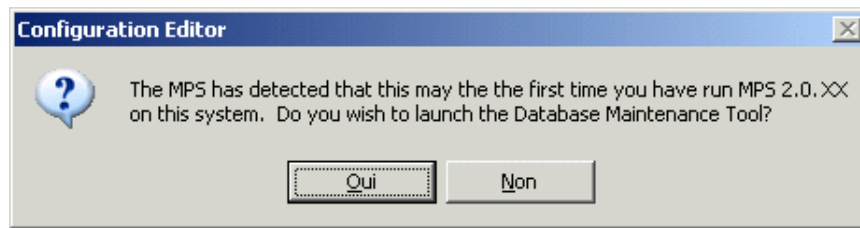

Figure 4-3: Database Maintenance Tool prompt

Click **Yes** to launch the Database Maintenance Tool (see 6.2.3 Using the Database Manager for details). Otherwise, click **No** to continue.

- 5- The main VM600 MPS1 Configuration Editor window appears, as shown in Figure 4-4.

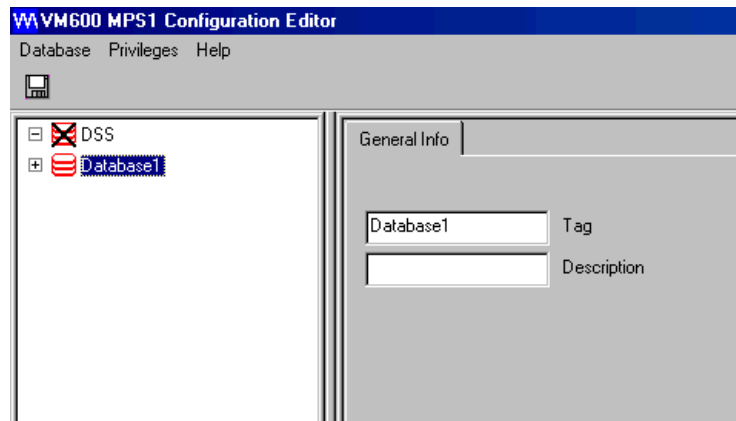

Figure 4-4: Main window of the VM600 MPS1 Configuration Editor (VM600 MPSx software)

## 4.2 VM600 MPSx software privilege levels

As shown in Figure 4-5, the VM600 MPSx software implements a system of privileges (user access rights) to control and limit the functionality of the software available to different levels of user.

The VM600 MPSx software has four levels of privilege: Read, User, Master and Super. The User, Master and Super levels are password protected in order to help prevent accidental changes or unauthorised access to the configuration of a VM600 MPS.

---

**NOTE:** The passwords for the VM600 MPSx software privilege levels are stored on the computer running the VM600 MPSx software.

---

In addition to the VM600 MPSx software's system of privileges, a VM600 MPS containing a CPUM card can implement additional rack security features (see 4.3 VM600 MPS rack (CPUM) security).

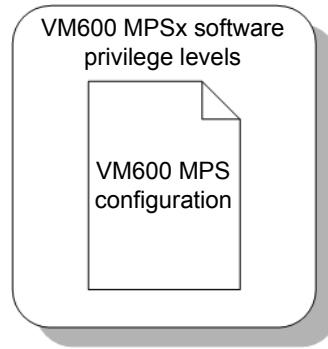

**Figure 4-5:** VM600 MPSx software privilege levels

### 4.2.1 Selecting the privilege level

The VM600 MPSx software has four levels of privileges:

#### 1- Read

This read-only level provides the lowest level of privileges and the highest level of protection. It is the default level granted when the VM600 MPSx software is started and no password is required for access.

With Read-level privileges, configuration information can be read but it cannot be changed. This information includes outputs, system status, system identification and status latch data.

#### 2- User

This provides more privileges than the Read level. In addition to the information available at the Read-level, files can be uploaded to a VM600 rack.

#### 3- Master

This provides more privileges than the User level. In addition to the information and operations available at the User level, alarm levels and attributes can be changed.

#### 4- Super

This provides the highest level of privileges (that is, full access rights) and the lowest level of protection.

With Super-level privileges, the current configuration can be modified and any changes can be saved.

---

**NOTE:** At Read, User and Master levels, certain menu commands are unavailable (greyed out) and therefore cannot be run.

---

User, Master and Super levels can be protected with passwords. See 4.2.2 Changing privilege-level passwords and 4.2.3 Defining privilege-level passwords during the initial installation for further information.

The **Privileges** drop-down menu at the top of the main VM600 MPSx Configuration Editor window (see Figure 4-6) is used to select the desired privilege level. Enter the appropriate password in the dialog box that appears (see Figure 4-7, which shows an example for the Master level).

---

**NOTE:** All passwords are case-sensitive. For example, “user”, “User” and “USER” are treated as three different passwords.

---

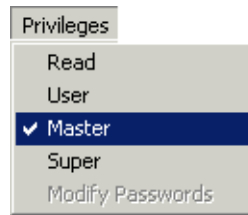

**Figure 4-6:** Privileges drop-down menu

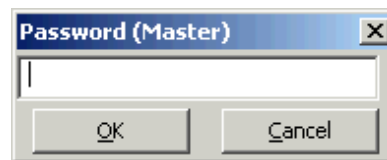

**Figure 4-7:** Dialog box to enter the Master password

The current privilege level is displayed at the bottom of the VM600 MPS1 Configuration Editor window, as shown in Figure 4-8.

---

**NOTE:** At User, Master and Super levels, the VM600 MPSx software reverts to Read level if you do not touch the keyboard or mouse for a period of 30 minutes.

---

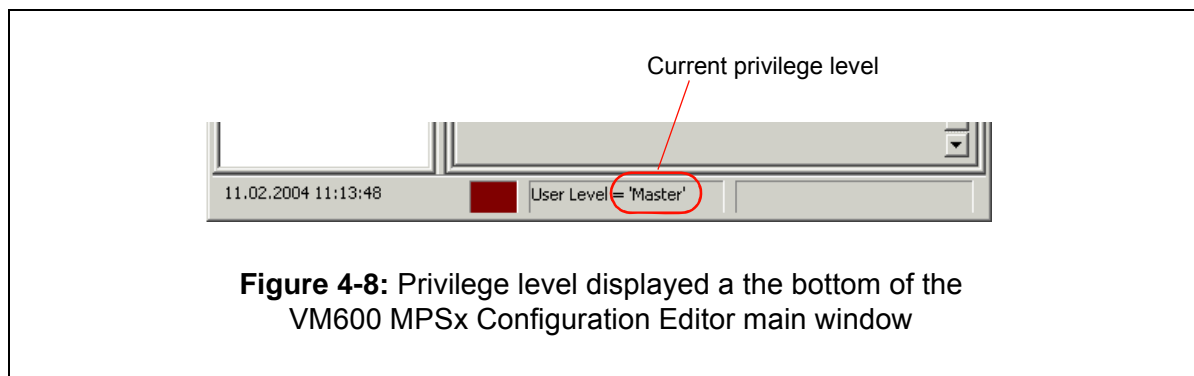

**Figure 4-8:** Privilege level displayed at the bottom of the VM600 MPSx Configuration Editor main window

#### 4.2.2 Changing privilege-level passwords

---

**NOTE:** Super-level privileges are required in order to be able to change passwords.

---

To change a privilege-level password:

- 1- Select **Modify Passwords** from the **Privileges** drop-down menu.
- 2- Enter the existing Super level password in the dialog box (similar to Figure 4-7).

The Modify Passwords dialog box appears (see Figure 4-9). This allows passwords for User, Master and Super levels to be modified.

- 3- Type in the new password and type it in again in the **Confirm** field below.

**NOTE:** All passwords are case-sensitive. For example, “user”, “User” and “USER” are treated as three different passwords.

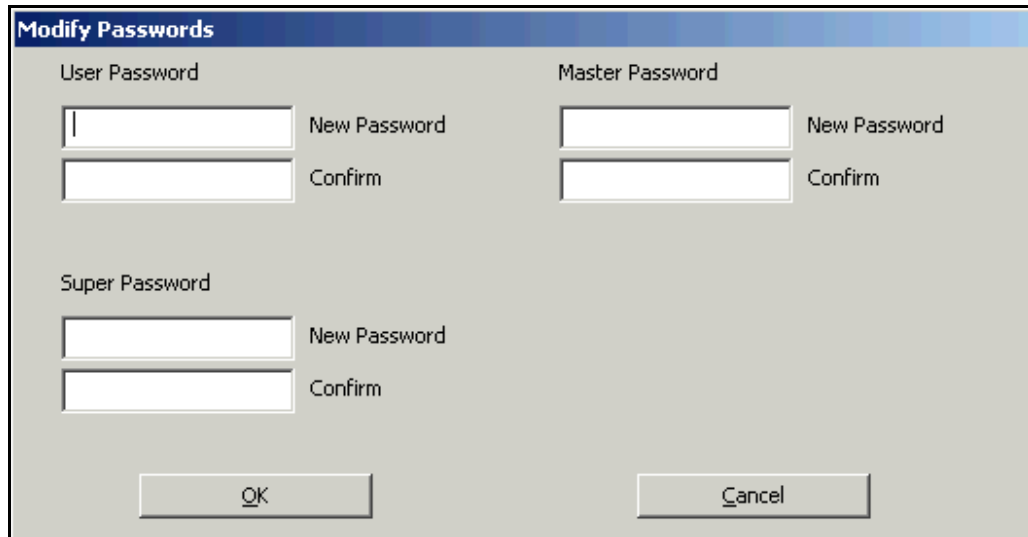

The image shows a dialog box titled "Modify Passwords". It is divided into three sections: "User Password", "Master Password", and "Super Password". Each section has two input fields: "New Password" and "Confirm". At the bottom of the dialog, there are two buttons: "OK" and "Cancel".

**Figure 4-9:** Modify Passwords dialog box

### 4.2.3 Defining privilege-level passwords during the initial installation

When the VM600 MPSx software is initially installed, the Super, Master and User passwords are *super*, *master* and *user*, respectively (all lower-case characters). The system administrator should redefine all three privilege-level passwords during the initial installation of the software, using the following procedure:

- 1- Choose **Super** from the **Privileges** drop-down menu.  
A dialog box asking for the Super password appears.
- 2- Type “super” (this is the default Super level password)
- 3- Choose **Modify Passwords** from the **Privileges** drop-down menu.  
The dialog box asking for the Super password appears again.
- 4- Type in “super” again  
The Modify Passwords dialog box appears (see Figure 4-9).
- 5- Type in a new Super level password, first in the **New Password** field and then in the **Confirm** field below.
- 6- Type in a new Master level password, first in the **New Password** field and then in the **Confirm** field below.
- 7- Type in a new User level password, first in the **New Password** field and then in the **Confirm** field below.
- 8- Click the **OK** button to validate the new passwords.

### 4.3 VM600 MPS rack (CPUM) security

As shown in Figure 4-10, a VM600 MPS in a 19" system rack (ABE04x) containing a CPUM card can implement specific rack security features in order to limit the functionality of the MPS that are available via the CPUM to Ethernet-based connections, such as the VM600 MPSx software, the CPUM Configurator software or a Modbus TCP connection.

---

**NOTE:** See 4.4 CPUM Configurator software for further information on the CPUM Configurator software.

---

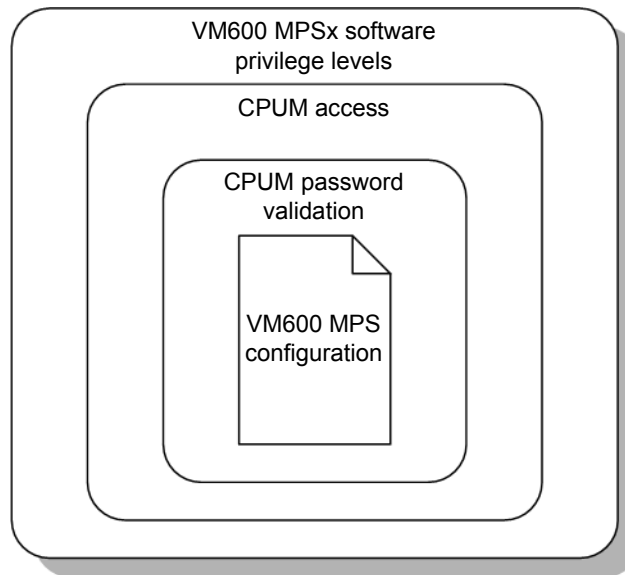

**Figure 4-10:** VM600 MPS rack (CPUM) security

The use of the CPUM security features is recommended in order to help prevent accidental or unauthorised access to a VM600 MPS configuration and other MPS system functionality, thereby reducing the possibility of interference in the operation of the MPS and the machinery being monitored.

---

**NOTE:** VM600 MPSx software version 2.7 or later and a networked VM600 rack containing a CPUM card running firmware version 077 or later are required in order to use VM600 MPS rack (CPUM) security.

---

By default, the CPUM security features are disabled in order to ensure backwards compatibility with CPUM cards running firmware version 076 or earlier.

---

**NOTE:** The passwords and settings for CPUM security are stored on the CPUM card.

---

The VM600 MPS rack (CPUM) security features are in addition to the VM600 MPSx software's system of privileges (see 4.2 VM600 MPSx software privilege levels).

For example, in a typical machinery monitoring application in a modern power-generating station, the VM600 MPS is installed close to the machinery being monitored, which is installed in the highest-security zone of the plant. Such security zones are usually restricted and protected areas with physical barriers, specific access requirements and surveillance equipment. Accordingly, only approved and cleared personnel have the physical access to a

VM600 MPS in a power station that is required in order to change the CPUM access setting (CPUM access lock), one of the new CPUM security features.

The CPUM access lock prevents remote access to a VM600 MPS, effectively acting as a hardware lock, and it is not possible to “unlock” a CPUM/VM600 remotely.

---

**NOTE:** As the CPUM access setting for a CPUM card is configured using the keys on the front panel of the card, physical access to the CPUM card (VM600 rack) is required.

---

### 4.3.1 Using CPUM security

VM600 MPS rack (CPUM) security consists of two levels of protection integrated in the CPUM card: CPUM access lock and MPS password validation.

**CPUM Access Lock** is a CPUM access setting that can be thought of as a “hardware” security feature that limits Ethernet-based connections to a VM600 MPS to “read only” operations.

- When CPUM access is blocked, the MPS operations that are available are limited to read only operations. That is, communications with the VM600 rack via Ethernet is read only, such that it is possible to read outputs from the MPS but it is not possible to change (commit) the configuration of a VM600 rack or to interfere in the operation of the MPS.
- When CPUM access is allowed, the MPS operations that are available depend on the MPS password validation (see **MPS Password Validation**).

Physical access to the VM600 rack is required in order to change the CPUM Access Lock.

**MPS Password Validation** can be thought of as a “software” security feature that limits Ethernet-based connections to a VM600 MPS to “read only” operations plus a permitted subset of “write” operations.

- When MPS password validation is enabled, the MPS operations that are available are limited to read only operations and certain specific write operations (“read + restricted write”), that is, write operations which require additional authentication before being run. For example, VM600 MPS commands such as alarm reset (AR) or changing a fieldbus configuration. While the read only operations run as usual, the write operations require that the correct CPUM password is entered by the user before they are run.
- When MPS password validation is disabled, all VM600 MPS operations are available.

The VM600 MPSx software and CPUM access (CPUM Access Lock: Unlocked) are required in order to change the MPS Password Validation.

Basically, the use of CPUM access lock protects the VM600 MPS configuration and prevents all sensitive VM600 MPS operations from being run (that is, “read only” – the highest level of security). Like CPUM access lock, the use of MPS password validation protects the configuration of the MPC4 cards and AMC8 cards in the VM600 rack but MPS password validation also allows certain VM600 MPS operations to be run (that is, “read + restricted write” – a reduced level of security). See the table on the following page for further information on the operations permitted when CPUM security features are used.

---

**NOTE:** The CPUM access lock is a stronger protection mechanism than MPS password validation and is used to implement the highest level of VM600 MPS rack security (that is, with the fewest VM600 MPS operations available to the user).

---

Table 4-1 shows the VM600 MPS operations affected by the CPUM security features.

**Table 4-1:** VM600 MPS operations affected by the CPUM security features

VM600 MPS operation (protected by CPUM security features)	CPUM security feature	
	CPUM Access Lock	MPS Password Validation
Committing a VM600 MPS configuration	Not available	Password protected
Running MPS commands via VM600 MPSx software: <ul style="list-style-type: none"> <li>Alarm reset (AR)</li> <li>Channel inhibit (sensor bypass)</li> <li>Danger bypass (DB)</li> <li>Trip multiply (TM)</li> <li>Clear status latch</li> </ul>	Not available	Password protected
Running MPS commands via Modbus: <ul style="list-style-type: none"> <li>Alarm reset (AR)</li> <li>Channel inhibit (sensor bypass)</li> <li>Danger bypass (DB)</li> <li>Trip multiply (TM)</li> <li>Clear status latch</li> </ul>	Not available	Available
Changing a VM600 MPS fieldbus configuration (such as Modbus)	Not available	Available
Accessing a CPUM using an Ethernet-based connection such as CPUM Configurator, FTP or Telnet	Not available	Available
Displaying VM600 MPS measurement outputs such as the outputs windows and plots (historical or live data)	Available	Available
Operation of a VM600 CMS condition monitoring system using cards such as the CMC16/IOC16T in the same VM600 rack	Available	Available
Operation of a VibroSight condition monitoring system using cards such as the XMx16/XIO16T in the same VM600 rack	Available	Available
MPS Password Validation security feature	Not available	Available
CPUM Access Lock security feature	Available	Available
Level of security	Highest	Reduced

**Notes**

When CPUM access is blocked (**CPUM Access Lock: Locked**), a VM600 MPS is limited to “read only” operations as shown in the **CPUM Access Lock** column above.

When CPUM access is allowed (**CPUM Access Lock: Unlocked**), MPS Password Validation can be enabled (**MPS Password Validation: Enabled**) and a VM600 MPS is limited to “read + restricted write” operations as shown in the **MPS Password Validation** column above. However, while the read only operations run as usual, the write operations require that the correct CPUM password is entered by the user before they are run.

When CPUM access is allowed (**CPUM Access Lock: Unlocked**) and MPS Password Validation is disabled (**MPS Password Validation: Disabled**), a VM600 MPS can perform all operations (“read + write”). With these settings, no VM600 MPS rack (CPUM) security is used, which is equivalent to using a VM600 system with VM600 MPSx software version 2.6 or earlier and CPUM firmware version 076 or earlier.

Table 4-2 shows the relationship between CPUM access lock, MPS password validation and access rights.

**Table 4-2:** Relationship between CPUM access lock, MPS password validation and access rights

CPUM Access Lock	MPS Password Validation	Access rights	Notes
Locked	---	Read only	Highest level of security
Unlocked	Enabled with password not entered correctly	Read only	Reduced level of security
Unlocked	Enabled with password entered correctly	Read + restricted write	
Unlocked	Disabled	Read + write	Lowest level of security. This is equivalent to using a VM600 system with VM600 MPSx software version 2.6 or earlier and CPUM firmware version 076 or earlier.

### 4.3.2 Displaying CPUM security settings

The VM600 MPSx software can be used to communicate with the CPUM card in order to read and display the current state of the CPUM security settings.

---

**NOTE:** The VM600 MPSx software privilege level must be Master or Super in order to access the **CPUM Security** command (see 4.2 VM600 MPSx software privilege levels).

---

To read the CPUM security settings:

- 1- Click on a rack level node in the configuration tree to select it, then use the **Communications > CPUM security** menu command.  
Alternatively, right-click on a rack level node in the configuration tree, then click **CPUM security**.
- 2- In the **CPUM Security** window that appears, under **Rack Selection**, in the **Hostname** field, enter either the IP address of the rack (CPUM card) in dot-decimal notation or a predefined host name. Then click the **Read Security Settings** button.

The **CPUM Security** window updates and displays, under **CPUM Security Settings**, the status of the CPUM access (**CPUM Access Lock**) and the status of the MPS password validation (**MPS Password Validation**).

The “session” information (**Session Information**) shows if the VM600 MPSx software is logged on to the CPUM card, which happens either automatically upon entering the correct CPUM password when running a VM600 MPS command or manually by using the **Log On To CPUM card** button.

---

**NOTE:** The fields under **CPUM Security Settings** are unavailable (greyed out) until the **Read Security Settings** button is used to establish communications with the CPUM card.  
 If the CPUM security settings change, for example, using the keys on the front panel of the card, then the Read Security Settings button must be used to read the security settings from the card (as the CPUM Security window does not update automatically).

---

### 4.3.3 Allowing or blocking access to the CPUM

CPUM access is allowed by default so that the CPUM card and VM600 rack can communicate with the VM600 MPSx software and compatibility with earlier versions of CPUM firmware is maintained.

To block access to a CPUM card (and limit the VM600 MPS to “read only” operations):

- When CPUM access is allowed, simultaneously pressing the OUT-, SLOT- and SLOT+ keys on the front panel of the CPUM card will block access to the card, that is, the **CPUM Access Lock** setting toggles from **Unlocked** to **Locked**.

To indicate that the CPUM card is locked, the DIAG LED on the front panel of the CPUM card slowly blinks green (approximately once per second). See Table 4-3.

To allow access to a CPUM card:

- When CPUM access is blocked, simultaneously pressing the OUT-, SLOT- and SLOT+ keys on the front panel of the CPUM card will allow access to the card, that is, the **CPUM Access Lock** setting toggles from **Locked** to **Unlocked**.

To indicate that the CPUM card is unlocked, the DIAG LED on the front panel of the CPUM card shows green (continuously). See Table 4-3.

In addition, after changing the CPUM access setting, the **CPUM Security** window in the VM600 MPSx software can be used to display (refresh) the CPUM security settings (by running the **Read Security Settings** command).

**Table 4-3:** CPUM access and the behaviour of the CPUM’s DIAG LED

Behaviour of the CPUM’s DIAG LED	Event(s)
Green (continuous)	Access to the CPUM card is allowed ( <b>CPUM Access Lock: Unlocked</b> )
Green blinking slowly (approximately once per second)	Access to the CPUM card is restricted ( <b>CPUM Access Lock: Locked</b> ). See Table 4-1.
Green blinking quickly (approximately twice per second) for five seconds	The CPUM card is resetting to its default security settings. See 4.3.7 Resetting the CPUM security settings.

#### 4.3.4 Enabling and disabling MPS password validation on a CPUM

MPS password validation on a CPUM card is disabled by default so that the CPUM card can communicate with the VM600 MPSx software and compatibility with earlier versions of CPUM firmware is maintained.

---

**NOTE:** CPUM access must be allowed (**CPUM Access Lock: Unlocked**) in order to work with MPS password validation.

---

To enable password validation on a CPUM card (and limit the VM600 MPS to “read + restricted write” operations):

- 1- Click on a rack level node in the configuration tree to select it, then use the **Communications > CPUM security** menu command.  
Alternatively, right-click on a rack level node in the configuration tree, then click **CPUM security**.
- 2- In the **CPUM Security** window that appears, under **CPUM Security Settings**, for the **MPS Password Validation** field, click the **Enable** option.
- 3- In the **Set CPUM Password** window that appears, enter the new password and enter the new password again to confirm it, then click **OK**.  
The CPUM password is set, CPUM password validation is enabled, and the **CPUM Security** window updates.

MPS password validation is enabled and the **CPUM Security** window updates.

#### 4.3.5 Changing the password on the CPUM

To change the password used by a CPUM card for authentication:

- 1- In the **CPUM Security** window, under **CPUM Security Settings**, for the **CPUM Password Validation** field, click the **Change CPUM Password** button.
- 2- In the **Change CPUM Password** window that appears, enter the old password and the new password, and enter the new password again to confirm it, then click **OK**.

The CPUM password is set, CPUM password validation is enabled, and the **CPUM Security** window updates.

---

**NOTE:** CPUM access must be allowed (**CPUM Access Lock: Unlocked**) in order to work with MPS password validation

---

#### 4.3.6 Logging on and off a CPUM

When MPS password validation on the CPUM card is used, whenever the VM600 MPSx software is asked to perform a restricted operation (for example, Alarm Reset (AR)), the software will prompt the user for the CPUM password before continuing.

If the correct CPUM password is used, then the VM600 MPSx software will automatically log on to the CPUM card and perform the requested operation. When the software logs on to the CPUM card in this way, it will remain logged on to the CPUM card in a “session” until the **CPUM Security** window is used to log off from the CPUM card or the software is closed (exited).

In a session, it is not necessary re-enter the CPUM password every time a restricted operation is requested. However, such sessions also have a timeout of 10 minutes, so if no

restricted command (that is, a command normally requiring a password) is run during a 10 minute period, then the session automatically logs off.

However, if an incorrect CPUM password is used, then VM600 MPSx software will not log on to the CPUM card and the requested operation is not performed.

To manually log on to a CPUM card:

- 1- In the **CPUM Security** window, under **CPUM Security Settings**, for the **Session Information** field, click the **Log On To CPUM card** button.
- 2- In the **CPUM Login** window that appears, enter the password, then click **OK**.

The VM600 MPSx software is logged on to the CPUM card and the **CPUM Security** window updates.

To log off from a CPUM card:

- 1- In the **CPUM Security** window, under **CPUM Security Settings**, for the **Session Information** field, click the **Log Off From CPUM card** button.

The VM600 MPSx software is logged off from the CPUM card and the **CPUM Security** window updates.

If the CPUM security settings change, for example, using the keys on the front panel of the card, or the VM600 MPSx software is closed (exited), any open sessions with a CPUM card are automatically closed (logged off).

### 4.3.7 Resetting the CPUM security settings

If necessary, the CPUM security settings can be reset to their default values of:

- **CPUM Access Lock: Unlocked**
- **MPS Password Validation: Disabled.**

When the CPUM security settings are reset, any open sessions with the CPUM card are automatically closed:

- **Session Information: Logged off.**

---

**NOTE:** Physical access to CPUM card (VM600 rack) is required in order to reset the CPUM security settings to their default values.

---

To reset the CPUM security settings:

- Simultaneously press and hold the OUT-, SLOT- and SLOT+ keys on the front panel of the CPUM card for five seconds.

To indicate that the CPUM card is reset, the DIAG LED on the front panel of the CPUM card quickly blinks green (approximately twice per second) for five seconds. Then, the DIAG LED resumes normal operation (continuous green when the CPUM is running correctly and off when the CPUM is starting).

In addition, after resetting the CPUM security settings, the **CPUM Security** window in the VM600 MPSx software can be used to display (refresh) the CPUM security settings (by running the **Read Security Settings** command).

## 4.4 CPUM Configurator software

CPUM Configurator is included with VM600 MPSx software version 2.7 or later and is copied to the computer as part of the VM600 MPSx software installation process. Previously, CPUM Configurator was only available from Meggitt Sensing Systems customer support (see 17.1 Contacting us).

CPUM Configurator is a program that communicates with a CPUM card in a VM600 rack over an Ethernet (TCP/IP) link. Basically, it provides a graphical user interface for a Telnet session between a CPUM Configurator (Telnet client) and a CPUM card (Telnet server), and is used primarily for configuring and managing CPUM cards / VM600 racks

---

**NOTE:** Refer to the *VM600 Networking* manual for further information on the CPUM Configurator software.

---

**THIS PAGE INTENTIONALLY LEFT BLANK**

## 5 CREATING THE CONFIGURATION TREE

### 5.1 Introduction

This section describes how to create the configuration tree structure. This outline of the system ("skeleton") of the configuration defines the overall structure of the machinery protection system. It must be created before individual cards can be configured.

See 2.2 VM600 MPS configuration for further information.

The first step is to determine how many databases are required for the site being monitored by the protection system and to create the databases necessary.

### 5.2 Creating databases

When you enter the VM600 MPS1 Configuration Editor main window for the first time after installation, the default configuration tree structure is shown on the left of the window (see Figure 5-1).

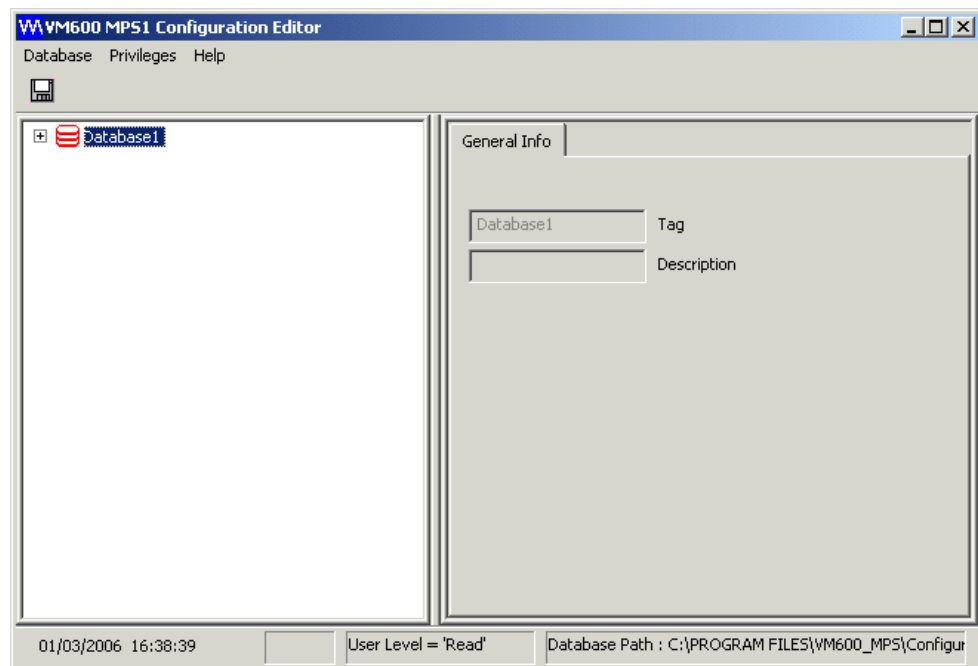

**Figure 5-1:** Main window of the VM600 MPS1 Configuration Editor (VM600 MPSx software)

A single database is created by default during installation. To configure your first database, you can choose to either reconfigure this default database or create a new database.

There are two ways to create new databases:

- Using the Database Manager. See 6.2.3 Using the Database Manager for details.
- Using the New Database command on the Database menu. This procedure is described below.

To create a new database using the New Database command on the Database menu:

- 1- Switch to the Super privilege level (see 4.2.1 Selecting the privilege level).
- 2- Select **New Database** from the **Database** menu at the top of the main window of the VM600 MPS1 Configuration Editor. The dialog box shown in Figure 5-2 appears.

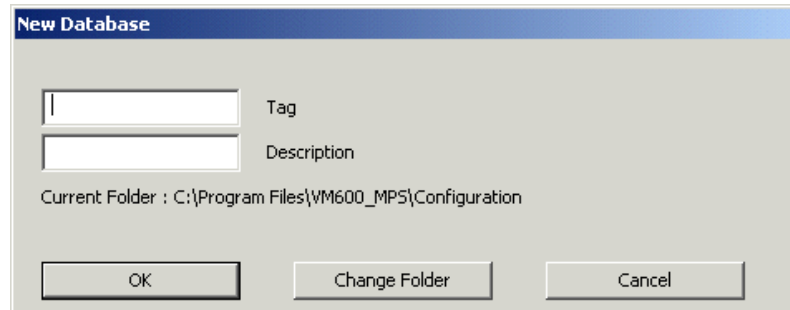
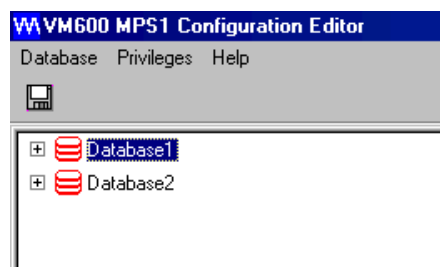

**Figure 5-2:** New Database dialog box

- 3- Type a name for the database in the **Tag** field. This name must be unique, that is, two or more databases cannot have the same name.
- 4- Optionally, type a description of the database in the **Description** field to provide further information. Any text entered is visible as a cue card when the mouse pointer is placed on the icon in the configuration tree structure representing the database.
- 5- Optionally, click **Change Folder** to modify the default folder in which the physical database file is to be stored. Navigate to and select a different folder, then click **OK** to continue.

By default, databases are created in the VM600\_MPS1\Configuration folder and have a .db file name extension.

Figure 5-3 shows the appearance of the configuration tree structure when two databases have been created.



**Figure 5-3:** Configuration tree structure showing two new databases

### 5.3 Adding a rack to a database

There are two methods of attributing a VM600 rack to a database. Either:

- a. Choose the **New Rack** command from the **Database** drop-down menu as shown in Figure 5-4 (a)

or

- b. Alternatively, select the database name in the configuration tree structure using the left mouse button. Then, right-click to obtain the shortcut menu shown in Figure 5-4 (b). Choose the **New Rack** command.

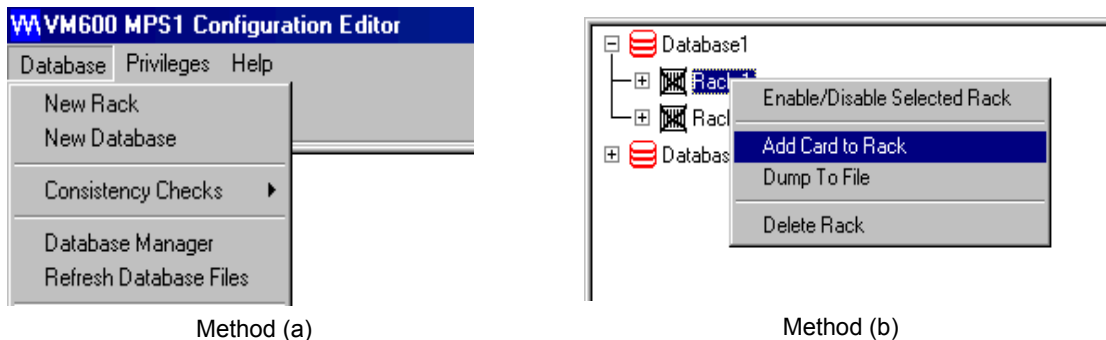

**Figure 5-4:** Adding a rack to a database

Once the New Rack dialog box appears (Figure 5-5), type a name for the rack in the **Tag** field. This name must be unique, that is, two or more racks cannot have the same name.

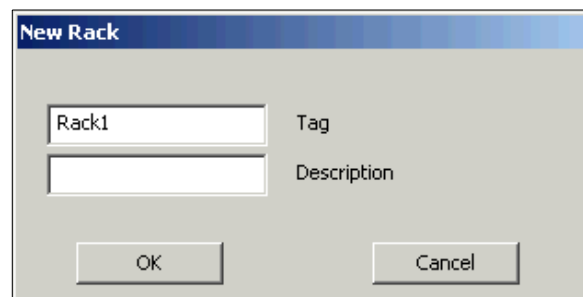

**Figure 5-5:** New Rack dialog box

Optionally, some descriptive text can be entered in the **Description** field to provide further information. The text you type is visible as a cue card when the mouse pointer is placed on the icon in the configuration tree structure representing the rack.

Click **OK** to close the dialog box.

If the rack contains a CPUM card, the rack's network address can be configured at this stage. To do this, click the rack's name in the configuration tree structure to obtain the rack **General Information** tab (see Figure 5-6). Select the **CPU Present** check box, then in the **Hostname** field, either select a predefined host name or type the rack IP address, in dot-decimal notation, directly (for example, 255.255.255.255).

---

**NOTE:** Refer to the *VM600 Networking* manual for further information on networking.

---

If desired, text can be entered into the **Description** and **Location** fields. This operation is optional, but these text entries can serve as useful comments for other users.

The **Rack Rear Layout** check boxes and the other tabs (**Backplane Bus View** and so on) are described in 16 Configuration windows at rack level.

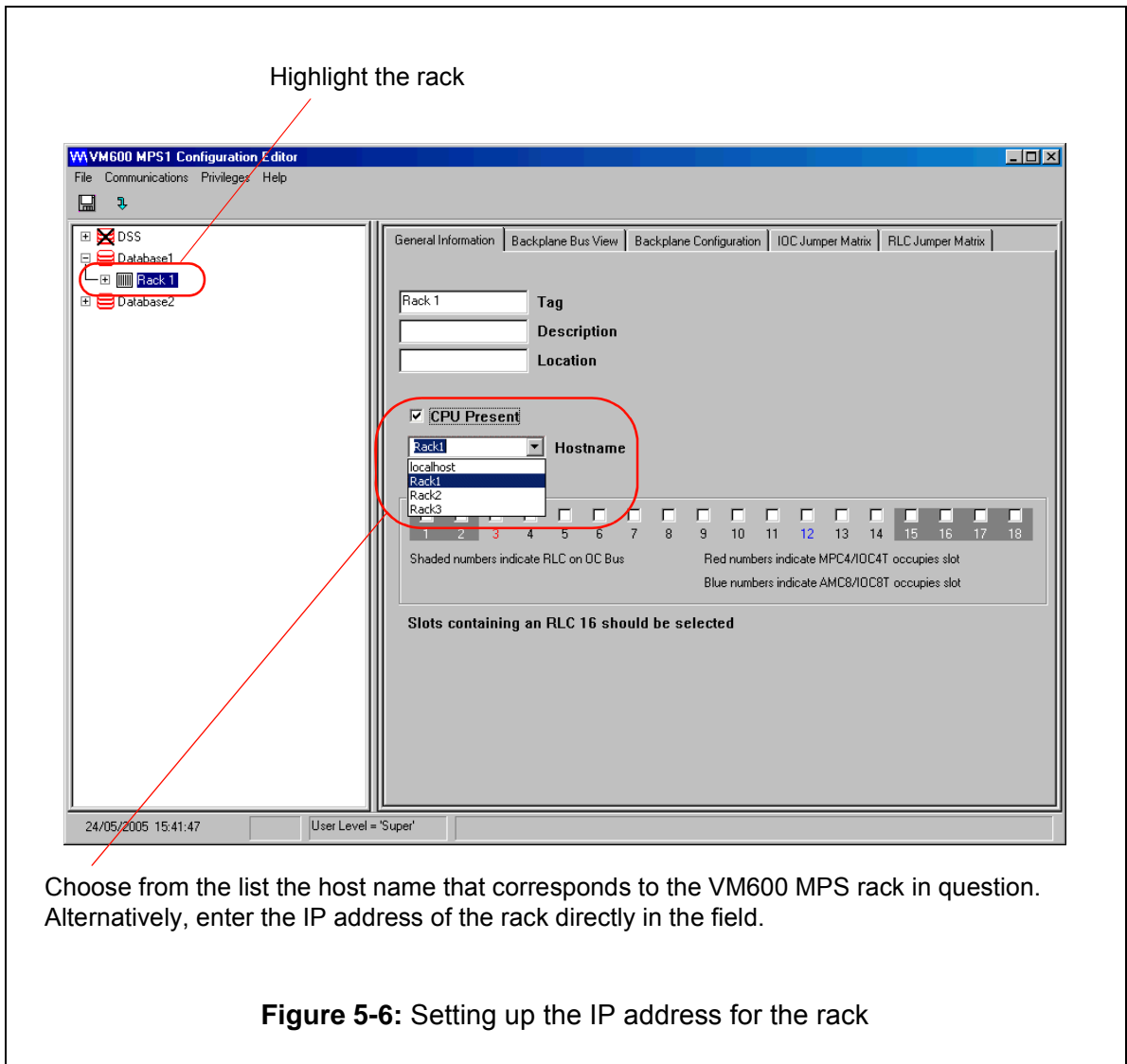

## 5.4 Adding cards to a rack

There are three methods of attributing cards (MPC4, AMC8) to a VM600 rack:

- a. Choose the **Add Card to Rack** command from the **File** drop-down menu as shown in Figure 5-7 (a).

*or*

- b. Alternatively, highlight the rack name in the configuration tree structure using the left mouse button. Then, right-click to obtain the shortcut menu shown in Figure 5-7 (b). Choose the **Add Card to Rack** command.

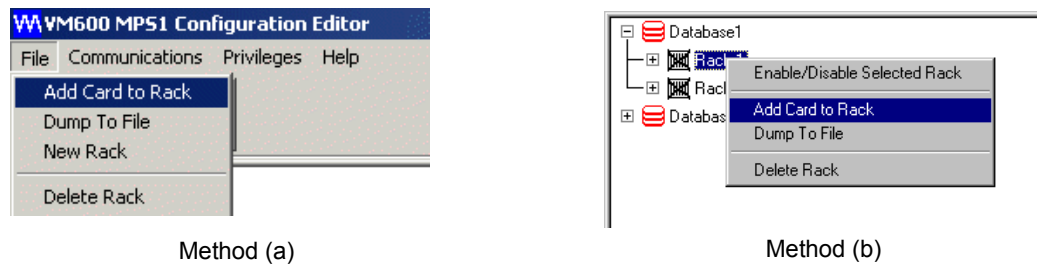

**Figure 5-7:** Adding a card to a rack

or

- c. Drag and drop. Press and hold down the SHIFT key then click an existing card. Drag the card to the rack and release. This creates a copy of the card.

Once the New Card dialog box appears (Figure 5-8), choose a card from the **Card Type** combo box: **AMC8**, **MPC4** or **MPC4 SIL**.

---

**NOTE:** The MPC4 machinery protection card is available in different versions, including a standard version and a separate circuits version that are referred to as **MPC4** in the VM600 MPSx software, and a safety (SIL) version that is referred to as **MPC4 SIL** in the VM600 MPSx software.

The MPC4 SIL (safety MPC4 card) does not have a VME bus interface and does not provide all of the signal processing capabilities of the standard and the separate circuits versions of the MPC4.

Refer to the *MPC4 machinery protection card* data sheet and the *VM600 Machinery Protection System (MPS)* hardware manual for further information.

---

You must then assign a value in the **Slot Number** field.

Optionally, some descriptive text can be entered in the **Description** field to provide further information. This operation is optional. Any text entered is visible as a cue card when the mouse pointer is placed on the icon in the configuration tree structure representing the card.

The Import key allows a pre-existing configuration file for a card to be loaded. These files have a `.cfg` file name extension.

Click **OK** to close the dialog box.

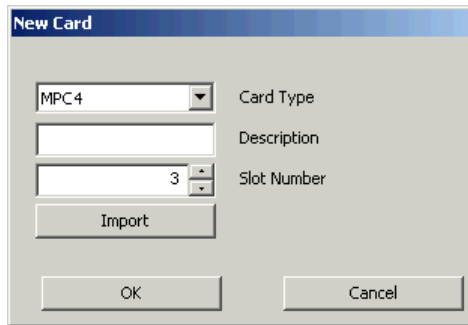

**Figure 5-8:** New Card dialog box

Figure 5-9 shows a typical configuration tree structure once several cards have been assigned to racks and databases.

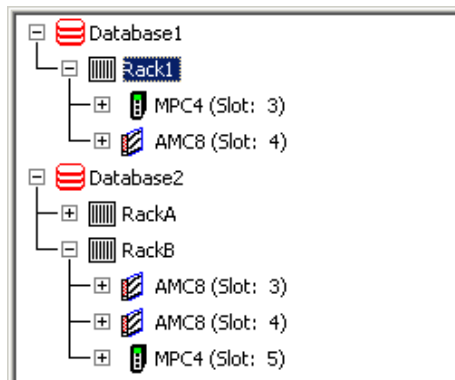

**Figure 5-9:** Configuration tree structure containing several databases, racks and cards

## 6 MAIN WINDOW MENUS AND COMMANDS

### 6.1 Introduction

The appearance of the main window of the VM600 MPS1 Configuration Editor (VM600 MPSx software) depends on what sort of element (database, rack or card) is selected in the configuration tree structure. This also determines which drop-down menus are available.

### 6.2 Main window at database level (managing databases)

At database level, the VM600 MPS1 Configuration Editor main window resembles that shown in Figure 6-1.

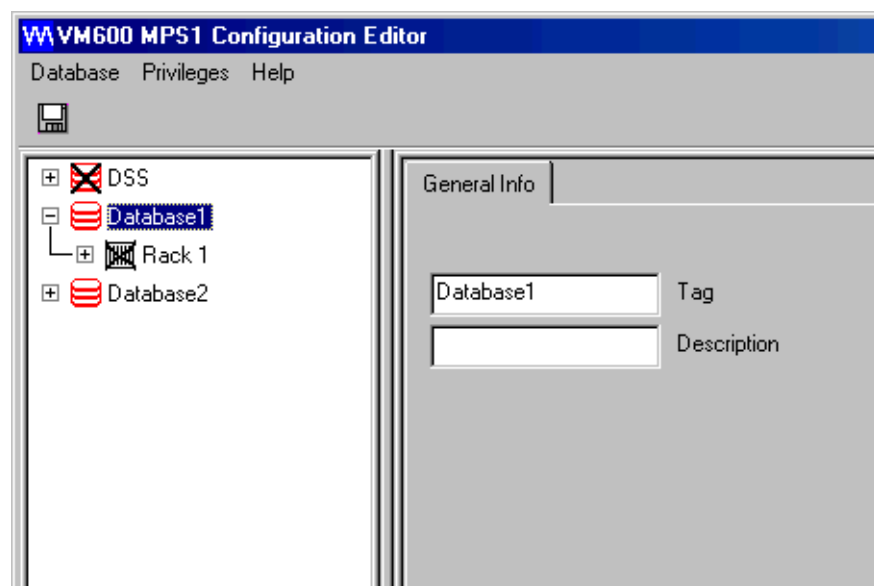
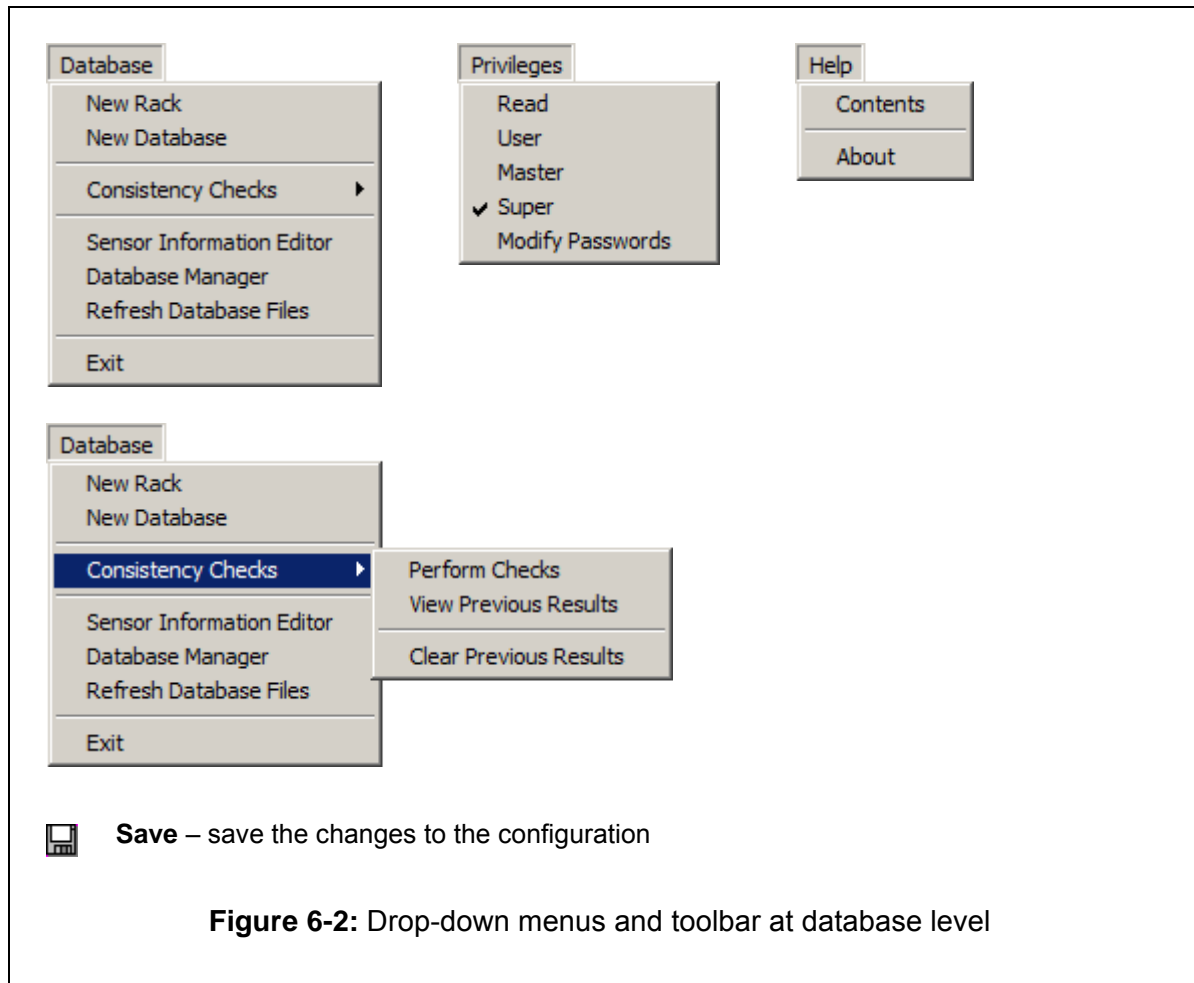

**Figure 6-1:** VM600 MPS1 Configuration Editor main window at database level

The **General Information** tab contains the following fields:

<b>Tag</b>	Allows the database name to be changed.
<b>Description</b>	Optionally, some descriptive text can be entered here. This text is visible when the mouse pointer is placed on the database icon in the configuration tree structure.

The contents of the drop-down menus are shown in Figure 6-2. This figure also explains the elements in the toolbar.



The **Database** drop-down menu contains the following choices:

- New Rack** Adds a new rack to the selected database.
- New Database** Adds a new database to the VM600 MPS1 Configuration Editor.
- Consistency Checks > Perform Checks** Checks the validity of the files in the selected database. See 6.2.1 Performing consistency checks for further information.
- Consistency Checks > View Previous Results** Displays the results of the previous consistency checks for the selected database. See 6.2.1 Performing consistency checks for further information.
- Consistency Checks > Clear Previous Results** Clears (deletes) the results of all previous consistency checks for the selected database. See 6.2.1 Performing consistency checks for further information.
- Sensor Information Editor** Starts the Sensor Information Editor program. See 6.2.2 Using the Sensor Information Editor for further information.

---

<b>Database Manager</b>	Starts the Database Manager program. See 6.2.3 Using the Database Manager for further information.
<b>Refresh Database files</b>	Updates the version information in the selected database to the latest release and performs any necessary updates.
<b>Exit</b>	Exits (stops) the VM600 MPS1 Configuration Editor software.

The **Privileges** drop-down menu allows one of the four privilege levels to be set and passwords to be changed. See 4.2.1 Selecting the privilege level for further information.

The **Help** drop-down menu allows the offline help concerning the VM600 MPS1 software to be accessed.

### 6.2.1 Performing consistency checks

Consistency checks are used to check the validity of the files in the selected database.

To perform consistency checks, choose **Database > Consistency Checks > Perform Checks**.

The VM600 MPS1 software also performs consistency checks automatically whenever:

- Switching to the Super privilege level (see 4.2.1 Selecting the privilege level).
- Closing (exiting) the Database Manager utility (see 6.2.3 Using the Database Manager).

The Consistency Checks window is displayed, as shown in Figure 6-3.

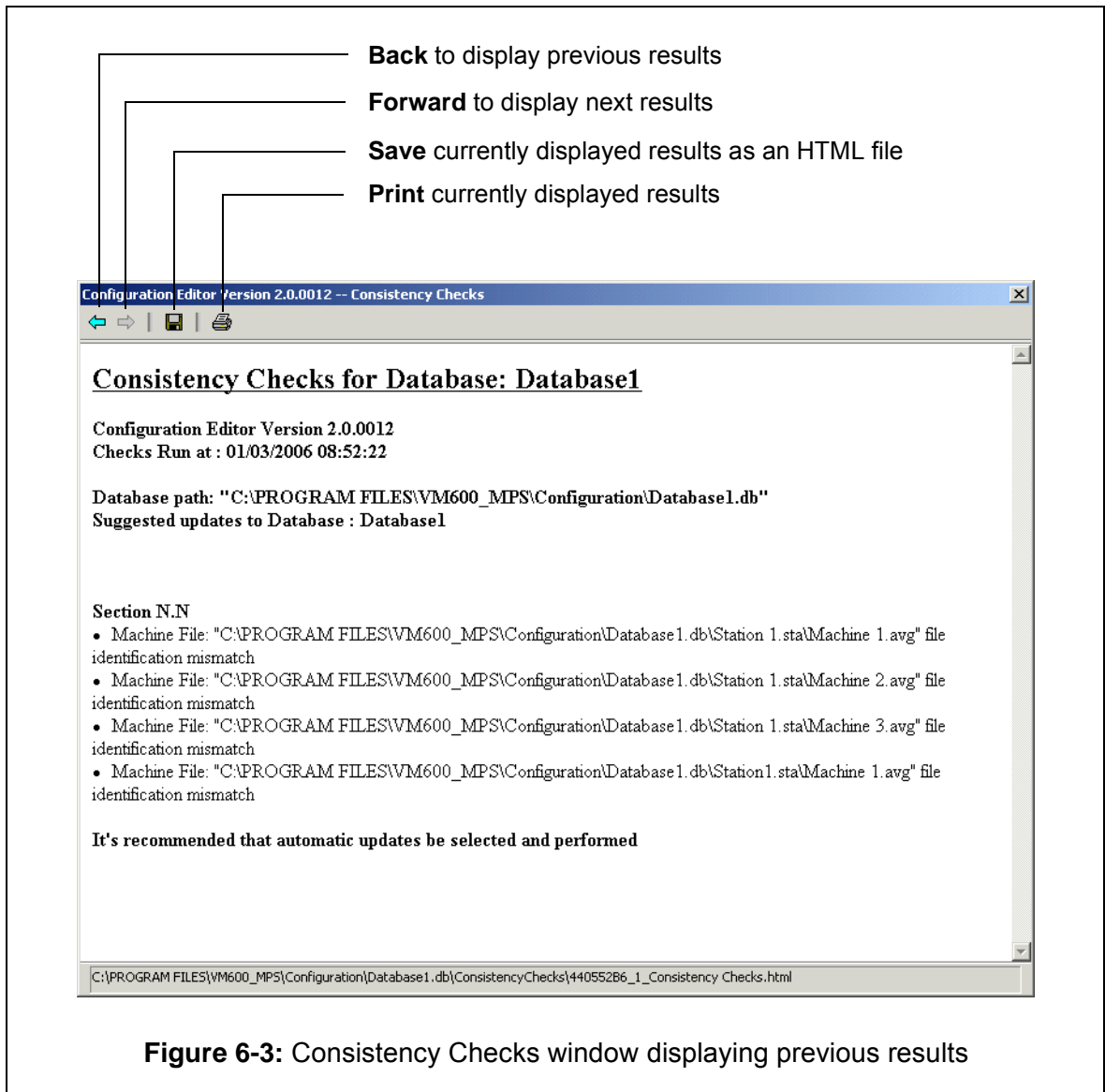

The Consistency Checks window lists the results of a number of checks that the VM600 MPS1 software carries out on the current database:



- Verifying that read/write access is granted to all database files.
- Checking that the `dbinfo.db` file exists.
- Converting rack files created with previous versions of the VM600 MPSx software to the latest version.
- Checking for file name extension mismatches in early machine files.
- Searching for blank tags in MPC and AMC configurations.
- Checking for AMC Board Level information problems due to the incorrect initialisation of remote source channels 1 and 2 (**Remote Channel Source #1** and **#2**).

If any errors or inconsistencies are found, the VM600 MPS1 software can automatically perform any database updates necessary. It is strongly recommended that you perform these updates. Click the icon on the toolbar of the Consistency Checks window to perform automatic updates.

The VM600 MPS1 software stores the results of previous consistency checks in order to allow you to refer to them later if necessary. You can use the following commands on the **Database > Consistency Checks** menu to check the results of previous consistency checks:

- **View Previous Results**

Displays the last Consistency Check file(s) created for the current database. You can step back through earlier files by clicking the 'Back' button on the toolbar (see Figure 6-3).

Alternatively, you can click the  and  icons on toolbar of the Consistency Checks window to display the previous and next set of results, respectively.

- **Clear Previous Results**

Deletes all Consistency Check files created for the current database.

Alternatively, click the icon on the Consistency Checks window to display the previous results.

## 6.2.2 Using the Sensor Information Editor

The Sensor Information Editor allows the underlying sensor list used by the VM600 MPS Configuration Editor software to be customised and managed. More specifically, it allows the addition, removal or modification of all types of sensors used by the Speed and Vibration channel configuration pages in the VM600 MPS software.

When the VM600 MPSx software (MPS1 or MPS2) is being used to configure the input channels for an MPC4 card, it uses the information provided in a sensor list file that is copied to the computer as part of the VM600 MPS software installation process.

### 6.2.2.1 Background

The sensor list file provides the information that is used to populate the drop-down list boxes and text boxes of the VM600 MPS software user interface when input channels (Measurement Channels and Speed Channels) are being configured. The sensor list file includes detailed information on the measurement chains (sensors/signal conditioners) for the different sensor systems that are available from Meggitt Sensing Systems, that is, information such as Sensor Family, Sensor Type, Conditioner, Transmission Mode and Signal Sensitivity.

Using the Sensor Information Editor helps to make the management of VM600 MPSx software configurations easier. For example, consider a specific measurement chain (sensor/conditioner), used by multiple input channels, that is required to be modified.

Without the Sensor Information Editor: In each input channel tab in the VM600 MPSx software where the measurement chain is used (Channel 1, Channel 2 and so on), the same parameters for the sensor/conditioner must be manually edited.

With the Sensor Information Editor: The sensor/conditioner can be edited once and saved to the sensor list file, after which the VM600 MPS software will automatically apply the changes wherever the measurement chain is used.

### 6.2.2.2 Starting the Sensor Information Editor

The Sensor Information Editor is started from the VM600 MPS software.

Click **Database > Sensor Information Editor** to start the Sensor Information Editor.

**NOTE:** To start the Sensor Information Editor, a Database must be selected in the configuration tree of the VM600 MPS software user interface and the VM600 MPSx software privilege level must be Super (see 4.2 VM600 MPSx software privilege levels).

When the Sensor Information Editor is started, the VM600 MPS software automatically closes and when the Sensor Information Editor is closed (exited), the VM600 MPS software is automatically restarted. This system behaviour is required in order to allow the software to read and apply any changes that have been made to the underlying sensor list file.

**6.2.2.3 Sensor Information Editor user interface**

The Sensor Information Editor user interface (see Figure 6-4) consists of two panes: a **Sensor List** pane (left) and a **Sensor Information** pane (right).

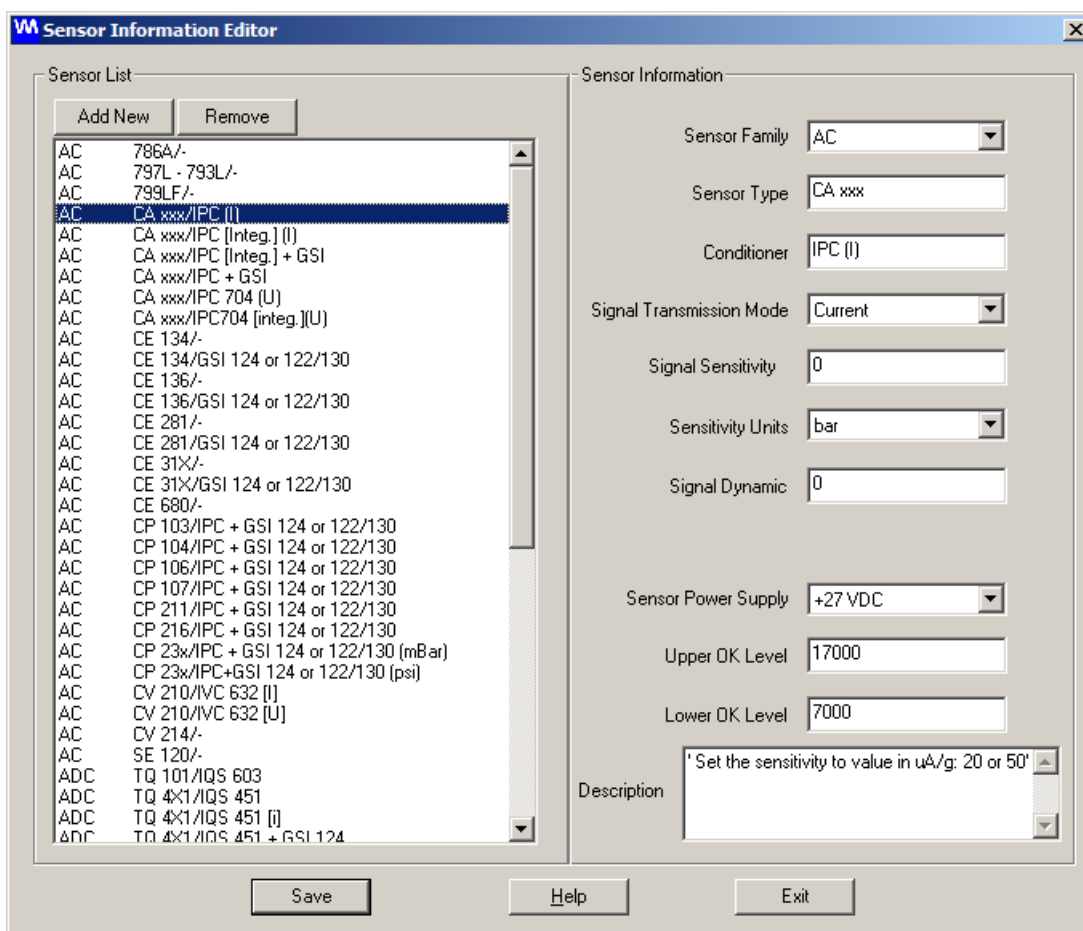

**Figure 6-4:** VM600 MPS software Sensor Information Editor window

The Sensor List pane (left) is used to select a sensor/conditioner to edit, add a new sensor/conditioner to the sensor list file and remove a sensor/conditioner from the sensor list file:

- 1- Click on a sensor/conditioner in the Sensor List pane to select it.  
The selected sensor/conditioner is shown against a dark background in the Sensor List pane and the parameters for the sensor/conditioner are displayed in the Sensor Information pane, where they can be edited.

- 2- Click **Add New** in the Sensor List pane to add a new sensor/conditioner.  
The new sensor/conditioner is shown against a dark background in the Sensor List pane and the empty parameters for the new sensor/conditioner are displayed in the Sensor Information pane, where they can be edited.
- 3- Click on a sensor/conditioner in the Sensor List pane to select it, then click **Remove** to remove it. The sensor/conditioner is removed from the Sensor List pane.  
The Sensor Information pane (right) is used to edit the parameters for the sensor/conditioner selected in the Sensor List pane (left).
- 4- Click **Save** to save any changes made in the Sensor Information Editor to the sensor list file.
- 5- Click **Exit** to close (exit) the Sensor Information Editor.

The user will be prompted to save any unsaved changes in the Sensor Information Editor to the sensor list file before the program is closed.

Click **Help** or press the **F1** key to display the help on using the Sensor Information Editor.

#### 6.2.2.4 Factory assigned defaults

If it becomes necessary to revert back to the default sensor list file provided by Meggitt Sensing Systems, a batch file included in the VM600 MPS software folder can be used.

---

**NOTE:** The default installation folder for the VM600 MPS software is  
`C:\Program Files\VM600_MPS`

---

---

**NOTE:** The default location for the Windows Program Files folder depends on the operating system installed on the computer:  
`C:\Program Files` on 32-bit versions of Windows, but  
`C:\Program Files (x86)` on 64-bit versions of Windows.

---

Reverting back to the default sensor list file will cause any changes that have been made to the sensor list file by the user to be lost.

To revert back to the default sensor list file, use a Windows Explorer to navigate to the Bin folder under the VM600 MPS software folder (`VM600_MPS\Bin`) and double-click the `sensors_factory.bat` file.

### 6.2.3 Using the Database Manager

The Database Manager allows you to manage the databases created to contain VM600 MPS configuration data.

#### 6.2.3.1 Starting the Database Manager

The Database Manager is started from the VM600 MPS software.

Click **Database > Database Manager** to start the Database Manager.

---

**NOTE:** To start the Database Manager, a Database must be selected in the configuration tree of the VM600 MPS software user interface and the VM600 MPSx software privilege level must be Super (see 4.2 VM600 MPSx software privilege levels).

---

When the Database Manager is started, the VM600 MPS software automatically closes and when the Database Manager is closed (exited), the VM600 MPS software is automatically restarted. This system behaviour is required in order to allow the VM600 MPS software to read and apply any changes that have been made to the underlying database files.

**6.2.3.2 Database Manager user interface**

The Database Manager user interface (see Figure 6-5) consists of one main pane that lists the **MPS Databases** used by the VM600 MPS software and buttons that provide access to the database operations available in the VM600 MPS1 software.

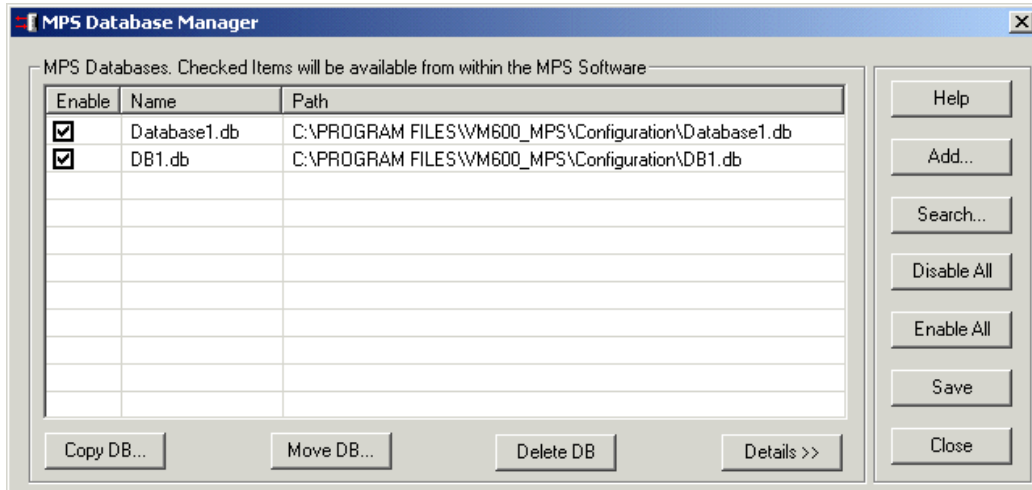

**Figure 6-5:** Database Manager window

**6.2.3.3 Using the Database Manager**

The VM600 MPS1 Database Manager provides the commands listed in Table 6-1.

**Table 6-1:** VM600 MPS software Database Manager commands

Command	Description
<b>Copy DB</b>	Creates a copy of the selected database and adds it to the active database list
<b>Move DB</b>	Moves the selected database to another location on your file system, and keeps it in the active database list
<b>Delete DB</b>	Deletes the selected database and all related files and removes it from the active database list
<b>Details</b>	Shows a list of all files in the selected database, their content and version
<b>Help</b>	Displays offline help (that is, the help installed locally on the computer)
<b>Add</b>	Creates a new database
<b>Search</b>	Searches the specified drive for a valid VM600 MPS database
<b>Disable All</b>	Disables all databases in the active database list
<b>Enable All</b>	Enables all databases in the active database list

Table 6-1: VM600 MPS software Database Manager commands (Continued)

Command	Description
Save	Saves changes in the active database list (applies to enabled databases only)
Close	Closes (exits) the Database Manager window

### 6.3 Managing racks

At rack level, the VM600 MPS1 Configuration Editor main window resembles that shown in Figure 6-6.

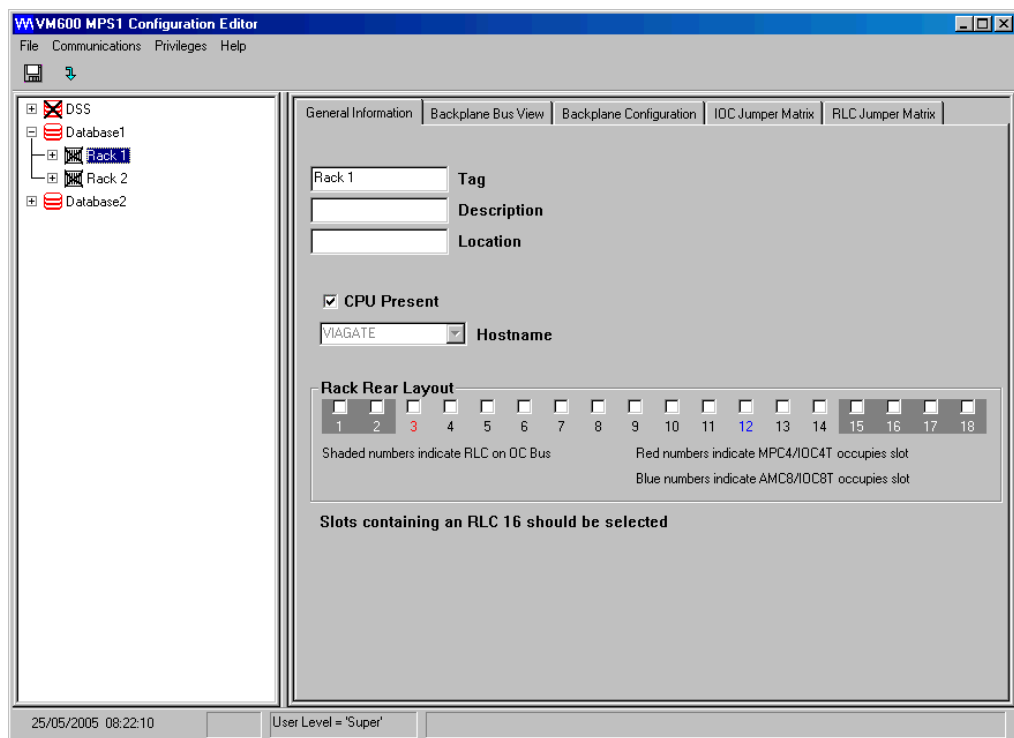

Figure 6-6: VM600 MPS1 Configuration Editor main window at rack level

The **General Information** tab contains the following fields:

- Tag** Allows the rack name to be entered or changed.
- Description** Optionally, some descriptive text can be entered here. This text is visible when the mouse pointer is placed on the rack icon in the configuration tree structure.  
This text also appears in the Rack Summary.
- Location** An optional text describing the rack location can be added here.  
This text appears in the Rack Summary.

If the rack contains a CPUM card, select the **CPU Present** check box, then select the name of the host from the predefined list in the **Hostname** list box. Alternatively, type the rack’s IP address, in dot-decimal notation, directly into the field (for example, 10.10.56.56).

**NOTE:** See 11.2 Communication with a stand-alone rack (no CPUM present) and 11.3 Communication with a networked rack (CPUM present) for further information.  
 Refer to the *VM600 Networking* manual for further information on networking.

The **Rack Rear Layout** check boxes and the other tabs (**Backplane Bus View**, and so) are described in 16 Configuration windows at rack level.

### 6.3.1 Drop-down menus and toolbar (with a rack selected)

The contents of the drop-down menus are shown in Figure 6-7. This figure also explains the elements in the toolbar.

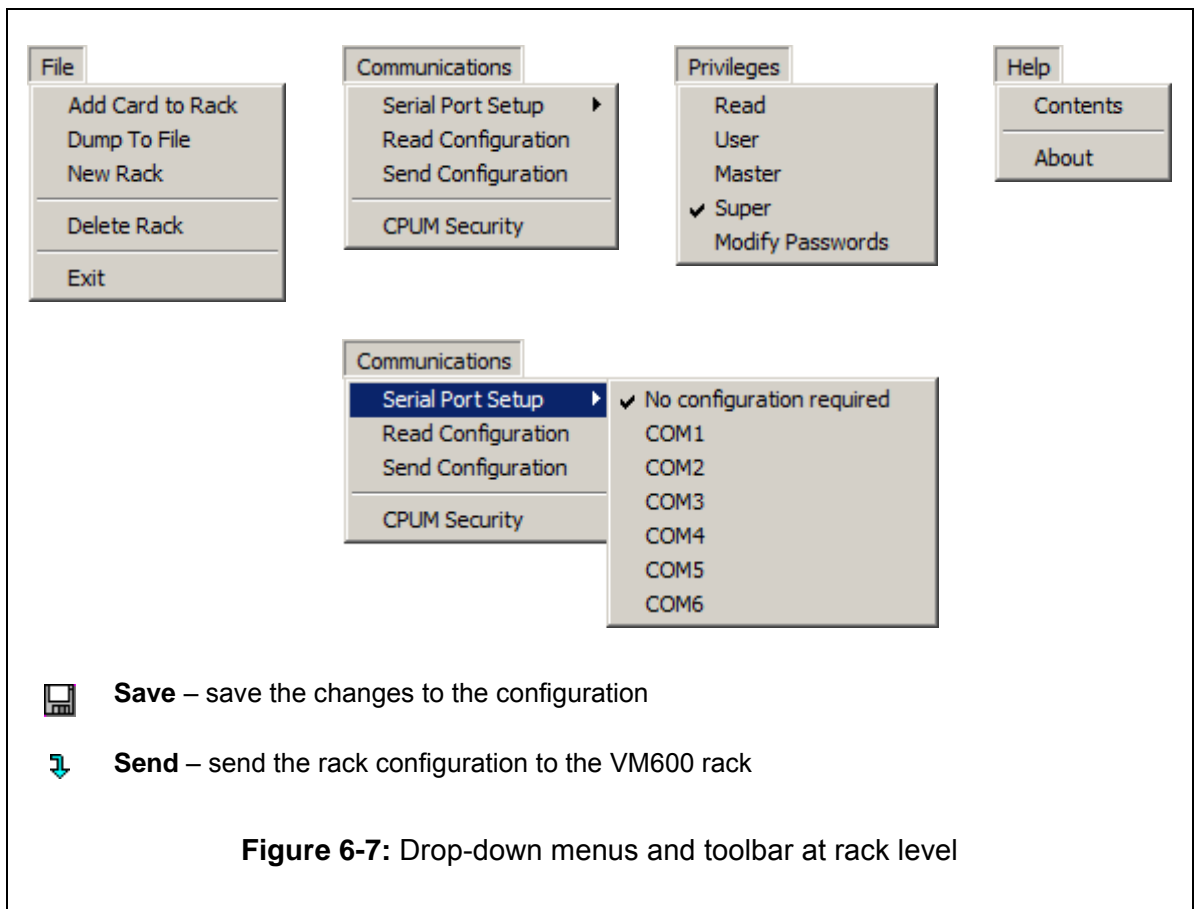

The **File** drop-down menu contains the following choices:

- Add Card to Rack** Adds a card (such as MPC4 or AMC8) to the rack highlighted by the mouse pointer.
- Dump to File** Saves the rack configuration in an external file using a comma-separated values file format (\*.CSV).  
This facilitates subsequent data processing by external programs such as spreadsheet software.
- New Rack** Adds a new rack to the database presently selected.
- Delete Rack** Deletes the rack highlighted by the mouse pointer.
- Exit** Exits (stops) the VM600 MPS1 software.

The **Communications** drop-down menu contains the following choices:

- |  |  |
|--|--|
| <b>Communications &gt;<br/>Serial Port Setup</b> | Choose the appropriate COMx serial interface port for RS-232 communications with the cards in a stand-alone VM600 rack (not containing a CPUM card).<br><br>The Serial Port Setup option is only available when the <b>CPU Present</b> check box (see Figure 6-6) is not selected. |
| <b>Read Configuration</b>                        | Reads the entire rack configuration from the selected rack, that is, the general rack parameters as well as the full configuration of each specific card in that rack.<br><br>A Rack Summary can then be obtained and printed if required.   |
| <b>Send Configuration</b>                        | Sends the entire rack configuration to the selected rack, that is, the general rack parameters as well as the full configuration of each specific card in that rack.<br><br>See 2.3.1.1 Safety (SIL) version of the MPC4.  |
| <b>CPUM Security</b>                             | Displays the <b>CPUM Security</b> window which allows the VM600 MPS rack (CPUM) security settings to be displayed and configured.<br><br>See 4.3 VM600 MPS rack (CPUM) security.   |

The **Privileges** drop-down menu allows one of the four privilege levels to be set and passwords to be changed. See 4.2.1 Selecting the privilege level for further information.

The **Help** drop-down menu allows the offline help concerning the VM600 MPS1 software to be accessed.

### 6.3.2 Shortcut menu (with a rack selected)

A shortcut menu is also available and is displayed when a rack-level node in the tree structure is right-clicked.

Most of the commands available from the shortcut menu are the same as those available from the **File** drop-down menu (see 6.3.1 Drop-down menus and toolbar (with a rack selected)). However, the shortcut menu does include some rack-level commands that are not available anywhere else.

Right-clicking on a rack provides access to the following additional commands:

- |                                     |  |
|-------------------------------------|--|
| <b>Enable/Disable Selected Rack</b> | Select or clear the <b>CPU Present</b> check box in the the <b>General Information</b> tab.<br><br>See 6.3 Managing racks.   |
| <b>CPUM Security</b>                | Displays the <b>CPUM Security</b> window which allows the VM600 MPS rack (CPUM) security settings to be displayed and configured.<br><br>See 4.3 VM600 MPS rack (CPUM) security. |

### 6.3.3 Sending a configuration to a VM600 rack or card

A configuration can be sent to a VM600 rack at one of two levels:

- Rack level – by selecting a rack in the configuration tree then using the **Communications > Send Configuration** menu bar command.
- Card level – by selecting a card (MPC4, MPC4 SIL or AMC8) in the configuration tree then using the **Communications > To AMC > Send Configuration** or **Communications > To MPC > Send Configuration** menu bar command as appropriate.

When sending a configuration to a VM600 rack or card, the VM600 MPSx software prompts the user for confirmation before continuing with the download.

---

**NOTE:** As the MPC4 SIL card does not have a VME bus interface, it cannot communicate with a CPUM card (or any other cards) in a VM600 rack. Accordingly, an MPC4 SIL card can only be configured via a direct connection to the RS-232 connector on its front panel (even for a “networked” VM600 rack). Refer to the *MPC4 machinery protection card* data sheet and the *VM600 Machinery Protection System (MPS)* hardware manual for further information.

---

## 6.4 Managing MPC4 and MPC4 SIL cards (card overview page)

If an MPC4 card is selected from the configuration tree structure, an overview page for that card is displayed in the main window (VM600 MPS1 Configuration Editor). A typical example is shown in Figure 6-8.

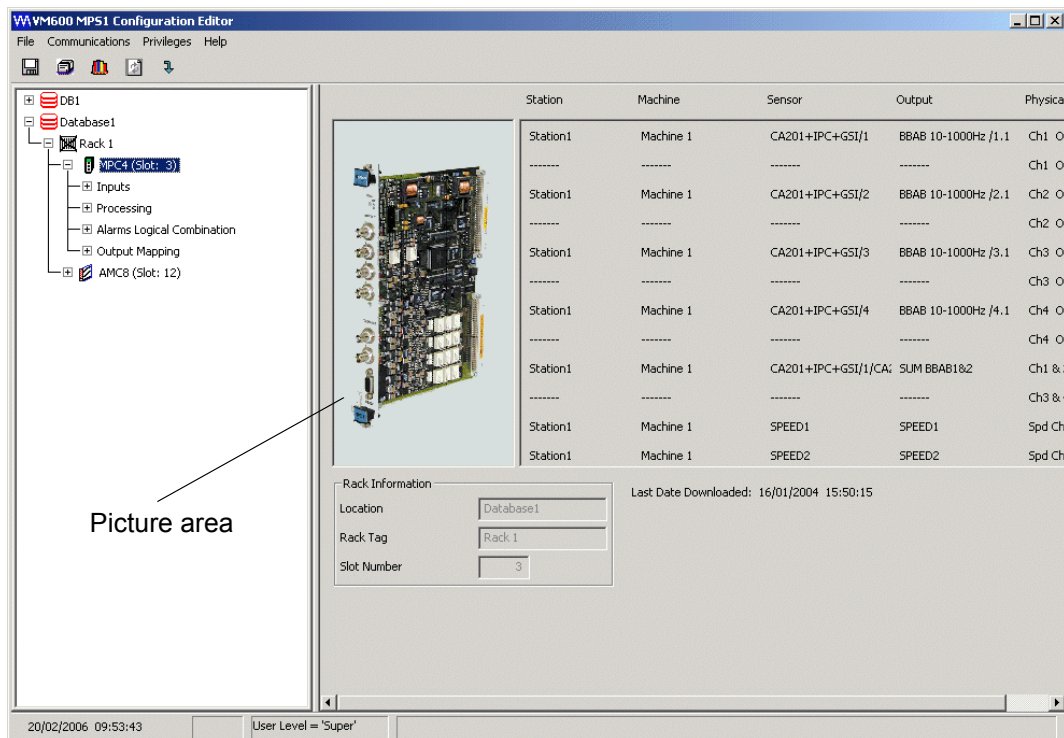

**Figure 6-8:** VM600 MPS1 Configuration Editor main window at MPC4 card level (card overview page)

The image of the card displayed in the VM600 MPS1 Configuration Editor main window (card overview page) is different for each type of MPC4 card, that is, MPC4 or MPC4 SIL. The image of the card shown in the picture area in Figure 6-8 corresponds to an MPC4.

The **Rack Information** area of the window contains the following non-editable fields:

<b>Location</b>	Indicates the database in which the rack's measurement data is stored.
<b>Rack Tag</b>	Identifies the rack in which the MPC4 card is inserted.
<b>Slot Number</b>	Indicates the slot of the rack in which the MPC4 card is inserted.

The **Station** and **Machine** columns are reserved for the VM600 MPS2 software package.

---

**NOTE:** Refer to the *VM600 MPS2 Configuration Software for Machinery Protection Systems* software manual for further information.

---

Some descriptive text concerning the measurement point may be found in the **Sensor** column.

For measurement channels, this text is copied from the text entered in the **Tag** field of the Processed Output tab (**Processing\Channel n** branch of tree structure selected). See 8 Processing configuration (MPC4 and MPC4 SIL).

For speed channels, this text is copied from the text entered in the **Sensor Tag** field (**Inputs\Speed Channels** branch of tree structure selected). See 7.3 Configuring speed channels.

A customised picture may be placed in the picture area. See 6.6 Displaying a customised picture on the card overview page for further information.

### 6.4.1 Drop-down menus and toolbar (with an MPC4 or MPC4 SIL card selected)

The contents of the drop-down menus are shown in Figure 6-9. This figure also explains the elements in the toolbar.

**File**

- Copy Inputs
- Copy Processings and Alarms
- Import MPC Configuration
- Export MPC Configuration
- Import Raw MPC Configuration
- Export Raw MPC Configuration
- Dump To File
- Add Card to Rack
- Delete MPC
- MPCC - General Information
- Exit

**Communications**

- To MPC
  - Send Configuration
  - Clear Status Latch Data
  - Alarm Reset
  - Channel Inhibits
- From MPC
  - Read Configuration
  - Read Outputs
  - Read System Status
  - Read System Identification
  - Read Status Latch Data

**Privileges**

- Read
- User
- Master
- ✓ Super
- Modify Passwords

**Help**

- Contents
- About

**Save** – save the changes to the configuration

**Summary** – display the summary sheet for the MPC4 or MPC4 SIL card

**Read Outputs** – display the outputs window for the MPC4 or MPC4 SIL card

**Refresh** – refresh the information displayed in the MPC4 or MPC4 SIL card overview page

**Send** – send the card configuration to the MPC4 or MPC4 SIL card

**Figure 6-9:** Drop-down menus and toolbar at MPC4 and MPC4 SIL card level

The **File** drop-down menu contains the following choices:

<b>Copy Inputs</b>	Allows the Inputs already configured for an MPC4 card to be re-used elsewhere on the same MPC4 card. That is, Measurement channels 1 to 4 and Speed Channels 1 to 2.
<b>Copy Processings and Alarms</b>	Allows the Processings and Alarms already configured for an MPC4 card to be re-used elsewhere on the same MPC4 card. That is, Processing channels 1 to 4, Dual Processing channel 1 & 2 and Dual Processing channel 3 & 4, including any alarms configured for the processing channel.
<b>Import MPC Configuration</b>	Loads an MPC4 card configuration from a pre-existing configuration file (*.cfg). This file is compatible with the previous Vibro-Meter MPCC software.
<b>Export MPC Configuration</b>	Saves an MPC4 card configuration in an external configuration file (*.cfg). This file is compatible with the previous Vibro-Meter MPCC software.
<b>Import Raw MPC Configuration</b>	Loads an MPC4 card configuration from a pre-existing configuration file (*.cfg).
<b>Export Raw MPC Configuration</b>	Saves an MPC4 card configuration in an external configuration file (*.cfg).
<hr/> <b>NOTE:</b> See below for an explanation of the difference between normal and raw configuration files. <hr/>	
<b>Dump to File</b>	Saves an MPC4 card configuration in an external file using a comma-separated values file format (*.csv).  This facilitates subsequent data processing.
<b>Add Card to Rack</b>	Adds a new MPC4 card to the rack presently selected.
<b>Delete MPC</b>	Deletes the MPC4 card highlighted by the mouse pointer.
<b>MPCC - General Information</b>	Allows additional information used by the previous Vibro-Meter MPCC software to be entered. This information is displayed at the top of the summary sheet for the MPC4 card.
<b>Exit</b>	Exits (stops) the VM600 MPS1 software.

#### 6.4.1.0.1 Difference between normal and raw configuration files

Normal MPC configuration files are files that can be created using Vibro-Meter's MPCC software, a predecessor of the VM600 MPS software packages. These can be imported into VM600 MPSx software. Conversely, the configuration of a specific MPC4 card can be created in VM600 MPS software and then exported, as this file is in a format that the MPCC software understands.



**Using the Raw configuration file format is recommended for advanced users only. Raw configuration files are in a format that is used and stored by the CPUM card in its disk structure. These files are used by the CPUM to reprogram (that is, configure) specific cards in the VM600 rack, if necessary. Contact your Meggitt Sensing Systems customer support representative for further information, if required.**

The **Communications** drop-down menu allows principally the MPC4 configuration information to be sent to the card and measured values to be read back from it. The **Communications** menu also allows channel inhibit commands to be sent to individual MPC4 input channels in order to temporarily bypass a sensor and the processing associated with it. See 11 Communications menu (MPC4 and MPC4 SIL) for further information on all the menu functions.

The **Privileges** drop-down menu allows one of the four privilege levels to be set and passwords to be changed. See 4.2.1 Selecting the privilege level for further information.

The **Help** drop-down menu allows the offline help concerning the VM600 MPS1 software to be accessed.

#### 6.4.2 Shortcut menu (with an MPC4 or MPC4 SIL card selected)

A shortcut menu is also available and is displayed when an MPC4 or MPC4 SIL card-level node in the tree structure is right-clicked.

Most of the commands available from the shortcut menu are the same as those available from the **File** drop-down menu (see 6.4.1 Drop-down menus and toolbar (with an MPC4 or MPC4 SIL card selected)). However, the shortcut menu does include some MPC4 card-level commands that are not available anywhere else.

Right-clicking on an **MPC4** or **MPC4 SIL** card provides access to the following additional command:

- MPC4 <--> MPC4 SIL Conversion** If a standard or separate circuits MPC4 card (**MPC4**) is selected, automatically convert the configuration to a configuration for a safety MPC4 card (**MPC4 SIL**).
- If a safety MPC4 card (**MPC4 SIL**) is selected, automatically convert the configuration to a configuration for a standard or separate circuits MPC4 card (**MPC4**).

As all of the features supported by a safety MPC4 card (**MPC4 SIL**) are also supported by a standard or separate circuits MPC4 card (**MPC4**), no configuration information is lost when converting from an **MPC4 SIL** to a **MPC4**.

However, not all of the features supported by a standard or separate circuits MPC4 card (**MPC4**) are supported by a safety MPC4 card (**MPC4 SIL**), so configuration information can

be lost when converting from an **MPC4** to a **MPC4 SIL**. For example, the safety MPC4 card (**MPC4 SIL**) card does not support the speed/phase reference (tachometer) input channels, the Narrow Band (Tracking) Vibration and  $S_{max}$  processing functions, and it does not support the danger bypass (DB) and trip multiply (TM) functions.

Refer to Table 7-1 in section 7.1 Different versions of the MPC4 card of the *VM600 Machinery Protection System (standard version)* hardware manual for further information.

Right-clicking on an **MPC4 SIL** card provides access to the following additional command:

**Check MPC4 SIL Configuration**

Run a consistency check on the configuration for a safety MPC4 card (**MPC4 SIL**) to ensure that it meets the requirements for use in a safety-related system. For example, alarms must be configured as latching, and output relays must be configured as normally energised (NE), that is, de-energised to trip.

As shown in Figure 6-10, when the **Check MPC4 SIL Configuration** command is run, the VM600 MPS software displays a message reminding the user to review the complete system configuration to identify any possible conflicts in the VM600 system rack.

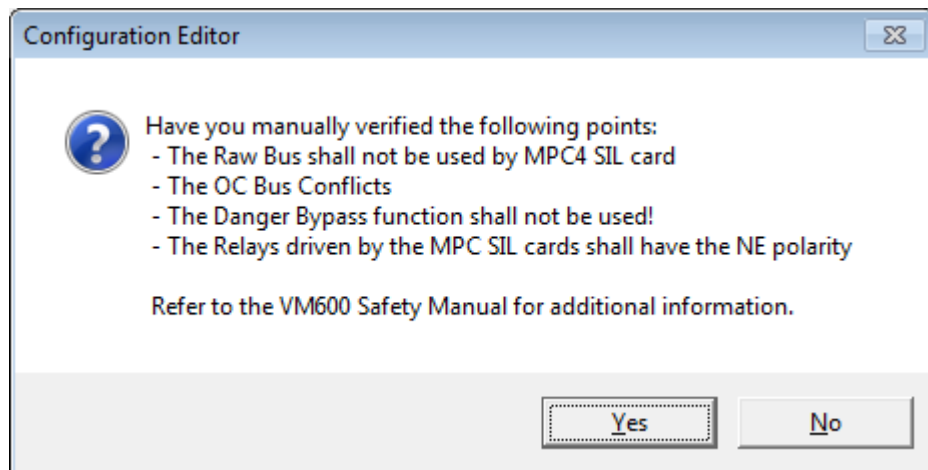

**Figure 6-10:** VM600 MPS1 Configuration Editor message displayed after running the **Check MPC4 SIL Configuration** command

After the **Check MPC4 SIL Configuration** command is run, the VM600 MPS software Consistency Checks window lists any safety-relevant configuration errors/warnings detected by the software for the safety MPC4 card (**MPC4 SIL**), as shown in Figure 6-11.

See also 6.2.1 Performing consistency checks.

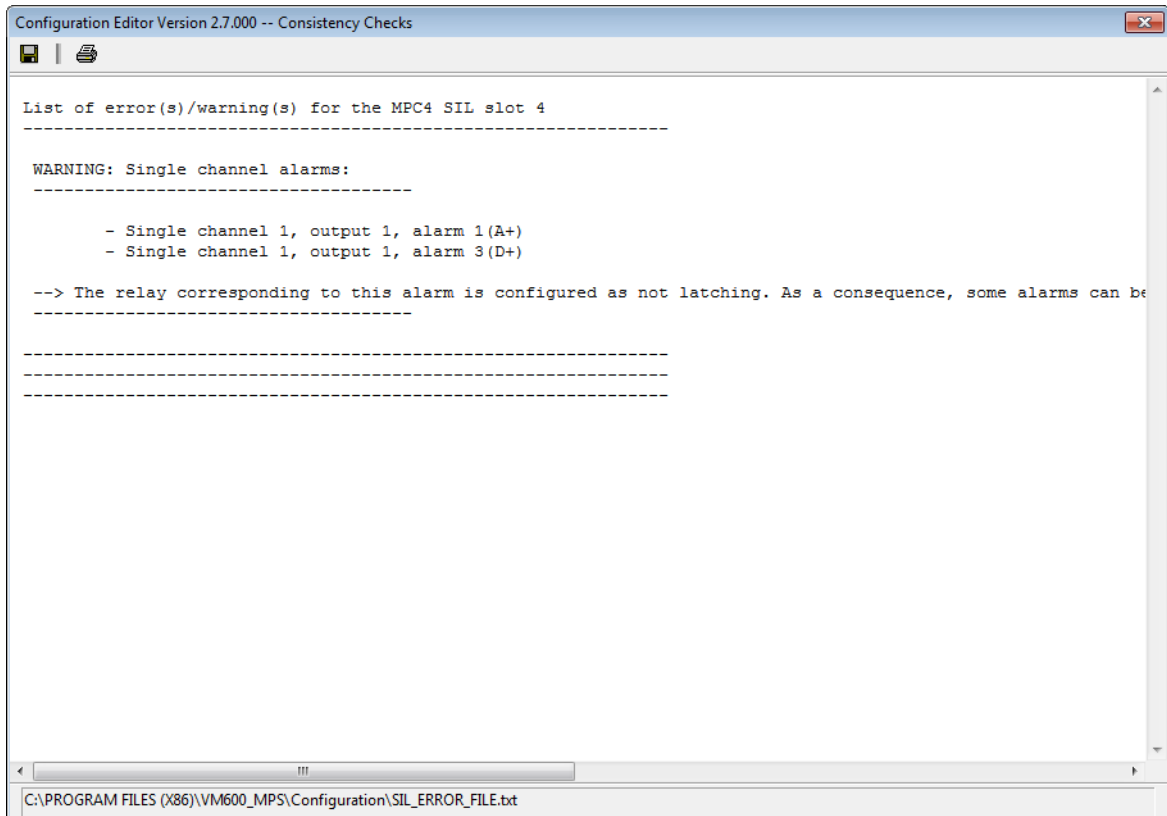

**Figure 6-11:** Example Consistency Checks window displayed after running the **Check MPC4 SIL Configuration** command

---

**NOTE:** While the MPC4 SIL consistency check (**Check MPC4 SIL Configuration** command) automatically checks the configuration of an individual safety MPC4 card (**MPC4 SIL**) and ensures that it meets the requirements for use in a safety-related system, a further manual check of the complete VM600 system configuration is required by the user in order to identify and avoid possible conflicts from additional cards in the VM600 rack. For example, due to VM600 Raw Bus and/or OC Bus issues.

Refer to section 1.7 Avoiding possible conflicts from additional cards in the *VM600 Functional Safety* manual for further information.

---

## 6.5 Managing AMC8 cards (card overview page)

If an AMC8 card is selected from the configuration tree structure, a overview page for that card is displayed in the VM600 MPS1 Configuration Editor main window. A typical example is shown in Figure 6-12.

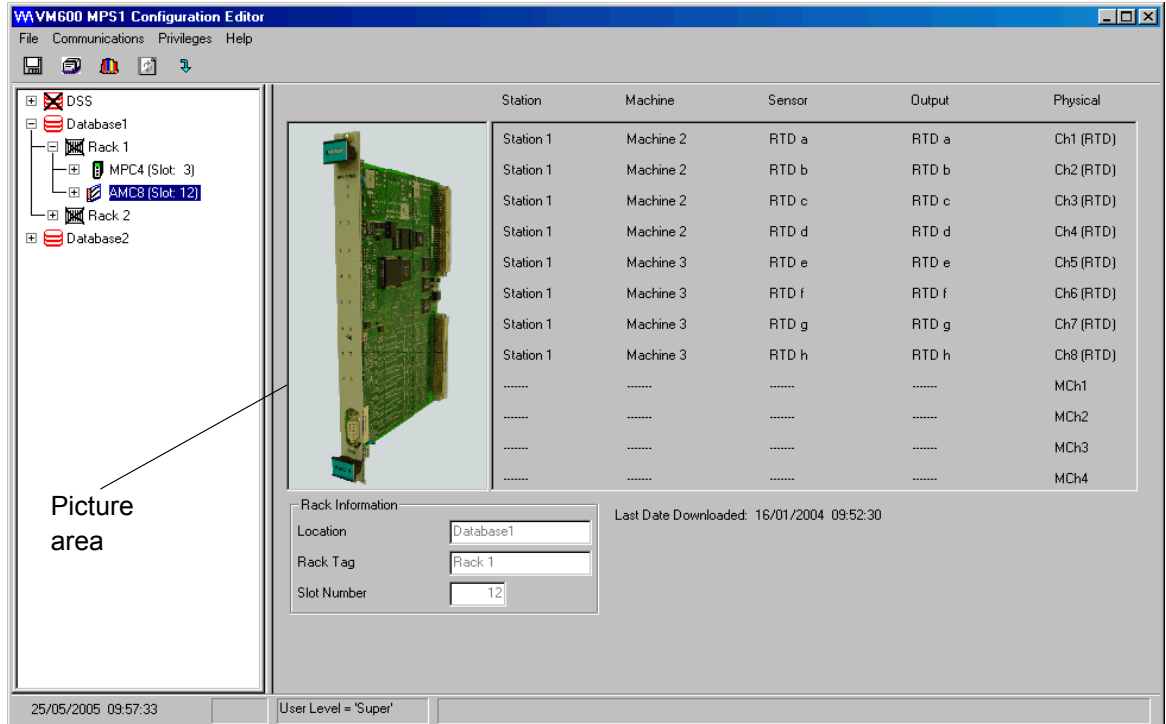

**Figure 6-12:** VM600 MPS1 Configuration Editor main Window at AMC8 card level (card overview page)

The **Rack Information** part of the window contains three non-editable fields:

- Location**                      Indicates which database the rack is attributed to.
- Rack Tag**                        Identifies the rack in which the AMC8 card is inserted.
- Slot Number**                    Indicates the slot of the rack in which the AMC8 card is inserted.

The **Station** and **Machine** columns are reserved for the VM600 MPS2 software package.

---

**NOTE:** Refer to the *VM600 MPS2 Configuration Software for Machinery Protection Systems* software manual for further information.

---

Some descriptive text concerning the measurement point may be found in the **Sensor** column. This text is copied from the text entered in the **Tag** field of the Input Configuration tab (**Inputs/Processing \ Channel n** branch of tree structure selected). See 12 Configuring inputs and processing functions (AMC8).

A customised picture may be placed in the picture area. See 6.6 Displaying a customised picture on the card overview page for further information.

### 6.5.1 Drop-down menus and toolbar (with an AMC8 card selected)

The contents of the drop-down menus are shown in Figure 6-13. This figure also explains the elements in the toolbar.

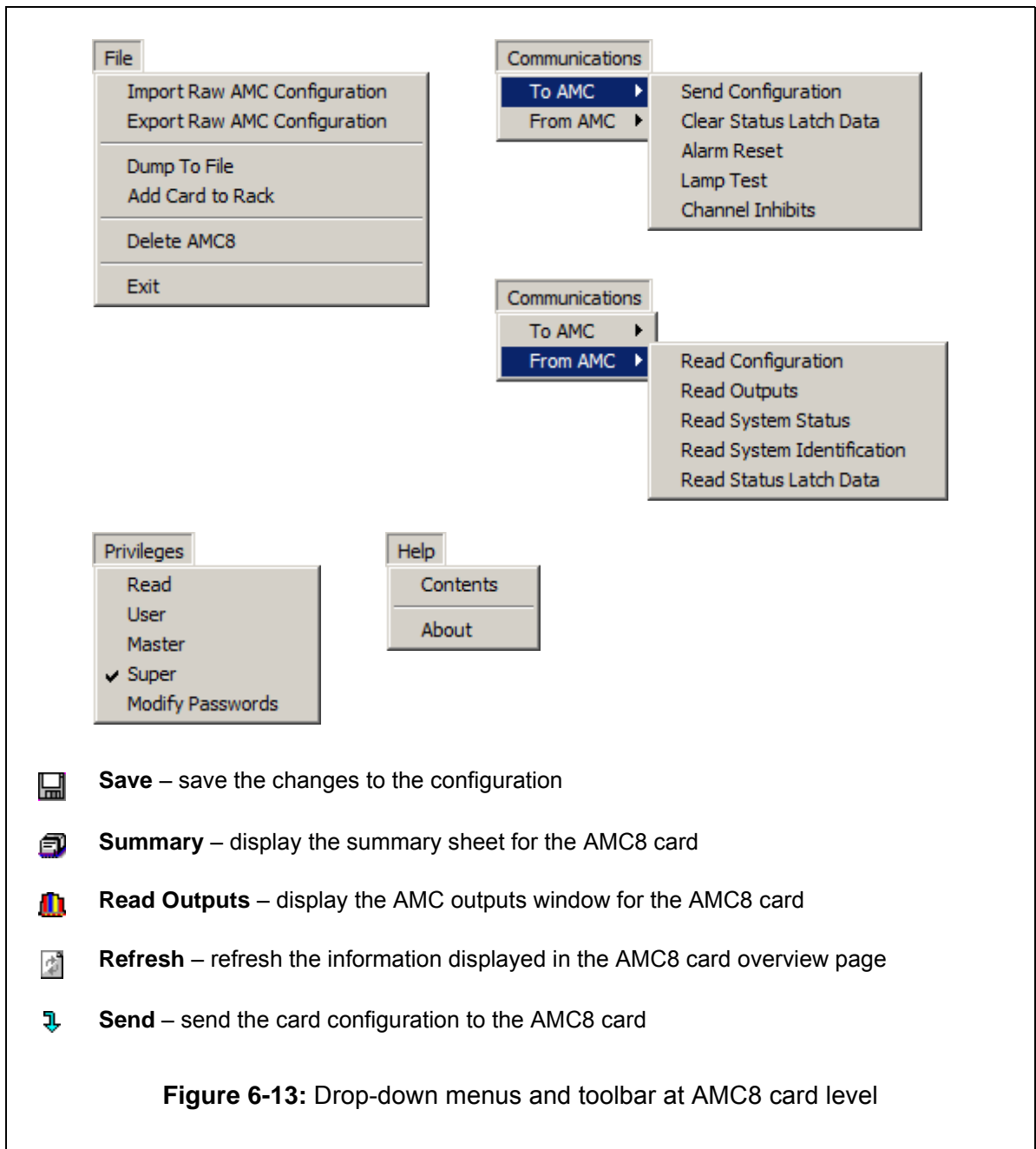

The **File** drop-down menu contains the following choices:

- Import Raw AMC Configuration** Loads an AMC8 card configuration from a pre-existing configuration file (\*.cfg).
- Export Raw AMC Configuration** Saves an AMC8 card configuration in an external configuration file (\*.cfg).

<b>Dump to File</b>	Saves an AMC8 card configuration in an external file using a comma-separated values file format (*.csv). This facilitates subsequent data processing.
<b>Add Card to Rack</b>	Adds a new AMC8 card to the rack presently selected.
<b>Delete AMC8</b>	Deletes the AMC8 card highlighted by the mouse pointer.
<b>Exit</b>	Exits (stops) the VM600 MPS1 software.

The **Communications** drop-down menu allows principally the AMC8 configuration information to be sent to the card and measured values to be read back from it. The **Communications** menu also allows channel inhibit commands to be sent to individual AMC8 input channels in order to temporarily bypass a sensor and the processing associated with it. See 15 Communications menu (AMC8) for further information on all the menu functions.

The **Privileges** drop-down menu allows one of the four privilege levels to be set and passwords to be changed. See 4.2.1 Selecting the privilege level for further information.

The **Help** drop-down menu allows the offline help concerning the VM600 MPS1 software to be accessed.

### 6.5.2 Shortcut menu (with an AMC8 card selected)

A shortcut menu is also available and is displayed when an AMC8 card-level node in the tree structure is right-clicked.

The commands available from the shortcut menu are the same as those available from the **File** drop-down menu (see 6.5.1 Drop-down menus and toolbar (with an AMC8 card selected)).

## 6.6 Displaying a customised picture on the card overview page

The picture area on the card overview page (see Figure 6-8 or Figure 6-12) displays a bitmap picture called `image_Rack-Tag_n.bmp`

where:

- *Rack-Tag* corresponds to the name entered in the **Tag** field of the rack General Information tab (see 6.3 Managing racks).
- *n* corresponds to the value entered in the **Slot Number** field. Note that *n* is an integer between 3 and 14.

Examples of typical names are:

- 1- `image_Rack_1_3` (For a card in Slot 3 of the rack having the tag "Rack 1")
- 2- `image_TESTRACK_14` (For a card in Slot 14 of the rack having the tag "TESTRACK")

---

**NOTE:** The text entered for `Rack-Tag` is case-sensitive and must exactly match the text that was entered in the **Tag** field (pay attention to spaces and capital letters).

---

If `image_Rack-Tag_n.bmp` is not found, the picture `image0.bmp` (which is delivered with the VM600 MPS1 software) is displayed instead.

To produce a customised, slot-specific picture to display in the picture area of the overview page:

- 1- Size an image to 256x266 pixels (horizontally and vertically, respectively) using a commercially available image editing package.
- 2- Transform it into bitmap format (`.bmp`).
- 3- Name the file `image_Rack-Tag_n.bmp` and place it in the `\VM600_MPS\IMAGE` sub-directory on your hard drive (this already contains the file `image0.bmp`).

The program `mps1.exe` automatically calls this image when running.

## 6.7 Displaying configuration details for cards

A summary sheet detailing the card configuration (MPC4, MPC4 SIL or AMC8) can be obtained by clicking the **Summary** button  on the toolbar at the top of the card overview page (see Figure 6-8 or Figure 6-12). A Summary Sheet window similar to that shown in Figure 6-14 appears. This provides configuration details for all channels.

The summary sheet contains **Print** and **Save** icons in a toolbar at the top of the window.

The information on the summary sheet can be saved to hard disk as a plain text file (`.txt` file name extension). This allows the summary information to be copied, printed, emailed and so on.

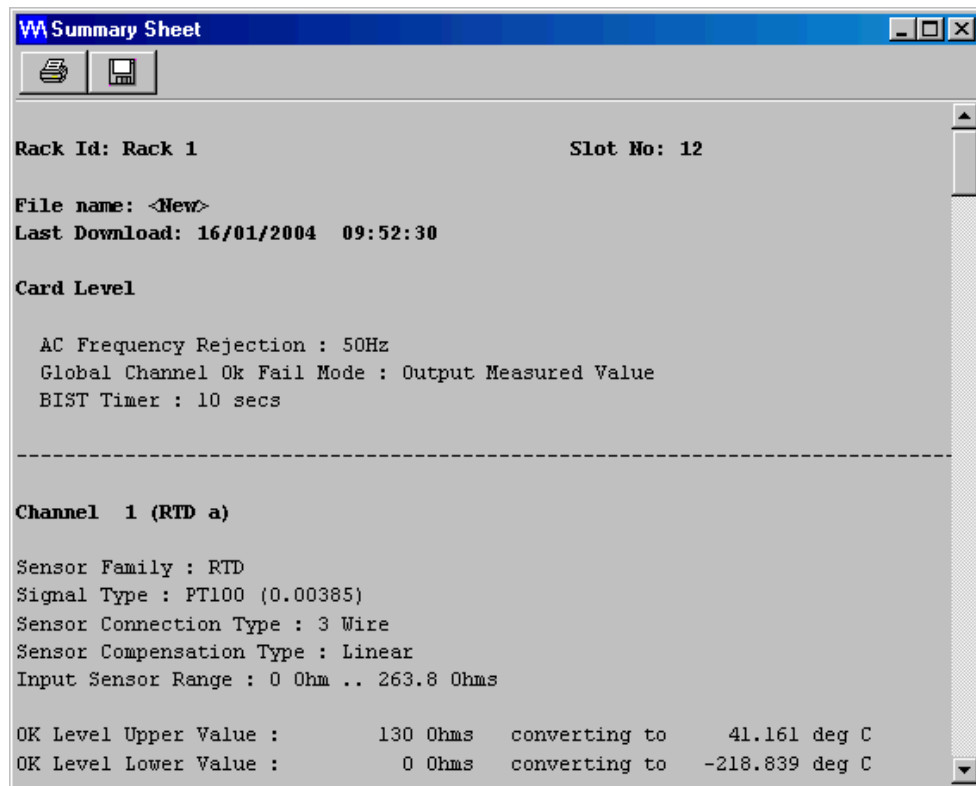

Figure 6-14: Typical Summary Sheet window

# **Part II: Configuring MPC4 and MPC4 SIL cards**

**THIS PAGE INTENTIONALLY LEFT BLANK**

## 7 INPUT CONFIGURATION (MPC4 AND MPC4 SIL)

### 7.1 Introduction

This section describes the **Inputs** branch of the configuration tree structure that is visible when an MPC4 or MPC4 SIL card is selected (see Figure 7-1). This branch allows sensor characteristics for the four measurement channels and two speed channels to be configured.

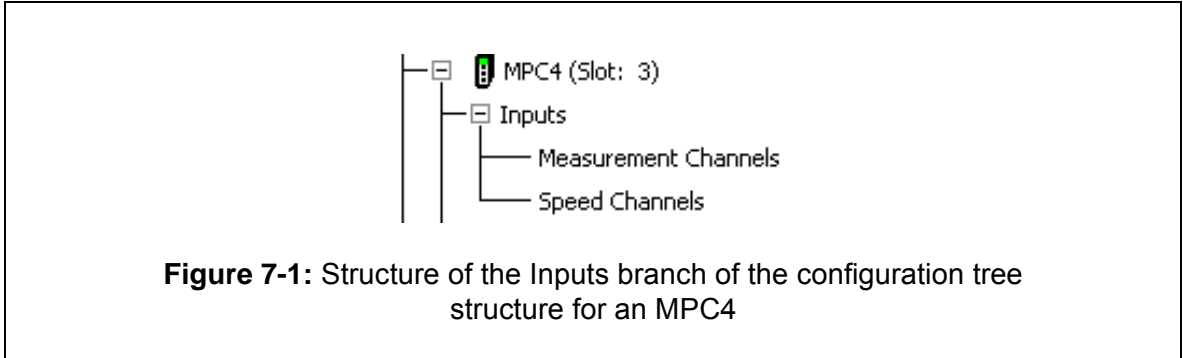

### 7.2 Configuring measurement channels

#### 7.2.1 Configuration procedure

Select the **Measurement Channels** node in the configuration tree structure to obtain a window resembling that shown in Figure 7-2. Note that the window has four tabs, allowing the configuration of Channel 1, Channel 2, Channel 3 and Channel 4. The principle is the same for each of these four channels.

To configure a given measurement channel input:

- 1- Choose the channel you want to configure (1 to 4) by clicking the appropriate tab at the top of the window.
- 2- Define the type of front-end equipment used by selecting the sensor family, the sensor type and the conditioner type:
  - The **Sensor Family** field indicates the type of signal to acquire:

<b>(AC) Dynamic Input</b>	For absolute bearing vibration, dynamic pressure measurements and so on.
<b>(DC) Quasi-Static Input</b>	For process data, position, expansion measurements and so on.
<b>(ADC) Relative Vibration</b>	For measurements of signals having a mixture of AC and DC components, for example, as provided by proximity probes (used to measure relative shaft vibration and shaft position).

- Choose the sensor from the **Sensor Type** list.

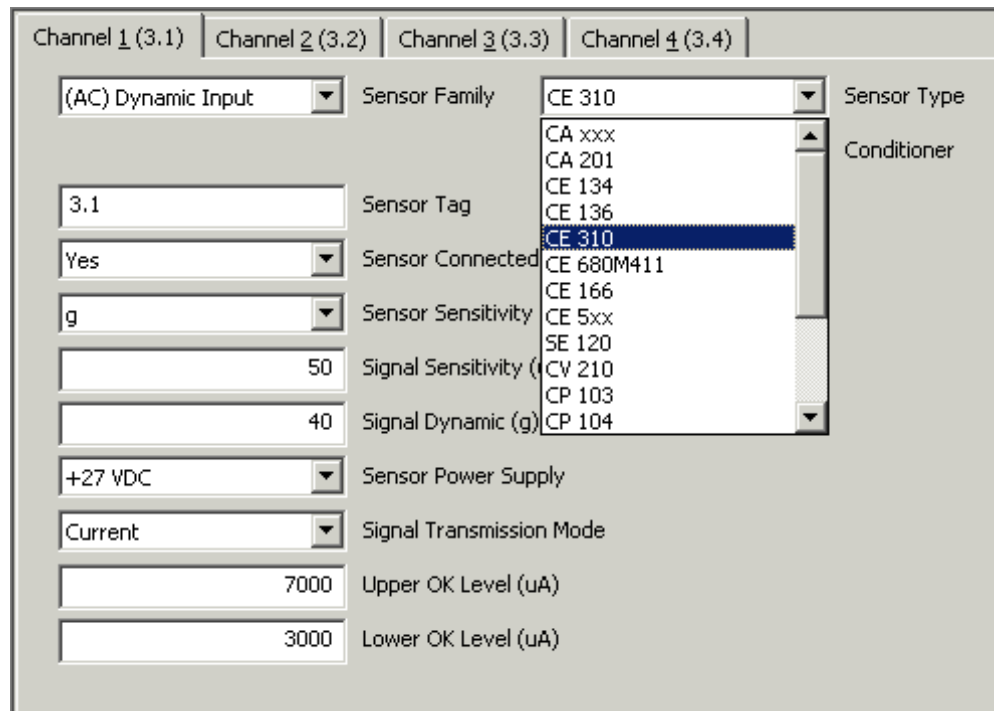

**Figure 7-2:** Window for configuration of measurement channel inputs

- Choose the conditioner from the **Conditioner** list.

The VM600 MPS1 software automatically sets up certain fields on the tab.

To ensure measurement accuracy, enter the exact **Signal Sensitivity** value according to the Vibro-Meter test certificate, from Meggitt Sensing Systems.

---

**NOTE:** If you are not using a Meggitt Sensing Systems’ Vibro-Meter front-end, choose the **Generic (non VibroMeter)** option from the **Sensor Family** menu and enter the specifications manually. Alternatively, select an equivalent front-end from the list of Meggitt Sensing Systems’ Vibro-Meter devices.

---

- 3- Enter the sensor tag and set the **Sensor Connected** field to “Yes”.
- 4- Click the **Save** icon on the toolbar to save the configuration in memory.

### 7.2.2 Additional information on fields

The operator should find most of the field labels self-explanatory. However, the following explanations are given here for further information.

<b>Sensor Tag</b>	<p>This field allows a tag to be entered to facilitate recognition of the sensor.</p> <p>The tag is automatically copied to certain other windows (for example, it is visible in the <b>Signal I/P</b> field of the Function tab when the Processing branch of the tree structure is selected).</p> <p>Default tags are applied if the user does not enter any himself. These have the form x.y where x is the card's slot number and y is the channel identifier.</p>
<b>Sensor Connected</b>	Should be set to <b>Yes</b> for normal operation.
<b>Signal Dynamic</b>	<p>This corresponds to the absolute value of the dynamic range to be measured.</p> <p>The VM600 MPS1 software provides a default value for the dynamic range, but if the actual value for a given application is known to be much lower, then this value should be entered here.</p>
<b>Sensor Power Supply</b>	<p>This field is set up automatically when Meggitt Sensing Systems' Vibro-Meter sensors and conditioners are chosen in the <b>Sensor Type</b> and <b>Conditioner</b> fields. It should only be configured manually when the <b>Sensor Family</b> field is set to <b>Generic</b> (for non Vibro-Meter devices).</p> <p>Refer to the <i>VM600 Machinery Protection System (MPS)</i> hardware manual for further information.</p>
<b>Signal Transmission Mode</b>	<p>This field is set up automatically when Meggitt Sensing Systems' Vibro-Meter sensors and conditioners are chosen in the <b>Sensor Type</b> and <b>Conditioner</b> fields. It should only be configured manually when the <b>Sensor Family</b> field is set to <b>Generic</b> (for non Vibro-Meter devices).</p> <p>Refer to the <i>VM600 Machinery Protection System (MPS)</i> hardware manual for further information.</p>
<b>Upper OK Level, Lower OK Level</b>	<p>The OK levels are used to monitor the incoming signal for problems arising in the front end of the measuring chain. These problems can be due to, for example, a defective sensor or signal conditioner, a faulty transmission line (open or short circuit).</p> <p>The OK levels are set by default when one of the Meggitt Sensing Systems' Vibro-Meter sensors is selected.</p>

## 7.3 Configuring speed channels

### 7.3.1 Configuration procedure

Select the **Speed Channels** node in the configuration tree structure to obtain a window resembling that shown in Figure 7-3. Note that the window has two tabs, allowing the configuration of Channel 1 and Channel 2. The principle is the same for both of these channels.

To configure a given speed channel input:

- 1- Choose the channel you want to configure (1 or 2) by clicking the appropriate tab at the top of the window.
- 2- Define the type of front-end equipment used by entering successively the sensor type, the conditioner type.

The VM600 MPS1 software automatically sets up certain fields on the tab.

---

**NOTE:** If you are not using a Meggitt Sensing Systems' Vibro-Meter front-end, choose the **Generic (non Vibro-Meter)** option from the **Sensor Family** menu and enter the specifications manually. Alternatively, select an equivalent front-end from the list of Vibro-Meter devices.

---

- 3- Enter a name in the **Sensor Tag** field (or simply accept the default tag proposed by the software).
- 4- If the tacho signal is obtained via the corresponding IOC (placed directly behind the MPC4 in the rack), set the **Sensor Connected** field to "Local". If it is obtained from Tacho Bus line  $n$ , choose the appropriate option Remote Channel  $n$  (where  $n$  is a value between 1 and 6).
- 5- Choose the speed unit (Hz or RPM).  
The speed alarm and hysteresis values are communicated to the MPC4 card in hundredths of Hertz (that is, the format is xxx.xx Hz). Values entered in RPM are rounded to the nearest hundredth of Hertz.
- 6- Select either "Rising" or "Falling" in the **Edge of Detection** field.
- 7- Enter the tacho ratio. To do this, enter the decimal value of the tacho ratio multiplied by 1000 or 10000 in the **Tacho Ratio Multiplier** field and enter 1000 or 10000 in the **Tacho Ratio Divider** field.

Example: If the tacho ratio is 3.263, enter:

**Tacho Ratio Multiplier** = 3263

**Tacho Ratio Divider** = 1000

**Wheel Teeth # (Hardware Divider)** = 1.

Do not set the **Multiplier**, **Divider** or **Wheel Teeth #** fields to 0. The multiplier and divider must have a value in the range 1 to 65535. The **Wheel Teeth #** field must have a value in the range 1 to 255.

---

**NOTE:** If the tacho ratio is not "1", the signal cannot be used for a phase reference, but only for speed calculation.

---

- 8- Configure the open collector alarm outputs. The lower half of the window allows the following parameters to be set for the upper Alert level (A+) and lower Alert level (A-): the alarm level, hysteresis value, alarm delay time, whether alarm enabled/disabled, whether alarm latched/unlatched.

The signal level must be over (or under, in the case of low-level alarms) the alarm level (including the hysteresis value) for longer than the alarm delay time before an alarm is generated.

Alarm Configuration Initialization					
	Level (Hz)	Hysteresis (Hz)	Delay (s)	Enable	Latch
Alert + High	55.00	1.00	5.0	<input checked="" type="checkbox"/>	<input checked="" type="checkbox"/>
Alert - Low	0.00	0.00	0.0	<input type="checkbox"/>	<input type="checkbox"/>

Figure 7-3: Window for configuration of speed channel inputs

**NOTE:** The range of alarm delay values supported by the speed channels of an MPC4 card is 0 to 60 seconds with a resolution of 0.1 second (100 milliseconds). Correct operation cannot be guaranteed if a value outside the supported range of alarm delay values is configured.

### 7.3.2 Additional information on fields

The operator should find most of the field labels self-explanatory. However, the following explanations are given here for further information.

<b>Sensor Tag</b>	<p>This field allows a tag to be entered to facilitate recognition of the sensor. The tag is automatically copied to certain other windows, for example, it is visible in the <b>Point</b> column of the MPC4 card overview page (see 6.4 Managing MPC4 and MPC4 SIL cards (card overview page)).</p> <p>Default tags are applied if the user does not enter any himself. These have the form x.y where x is the card's slot number and y is the channel identifier.</p>
<b>Sensor Connected</b>	Should be set to Yes for normal operation.
<b>Signal Transmission Mode</b>	<p>This field is set up automatically when Meggitt Sensing Systems' Vibro-Meter sensors and conditioners are chosen in the <b>Sensor Type</b> and <b>Conditioner</b> fields. It should only be configured manually when the <b>Sensor Family</b> field is set to "Generic" (for non Vibro-Meter devices).</p> <p>Refer to the <i>VM600 Machinery Protection System (MPS)</i> hardware manual for further information.</p>
<b>Upper OK Level, Lower OK Level</b>	<p>The OK levels are used to monitor the incoming signal for problems arising in the front end of the measuring chain. These problems can be due to, for example, a defective sensor or signal conditioner, a faulty transmission line (open or short circuit).</p> <p>The OK levels are set by default when one of the Meggitt Sensing Systems' Vibro-Meter sensors is selected.</p>
<b>Tachometer Output</b>	Allows the user to route the speed signal onto one of the six Tacho Bus lines.
<b>Wheel Teeth #</b>	Number of "marks" (teeth or notches) on the circumference of the wheel used for measuring the rotational speed.

## 7.4 Copying card configurations

When configuring MPC4 and MPC4 SIL cards, copy operations are supported that allow the Inputs or Processings and Alarms already configured for an MPC4 or MPC4 SIL card to be re-used elsewhere on the same card.

Using the copy operations for MPC4 and MPC4 SIL card configurations helps to make the management of VM600 MPS Software configurations easier. For example, the Inputs, Processing (and Alarms) could be configured for one channel of the card and then re-used as the basis for other similar channels on the same card.

The **Copy Inputs** command is available for operation with the Inputs of an MPC4 or MPC4 SIL card (Measurement channels 1 to 4 and Speed Channels 1 to 2).

The **Copy Processings and Alarms** command is available for operation with the Processing of an MPC4 or MPC4 SIL card (Processing channels 1 to 4, Dual Processing channel 1 & 2 and Dual Processing channel 3 & 4) including any alarms configured for the processing channel.

To use the copy operation commands:

- Click on an MPC4 or MPC4 SIL card level node in the configuration tree to select it, then use the **File > Copy Inputs** and **File > Copy Processings and Alarms** menu commands.  
Alternatively, right-click on an MPC4 or MPC4 SIL card level node in the configuration tree, then click **Copy Inputs** or **Copy Processings and Alarms**.
- Then use the copy dialog box that appears to select the Channel or Processing Channel to copy from and the Channel or Processing Channel to copy to.

---

**NOTE:** The copy operations for MPC4 and MPC4 SIL card configurations are limited to the same card (not between different MPC4 or MPC4 SIL cards) and work on a channel basis, that is, the configuration of a single input channel can be copied to another single input channel.

---

**THIS PAGE INTENTIONALLY LEFT BLANK**

## 8 PROCESSING CONFIGURATION (MPC4 AND MPC4 SIL)

### 8.1 Introduction

This section describes the **Processing** branch of the configuration tree structure, visible when an MPC4 or MPC4 SIL card is selected (see Figure 8-1). This branch allows each processing channel to be assigned to specific input sensors (for example, vibration, dynamic pressure, speed). All aspects of the signal processing are defined here, including the processing function (for example, Broad Band Absolute Bearing Vibration or Relative Shaft Vibration), filtering characteristics, measurement units and alarm parameters.

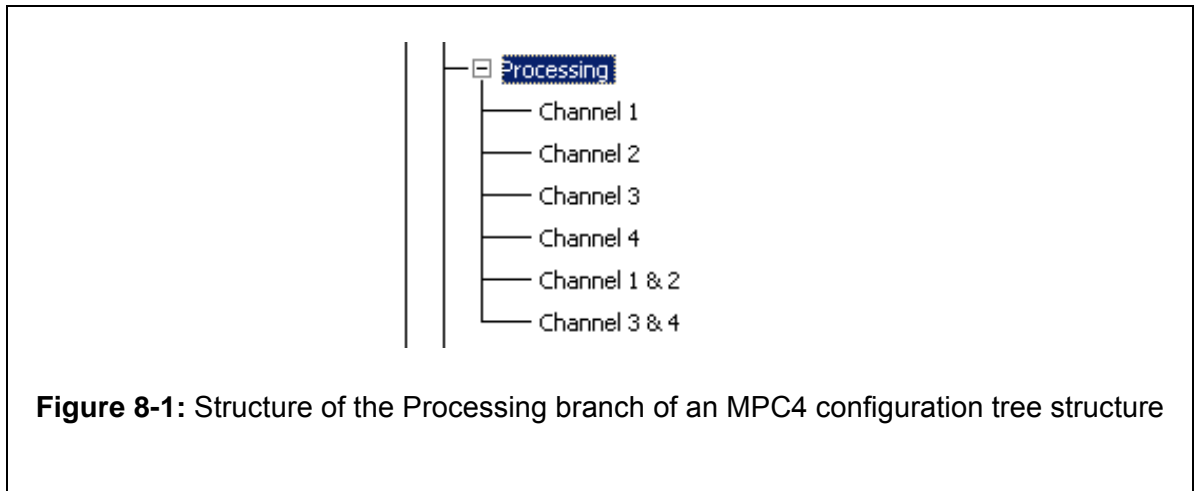

**NOTE:** The MPC4 machinery protection card is available in different versions, including a standard version, a separate circuits version and a safety (SIL) version. The MPC4 SIL (safety MPC4 card) does not provide all of the signal processing capabilities of the standard and the separate circuits versions of the MPC4. See 8.3 Additional information on processing functions.

For an improved understanding of the possibilities offered, it is recommended to refer to the description of the various processing functions given in the *VM600 Machinery Protection System (MPS) hardware manual*.

### 8.2 Configuring a processing channel

To configure a given processing channel:

- 1- Select the channel you wish to configure from the **Processing** branch of the configuration tree structure. This can be a single channel (Channel 1, Channel 2, Channel 3, Channel 4) or a dual channel (Channels 1&2, Channels 3&4).

In all cases, a window resembling that shown in Figure 8-2 appears. Note that the window has two or three tabs, depending on whether a single or dual channel is chosen:

- **Function:**

Used to attribute an input channel (vibration sensor / speed sensor) to the processing channel.

Also used to configure the processing function and other processing parameters (for example, filter characteristics).

- **Processed Output (1/2):**

Used to configure the measurement units, rectifier characteristics and so on.

Alarm parameters and adaptive monitoring parameters are also configured here. For single channels, two independent outputs (Output 1 and Output 2) can be configured using the Processed Output 1 and Processed Output 2 tabs, respectively.

For dual channels, one output (Output 1) can be configured using the Processed Output 1 tab.

2- Select the **Function** tab. A window resembling that shown in Figure 8-2 appears.

3- Choose the desired processing function from the list available in the **Function** field.

For single channel processing, this list includes:

- (BBAB) Broad Band Absolute Bearing Vibration
- (NB) Narrow Band (Tracking) Vibration
- (RS) Relative Shaft Vibration
- (PS) Position
- (EC) Eccentricity
- (HE) Absolute Housing Expansion
- (SEP) Relative Shaft Expansion with Pendulum
- (BBP) Broad Band Pressure
- (QSP) Quasi-Static Pressure
- (QST) Quasi-Static Temperature
- (NBFS) Narrow Band Fixed Frequency.

For dual channel processing, this list includes:

- (SMAX) Smax
- (DHE) Differential Housing Expansion
- (RST) Relative Shaft Expansion (Shaft taper)
- (RSC) Relative Shaft Expansion (Shaft collar)
- (DQSP) Delta Quasi-Static Pressure
- (DQST) Delta Quasi-Static Temperature
- (AS) Absolute Shaft Vibration
- (DMF) Dual Mathematical Function.

---

**NOTE:** More detailed information on these functions is given in 8.3 Additional information on processing functions

---

4- Choose the input sensor you want to associate with the processing channel.

To do this, select an option from the **Signal Input**, **Speed Input** or **One Per Rev** fields, as appropriate. Some these fields are unavailable (dimmed) depending on the function chosen.

5- Configure the other fields on the Function tab.

The fields visible on the tab depend on the processing function chosen. See 8.3 Additional information on processing functions for further information.

6- Select the **Processed Output 1** or **Processed Output 2** tab, as appropriate. These two tabs each give access to another three tabs named **General**, **Alarms** and **Adaptive**

**Monitoring.** If the **General** tab is selected, a window resembling that shown in Figure 8-3 appears.

**NOTE:** Further information on the **Processed Output \ General** tab is given in 8.4 Parameter fields found on the “Processed Output” tabs

- 7- From the **Processed Output** tab, select the **Alarms** tab to set up alarm parameters.

**NOTE:** Further information on the **Processed Output \ Alarms** tab is given in 8.5 Configuring alarms

- 8- From the **Processed Output** tab, select the **Adaptive Monitoring** tab to set up **Direct Trip Multiply** and **Adaptive Monitoring** parameters.

**NOTE:** Further information on the **Processed Output \ Adaptive Monitoring** tab is given in 8.6 Adaptive monitoring and direct trip multiply

The screenshot shows a software configuration window with the following elements:

- At the top, there are tabs for "Function", "Processed Output 1", and "Processed Output 2".
- A dropdown menu is set to "(BBAB) Broad Band Absolute Bearing Vibration" with a "Function" label.
- Below this, there are three input fields: "Sensor 1 (3.1)" labeled "Signal I/P", "Not Used" labeled "Speed I/P", and "Not Used" labeled "One Per Rev". A note states: "Note: Required for phase information".
- A section titled "Broad Band Processing Function Configuration Data Registers" contains:
  - A "Filter type" dropdown set to "Band pass".
  - A trapezoidal filter response diagram with the following parameters:
    - High Pass Cut-Off Frequency: 45.0 Hertz
    - Low Pass Cut-Off Frequency: 380.0 Hertz
    - Slope: 48 dB/Oct
    - Min. slope: 48 dB/Oct

**Figure 8-2:** Typical window when the “Function” tab is selected (example for Broad Band Absolute Bearing Vibration processing function)

Field	Value
Tag	3.1.1
Output Used	Yes
Engineering Unit	mm/s
Rectifier Function	RMS
Rectifier Resp. Time (ms)	400
Full Scale Deflection	100

**Figure 8-3:** Typical window when the “Processed Output” tab is selected (example for Broad Band Absolute Bearing Vibration processing function)

### 8.3 Additional information on processing functions

The MPC4 machinery protection card is available in different versions, including a standard version, a separate circuits version and a safety (SIL) version. The MPC4 SIL (safety MPC4 card) does not provide all of the signal processing capabilities of the standard and the separate circuits versions of the MPC4.

For example, the MPC4 SIL card does not support the speed/phase reference (tachometer) input channels, the Narrow Band (Tracking Vibration and  $S_{max}$  processing functions, and it does not support danger bypass (DB) and trip multiply (TM) functions.

---

**NOTE:** Refer to the *VM600 Machinery Protection System (MPS) hardware manual* and the *VM600 Functional Safety manual* for further information.

---

### 8.3.1 Broad band absolute bearing vibration

This processing function performs low-pass, band-pass and high-pass filtering. The cut-off frequencies can be chosen in the range 0.1 to 10 kHz. The frequencies are defined at the -0.1 dB cut-off point.

The ratio between the high and low cut-off frequencies can be set to a value of up to 500 if there is no integration, or up to 100 with integration.

---

**NOTE:** The MPC4 card has two on-board integrators: one hardware and one firmware (at DSP level) There are therefore three possible integration configurations:

1. No integrator
2. One integration
3. Two integrations.

The choice is made using the **Sensor Input Unit** and **Engineering unit** (processing output) fields:

1. **Sensor Input Unit** = "g" and **Engineering unit** = "g" => No integrator.
  2. **Sensor Input Unit** = "g" and **Engineering unit** = "mm/s" => 1 integration (HW).
  3. **Sensor Input Unit** = "g" and **Engineering unit** = "µm" => 2 integrations (HW and FW).
- 

The filter slopes can be chosen in the range 6 to 60 dB/oct. The slopes for the high-pass and low-pass filters may be set differently.

---

**NOTE:** Improved filter characteristics may be achieved for specific applications. Contact your Meggitt Sensing Systems representative for further information.

---

The Typical Function and Processed Output windows are shown in Figure 8-2 and Figure 8-3 respectively.

### 8.3.2 Narrow band (tracking) vibration

This processing function filters the signal with a constant-Q filter (Q=28) around the selected harmonic.

It is necessary to define both the speed input and the phase reference input. This is done using the **Speed I/P** and **One Per Rev** fields, respectively (see Figure 8-4). In order to obtain meaningful phase information, the phase reference must provide only one pulse per revolution.

The tracking function follows speed variations in real time. The harmonic to be processed (1X, 2X, 3X, 4X, 1/2 X, 1/3 X) can be selected in the **Harmonic to Process** field.

The calculation is restricted to a frequency band defined by the **Tracking Frequency Lower Limit** and **Tracking Frequency Upper Limit** fields. Tracking is not be performed outside this band.

The **Sensor Original Position** field allows the phase to be compensated for a given mounting angle (possible values are 0 to 359°). This angle is subtracted from the measurement.

For this processing function, the two **Processed Output** tabs are replaced by the **Amplitude** and **Phase** tabs.

Typical Function, Amplitude and Phase tabs are shown in Figure 8-4 and Figure 8-5.

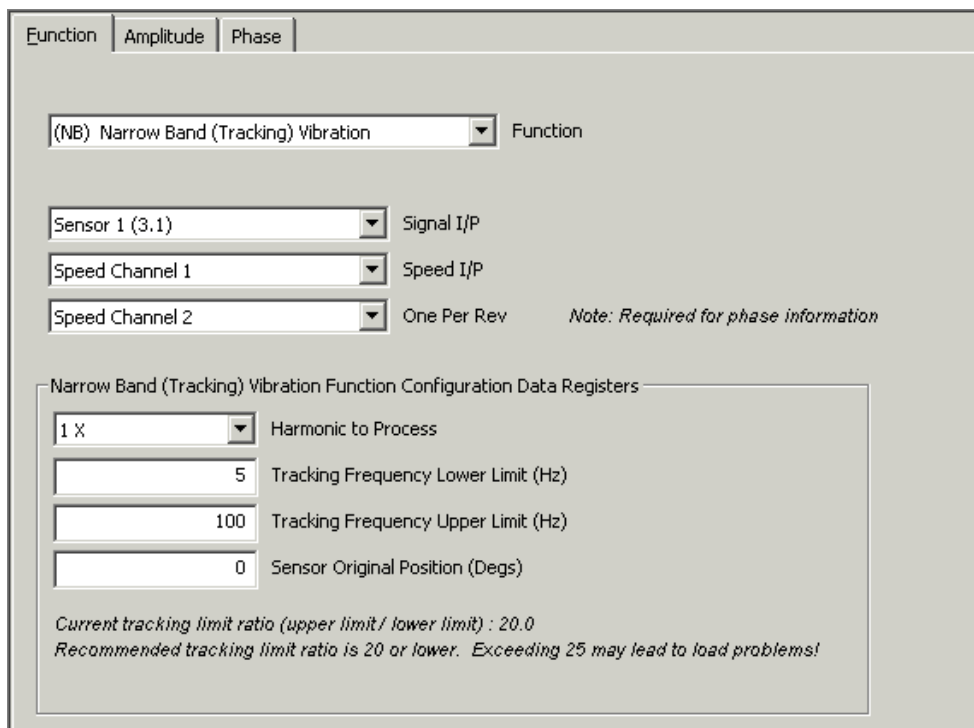

**Figure 8-4:** Typical “Function” window for Narrow Band (Tracking) Vibration processing function

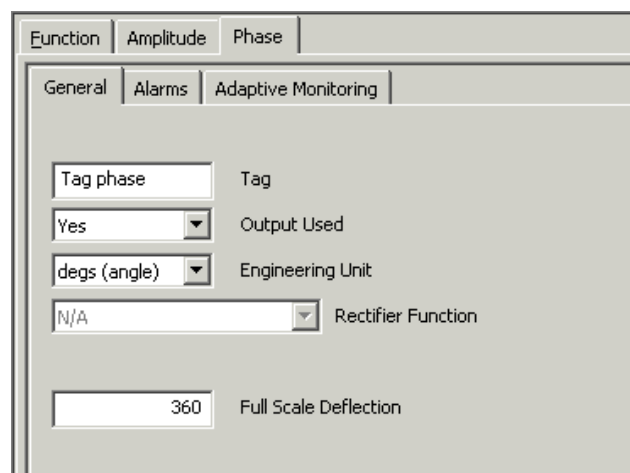
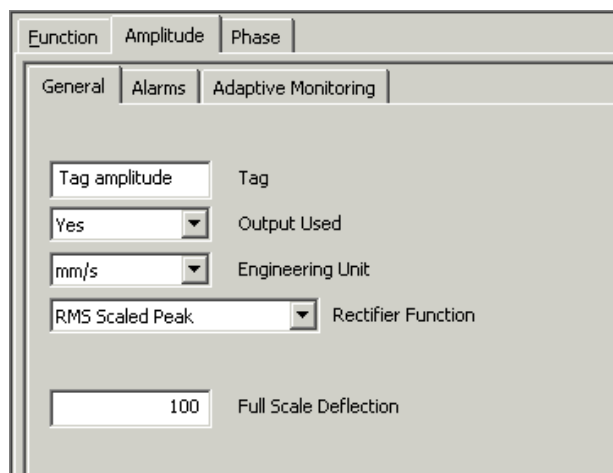

**Figure 8-5:** Typical “Amplitude” and “Phase” windows for Narrow Band (Tracking) Vibration processing function

### 8.3.3 Relative shaft vibration

This function processes the AC (0.1 to 10 kHz) and DC (0 to 1 Hz) components of a signal coming from an “ADC” type probe (for example, a proximity probe). It can provide vibration and gap values from a single input channel. The rectified vibration data is routed to the first output, and the gap value to the second output.

If phase information is required, a speed channel must be named in the **One Per Rev** field.

The value entered in the **Proximity Probe Initial Gap** field is subtracted from the measured value. The resulting gap measurements are centred around this initial (mean) position.

The **Bandwidth** field allows high frequencies to be filtered out if spurious spikes are present in the raw signal. This bandwidth should be set to a value exceeding 20 times the rotational frequency, so that the signal waveform is not disturbed by the filter. For example, if the rotational speed is 3000 RPM, corresponding to 50 Hz, a bandwidth in excess of 1000 Hz should be chosen. The maximum bandwidth that can be set is 10 kHz.

For this processing function, the Processed Output 1 and Processed Output 2 tabs are replaced by the Measurement and Gap tabs, respectively.

Typical Function, Measurement and Gap tabs are shown in Figure 8-6 and Figure 8-7.

The screenshot shows a software interface with three tabs: 'Function', 'Measurement', and 'Gap'. The 'Function' tab is active. It contains the following elements:

- A dropdown menu for 'Function' set to '(R5) Relative Shaft Vibration'.
- A dropdown menu for 'Signal I/P' set to 'Sensor 1 (3.1)'.
- A dropdown menu for 'Speed I/P' set to 'Not Used'.
- A dropdown menu for 'One Per Rev' set to 'Not Used', with a note: *Note: Required for phase information*.
- A section titled 'Relative Shaft Vibration (R5) Function Configuration Data Registers' containing two input fields:
  - 'Proximity Probe Initial Gap (mm)' with the value '1.270'.
  - 'Bandwidth (Hz)' with the value '5000'.

**Figure 8-6:** Typical “Function” tab for Relative Shaft Vibration processing function

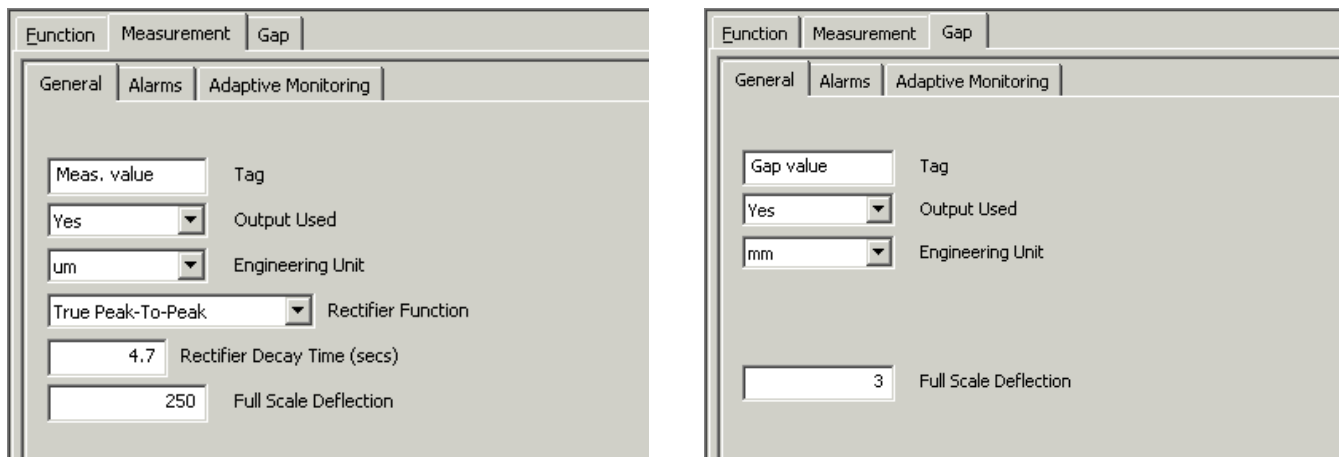

**Figure 8-7:** Typical “Measurement” and “Gap” windows for Relative Shaft Vibration processing function

### 8.3.4 Position

This function processes DC signals representing, for example, the position of a shaft in a thrust bearing or the expansion of a machine element due to thermal effects.

Choose the unit in which you wish to express the position by setting the **Engineering Unit** field on the Processed Output tab. (The unit can be  $\mu\text{m}$ , mm, mils or user-defined.)

The value in the **Sensor Offset** field ( $\mu\text{A}$  or mV) is first subtracted from the measured value.

Next, the value in the **Proximity Probe Initial Gap** field is subtracted from the measured value after conversion to the physical unit. The initial gap is expressed as an integer value in the selected engineering unit. Select microns ( $\mu\text{m}$ ) for greatest accuracy.

If you want to reverse the sign of the measurement, select the **Sensor Inverted** button.

Otherwise, if you want a direct measurement (positive direction for positive voltage or current), select the **Direct Sensor** button.

The Position processing function can be used in conjunction with the dual channel mode to measure:

- Differential housing expansion (DHE)
- Relative shaft expansion (RSC) with collar
- Relative shaft expansion (RST) with single or double shaft taper.

If this is to be done, both single channels making up the dual channel pair (that is, Channel 1 + Channel 2, or Channel 3 + Channel 4) must be configured for Position processing.

Typical Function and Processed Output windows are shown in Figure 8-8 and Figure 8-9 respectively.

**Example set-up**

An AE 119 transducer provides an output of 4 to 20 mA.

If a direct positive measurement is required, enter 4000  $\mu$ A in the **Sensor Offset** field.

If you want a reversed output from the same transducer, select the **Sensor Inverted** button and enter 20000  $\mu$ A in the **Sensor Offset** field.

Enter a value in the **Proximity Probe Initial Gap** field corresponding to the gap when the machine is cold (this is often around 10 mm).

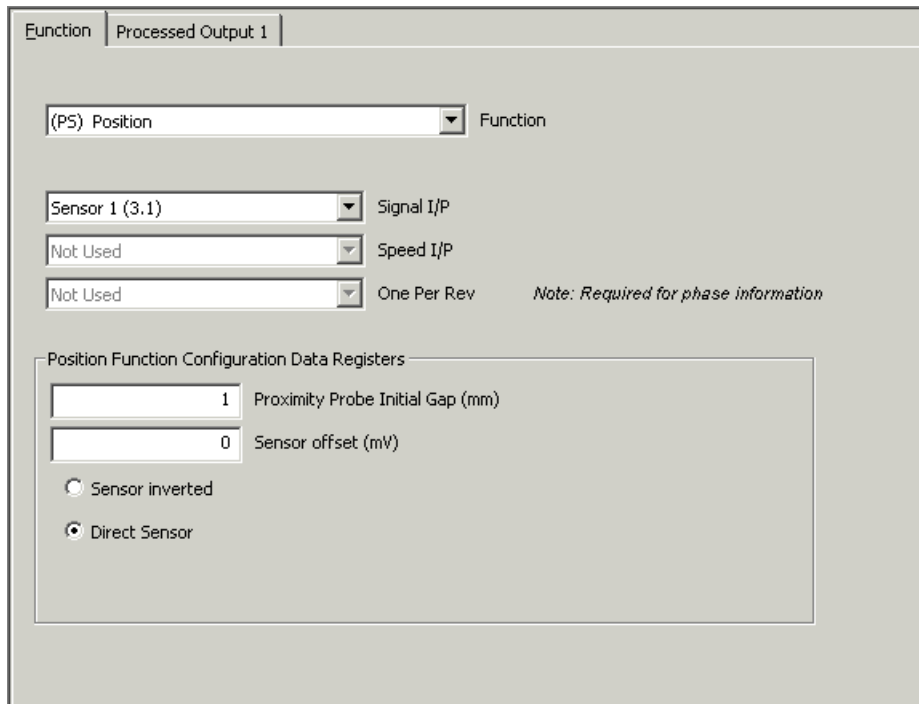

**Figure 8-8:** Typical “Function” tab for Position processing function

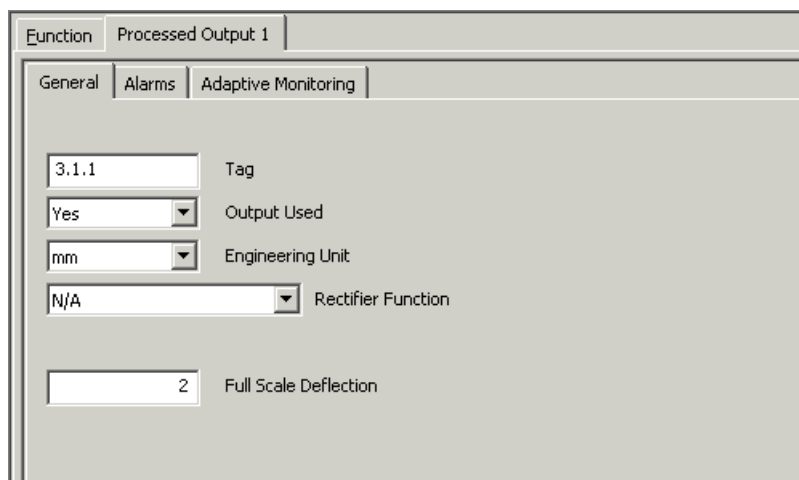

**Figure 8-9:** Typical “Processed Output” tab for Position processing function

### 8.3.5 Eccentricity

This processing function outputs the eccentricity of a shaft measured by a proximity probe. The function extracts the peak-to-peak level at low frequency.

The upper cut-off frequency (defined by a low-pass filter) is set to 5 Hz by default. However, this can be configured to a value between 5 and 10 Hz if desired using the **Low Pass Cut-Off Frequency** field. The filter slope is also configurable in the range 6 to 60 dB/oct.

Peak-to-Peak and Peak-to-Peak per Revolution rectifiers are available. In the case of Peak-to-Peak per Revolution, the minimum and maximum values are recorded for each revolution of the shaft. This option is recommended.

When Peak-to-Peak rectification is chosen, the minimum frequency considered is 2 Hz (corresponding to a rotational speed of 120 RPM).

When Peak-to-Peak per Revolution rectification is chosen, frequencies down to DC (0 Hz) are considered.

If strong harmonics are seen on the signal, adjust the upper cut-off frequency (using the **Low Pass Cut-Off Frequency** field) in order to filter out these unwanted components and keep only the first orders.

Typical Function and Processed Output tabs are shown in Figure 8-10 and Figure 8-11 respectively.

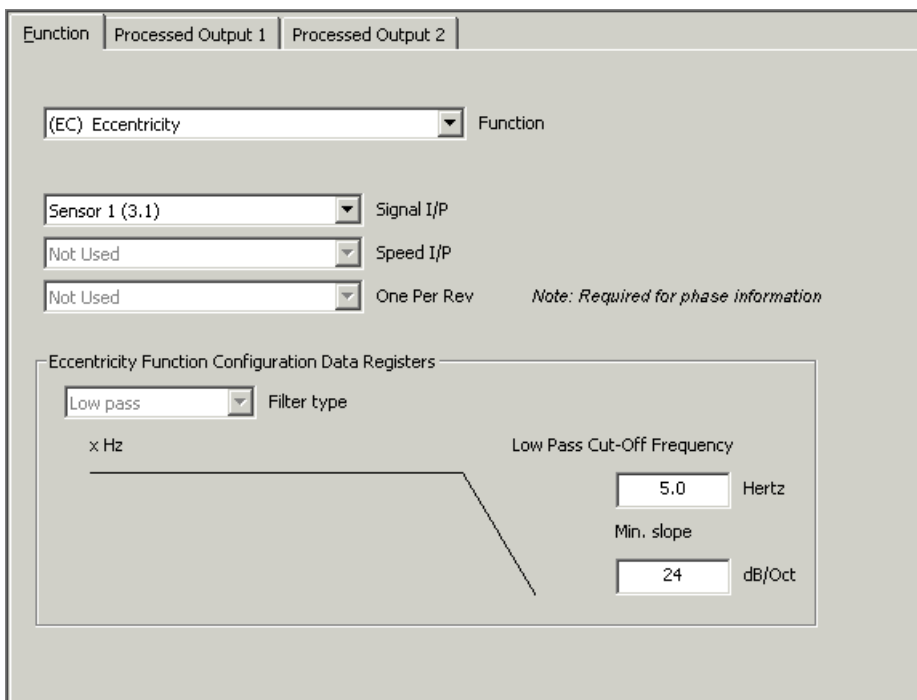
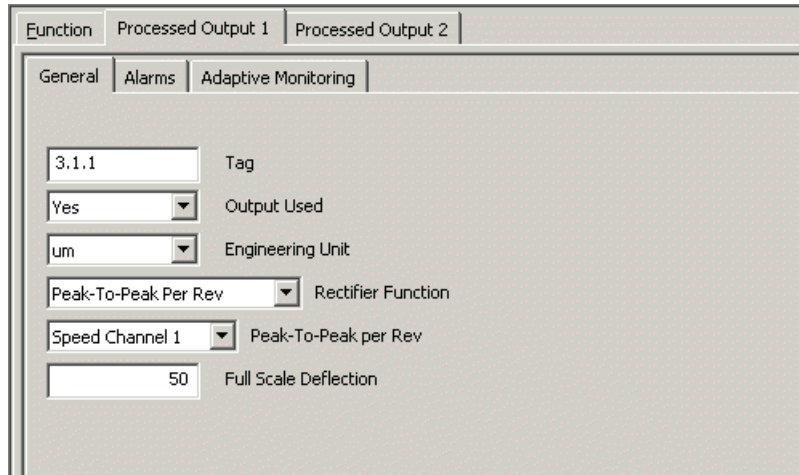

Figure 8-10: Typical "Function" tab for Eccentricity processing function



**Figure 8-11:** Typical “Processed Output” tab for Eccentricity processing function

### 8.3.6 Absolute housing expansion

This processing function is similar to the Position processing function.

---

**NOTE:** See 8.3.4 Position for further information on fields that can be configured. An example set-up is also provided.

---

Typical Function and Processed Output tabs are shown in Figure 8-12 and Figure 8-13 respectively.

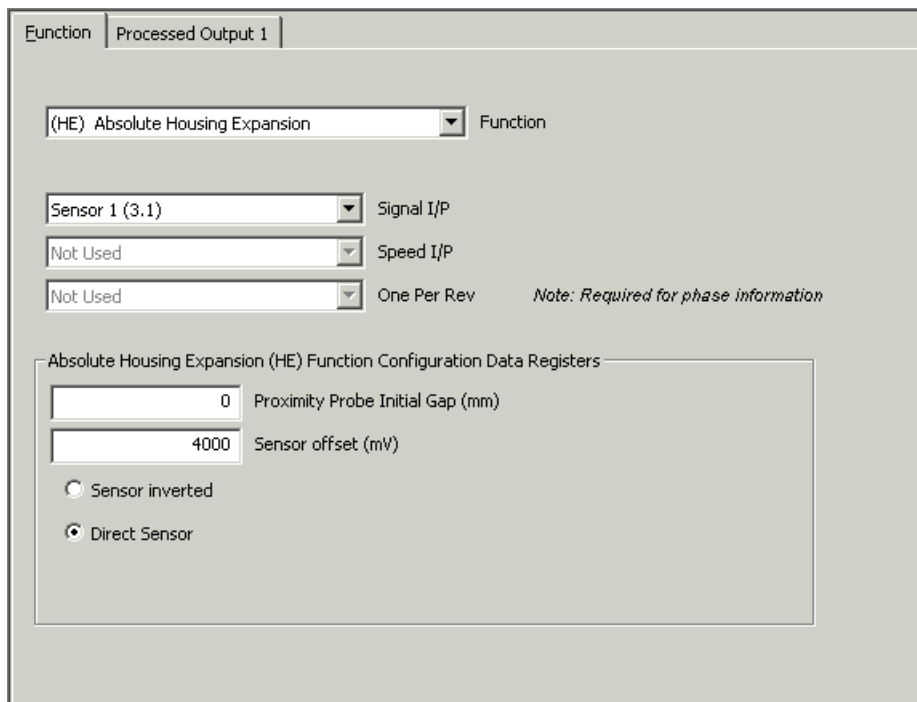

**Figure 8-12:** Typical “Function” tab for Absolute Housing Expansion processing function

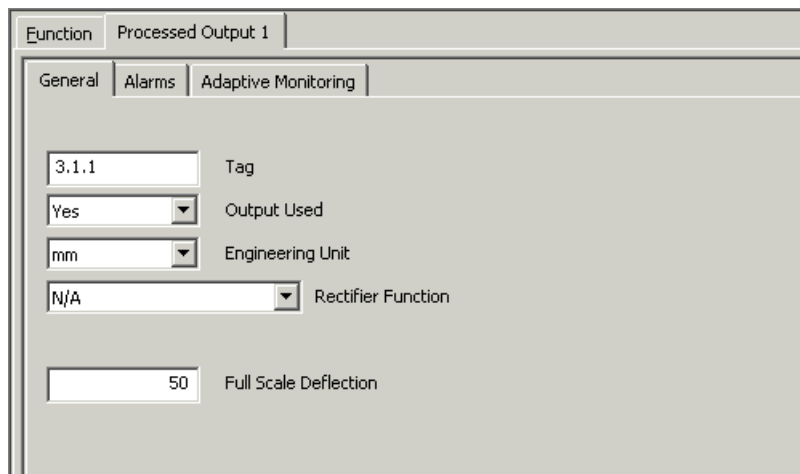

**Figure 8-13:** Typical “Processed Output” tab for Absolute Housing Expansion processing function

### 8.3.7 Relative shaft expansion with pendulum

This processing function is similar to the Position processing function.

---

**NOTE:** See 8.3.4 Position for further information on fields that can be configured. An example set-up is also provided.

---

Typical Function and Processed Output tabs are shown in Figure 8-14 and Figure 8-15 respectively.

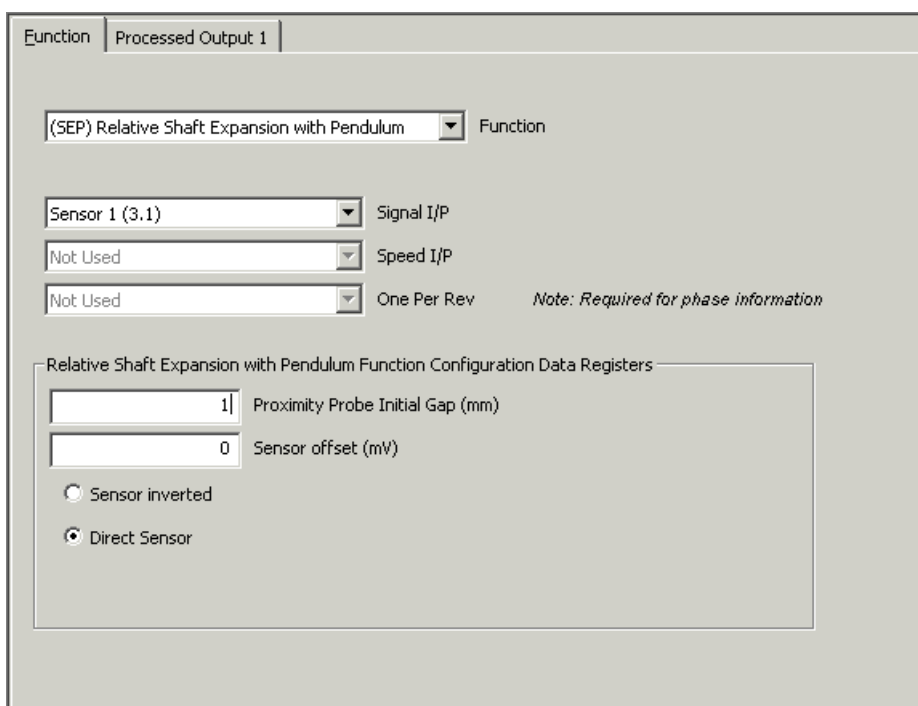

**Figure 8-14:** Typical “Function” tab for Relative Shaft Expansion with Pendulum processing function

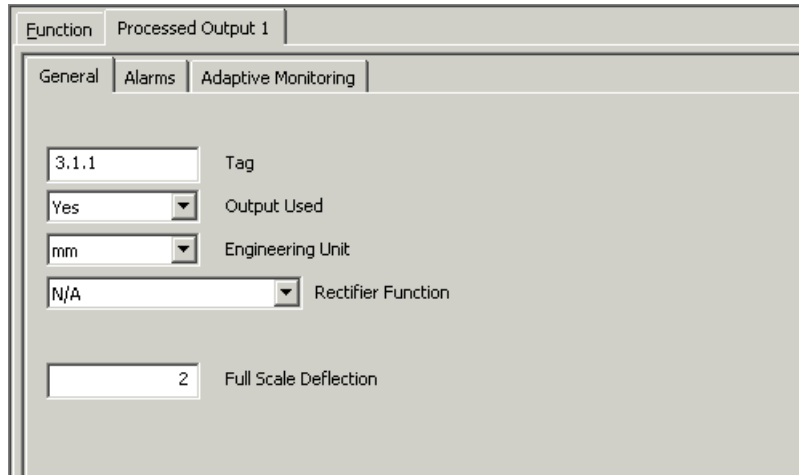

**Figure 8-15:** Typical “Processed Output” tab for Relative Shaft Expansion with Pendulum processing function

**8.3.8 Broad band pressure**

This processing function is identical to that for Broad Band Absolute Bearing Vibration processing, with the exception that a dynamic pressure probe must be selected in the **Sensor Type** field (visible when Inputs \ Measurement Channels branch of tree structure selected).

**NOTE:** See 8.3.1 Broad band absolute bearing vibration for further information on broad-band processing.

Typical Function and Processed Output tabs are shown in Figure 8-16 and Figure 8-17 respectively.

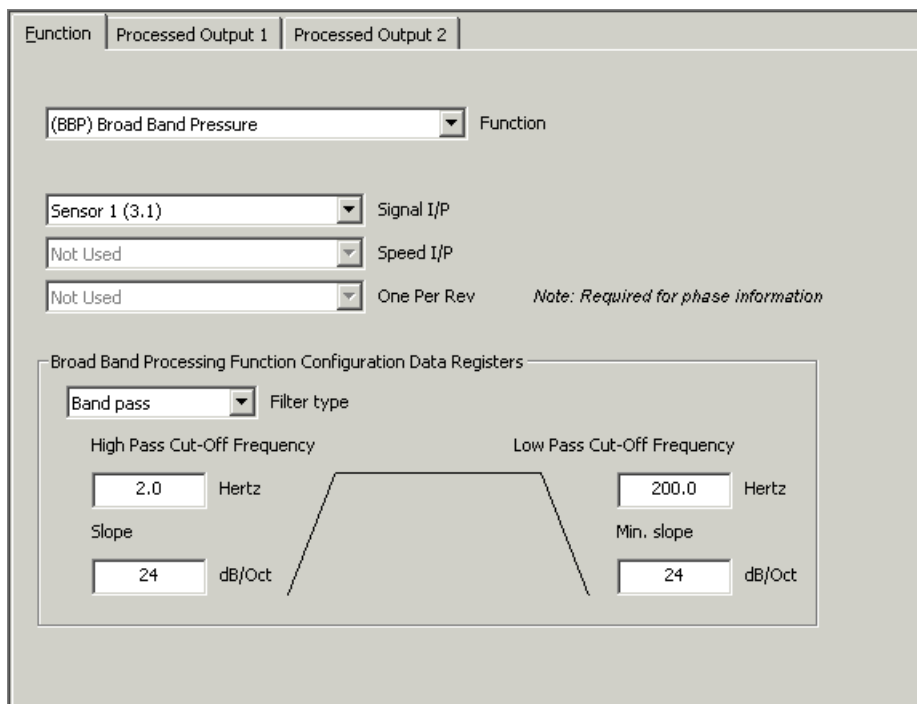

**Figure 8-16:** Typical “Function” tab for Broad Band Pressure processing function

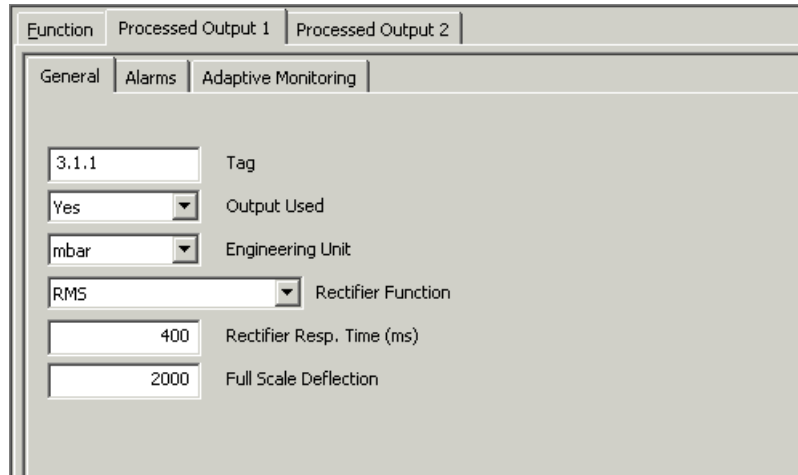

**Figure 8-17:** Typical "Processed Output" tab for Broad Band Pressure processing function

### 8.3.9 Quasi-static pressure

This processing function is similar to the Position processing function (see 8.3.4 Position), but with pressure measurement units.

A quasi-static pressure probe must first be defined. Select the Inputs \ Measurement Channels branch of the tree structure and set the following two fields as shown:

**Sensor Family** (DC) Quasi-Static Input.

**Sensor Type** DC P[bar].

Choose the unit in which you wish to express the pressure by setting the **Engineering Unit** field on the Processed Output tab (see Figure 8-19). The unit can be mbar, bar, psi, Pa or user-defined.

The value in the **Sensor Offset** field ( $\mu\text{A}$  or  $\text{mV}$ ) is first subtracted from the measured value.

Next, the value in the **Static Pressure Compensation** field is subtracted from the measured value after conversion to the physical unit. The initial (or reference) pressure is expressed as an integer value in the selected engineering unit. Select pascals (Pa) for greatest accuracy.

If you want to reverse the sign of the measurement, select the **Sensor Inverted** button.

Otherwise, if you want a direct measurement (positive pressure for positive voltage or current), select the **Direct Sensor** button.

Typical Function and Processed Output tabs are shown in Figure 8-18 and Figure 8-19 respectively.

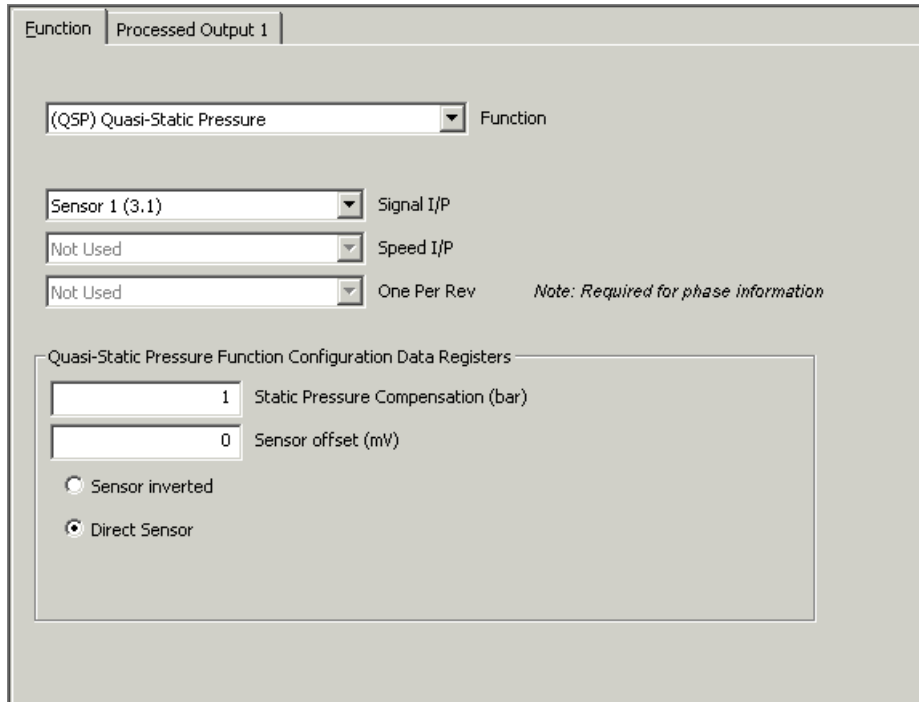

**Figure 8-18:** Typical "Function" tab for Quasi-Static Pressure processing function

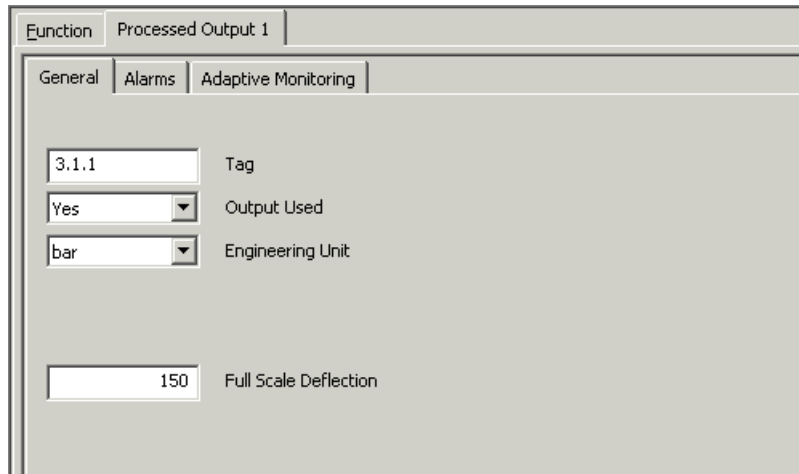

**Figure 8-19:** Typical "Processed Output" tab for Quasi-Static Pressure processing function

### 8.3.10 Quasi-static temperature

This processing function is similar to the Position processing function (see 8.3.4 Position), but with temperature measurement units.

A quasi-static temperature probe must first be defined. Select the Inputs \ Measurement Channels branch of the tree structure and set the following two fields as shown:

**Sensor Family** (DC) Quasi-Static Input.

**Sensor Type** DC T[°C].

Choose the unit in which you wish to express the temperature by setting the **Engineering Unit** field on the Processed Output tab (see Figure 8-21). The unit can be degs (C), meaning degrees Celsius, or user-defined.

The value in the **Sensor Offset** field ( $\mu$ A or mV) is first subtracted from the measured value.

Next, the value in the **Static Temperature Compensation** field is subtracted from the measured value after conversion to the physical unit. The initial (or reference) temperature is expressed as an integer value in the selected engineering unit.

If you want to reverse the sign of the measurement, select the **Sensor Inverted** button.

Otherwise, if you want a direct measurement (positive temperature for positive voltage or current), select the **Direct Sensor** button.

Typical Function and Processed Output tabs are shown in Figure 8-20 and Figure 8-21 respectively.

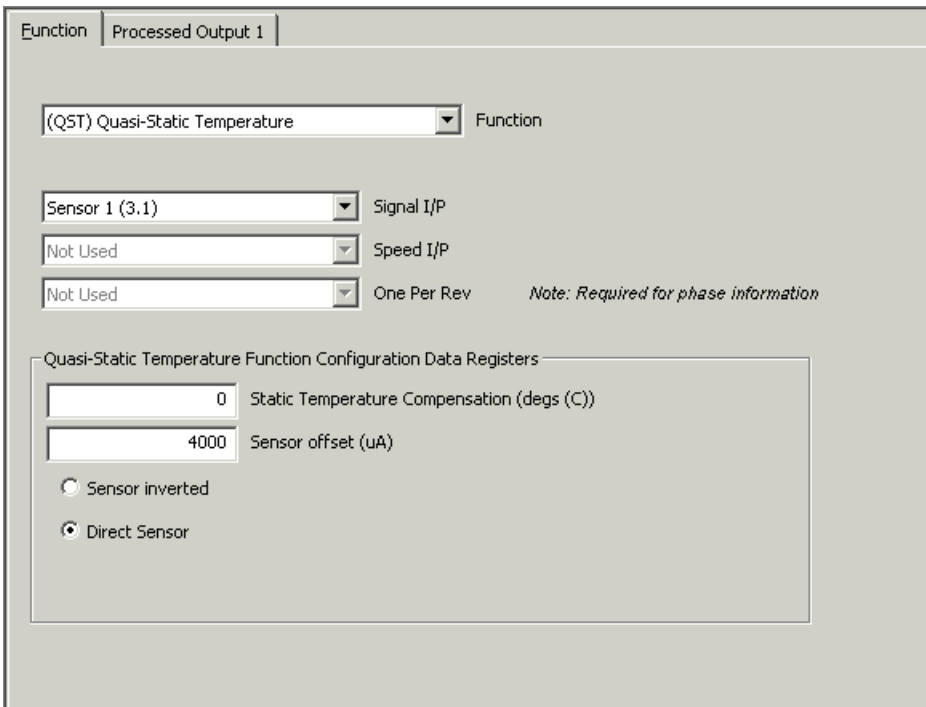

**Figure 8-20:** Typical “Function” tab for Quasi-Static Temperature processing function

Function Processed Output 1

General Alarms Adaptive Monitoring

3.1.1 Tag

Yes Output Used

degs (C) Engineering Unit

400 Full Scale Deflection

**Figure 8-21:** Typical "Processed Output" tab for Quasi-Static Temperature processing function

### 8.3.11 Narrow band fixed frequency

This processing function produces a narrow-band filtered output (Q=28), where the filter centre frequency is a user-configurable rotational speed value (this is defined in the **Center Speed in RPM** field). The filtered signal can represent absolute or relative vibration, dynamic pressure and so on.

This function can be used with the Dual Mathematical Function (see 8.3.19 Dual mathematical function) to perform line frequency rejection.

For the Narrow Band Fixed Frequency function, the two Processed Output tabs are replaced by a single one called Amplitude.

Typical Function and Amplitude tabs are shown in Figure 8-22 and Figure 8-23.

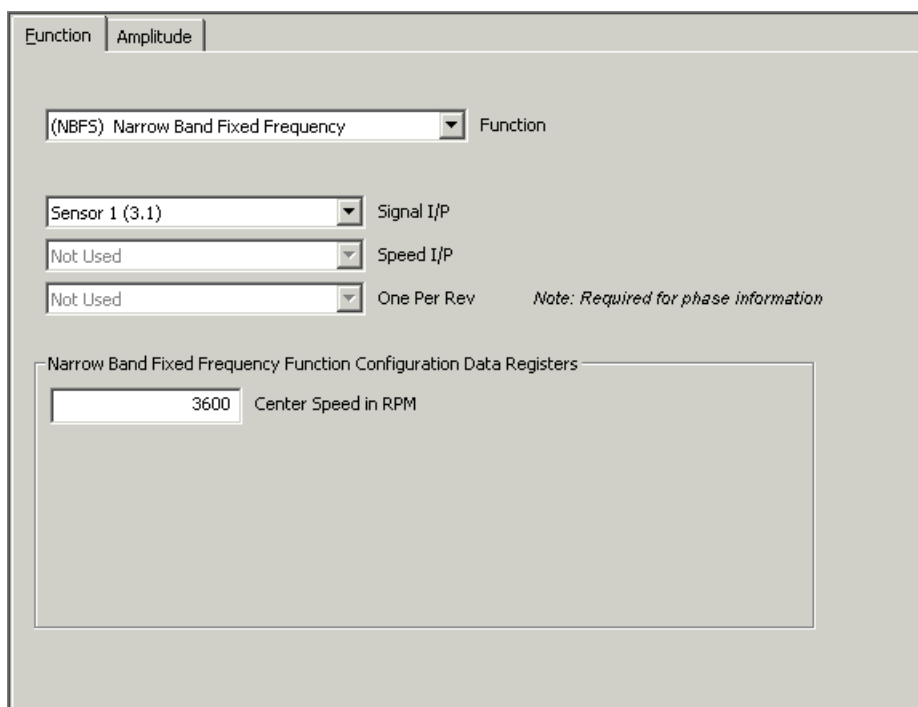

**Figure 8-22:** Typical “Function” tab for Narrow Band Fixed Frequency processing function

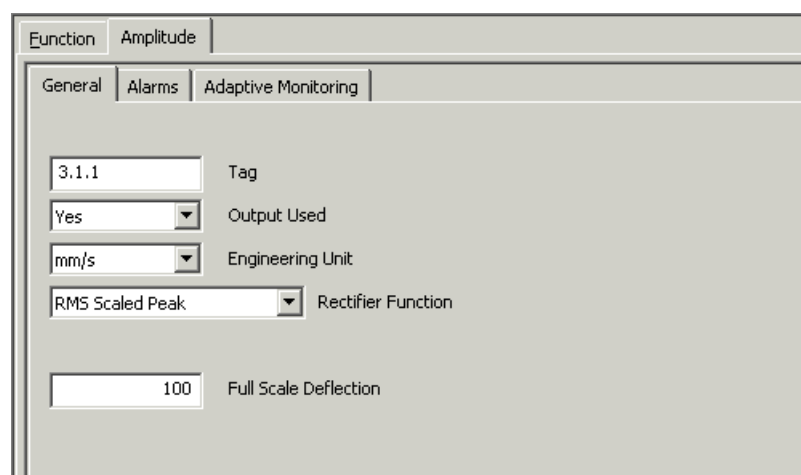

**Figure 8-23:** Typical “Amplitude” tab for Narrow Band Fixed Frequency processing function

### 8.3.12 $S_{max}$

The  $S_{max}$  processing function requires a dual processing channel to be used (that is, Channels 1&2 or Channels 3&4).

It is first necessary to configure both corresponding single channels to perform the Relative Shaft Vibration processing function.

Furthermore, for the  $S_{max}$  calculation to be possible, both single channels must be configured with the same settings. These are:

<b>Sensor Connected</b>	Yes.
<b>Sensor Sensitivity Unit</b>	Must be the same.
<b>Signal Sensitivity</b>	Must match within 10% of accuracy.
<b>Signal Dynamic</b>	Must match within 10% of accuracy.
<b>Signal Transmission Mode</b>	Must be the same.
<b>Bandwidth</b>	Must be the same.

For both individual channels, the bandwidth should be set to a value exceeding 20 times the rotational frequency. For example, if the rotational speed is 3000 RPM, corresponding to 50 Hz, a bandwidth in excess of 1000 Hz should be chosen.

The product of (Sensitivity x Dynamic) must match within 1% accuracy.

If the sensitivity and range correspond, the  $S_{max}$  value is given with the same accuracy as the individual process channels. If there is a mismatch of x% between the sensitivities of the two input channels, the accuracy of the  $S_{max}$  result is also x%, depending on the direction of the main axis of the S vector.

$S_{max}$  is expressed in the same measurement unit as that defined for both input channels. A True Peak rectifier function is always applied.

Typical Function and Processed Output tabs are shown in Figure 8-24 and Figure 8-25 respectively.

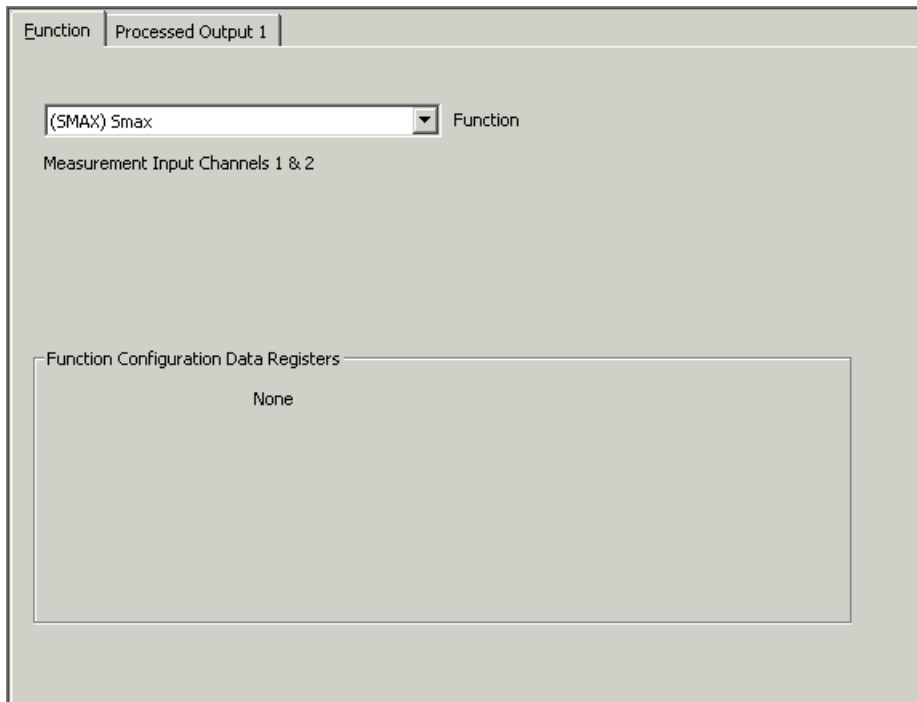

Figure 8-24: Typical "Function" tab for  $S_{max}$  processing function

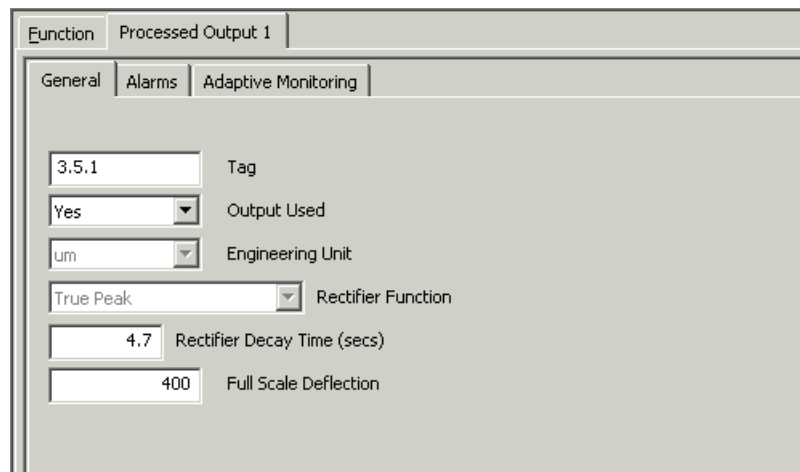

Figure 8-25: Typical "Processed Output" tab for  $S_{max}$  processing function

### 8.3.13 Absolute shaft vibration

The Absolute Shaft Vibration processing function requires a dual processing channel to be used (that is, Channels 1&2 or Channels 3&4).

It is first necessary to configure one of the corresponding single channels to perform the Broad Band Absolute Bearing Vibration processing function and the second single channel to perform the Relative Shaft Vibration processing function.

Typical Function and Processed Output tabs are shown in Figure 8-26 and Figure 8-27 respectively.



**Figure 8-26:** Typical “Function” tab for Absolute Shaft Vibration processing function

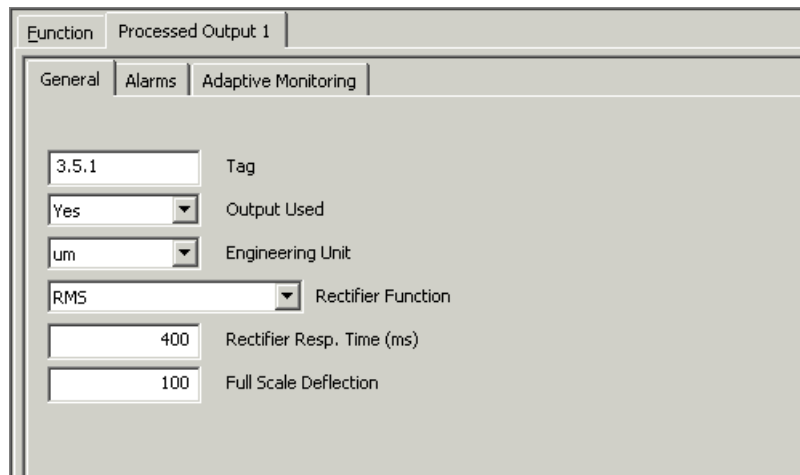

**Figure 8-27:** Typical “Processed Output” tab for Absolute Shaft Vibration processing function

### 8.3.14 Differential housing expansion

The Differential Housing Expansion processing function requires a dual processing channel to be used (that is, Channels 1&2 or Channels 3&4).

It is first necessary to configure both corresponding single channels to perform either:

- The Position processing function (see 8.3.4 Position) or
- The Absolute Housing Expansion processing function (see 8.3.6 Absolute housing expansion)

Both single channels must perform the same processing function (that is, it is not possible to have one processing Position and the other processing Absolute Housing Expansion).

The **Sensor Inverted** / **Direct Sensor** buttons must be configured identically for the two single channels.

Typical Function and Processed Output tabs are shown in Figure 8-28 and Figure 8-29 respectively.

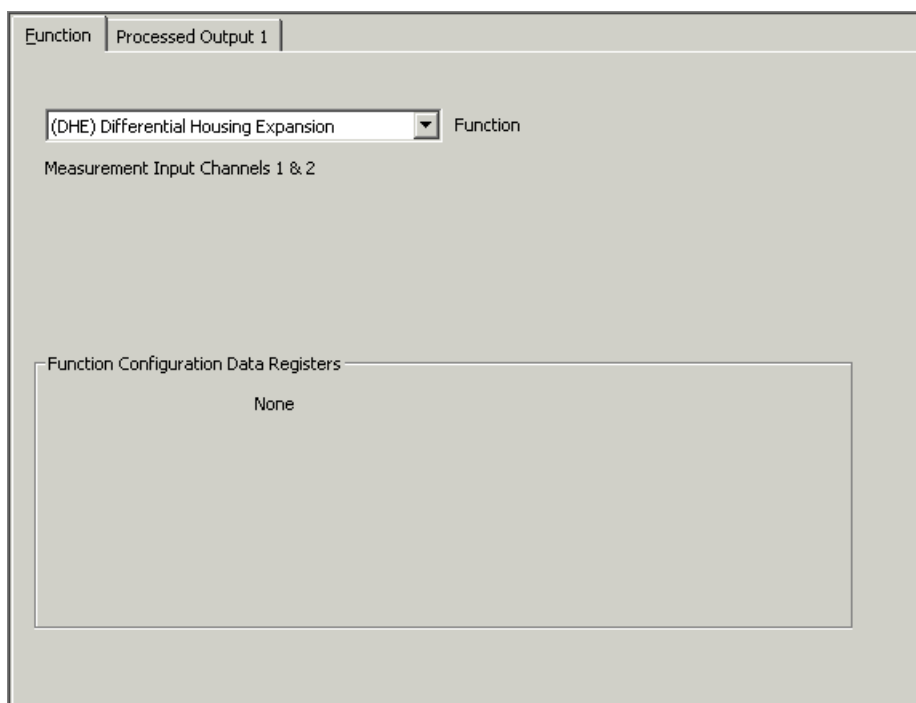

**Figure 8-28:** Typical "Function" tab for Differential Housing Expansion processing function

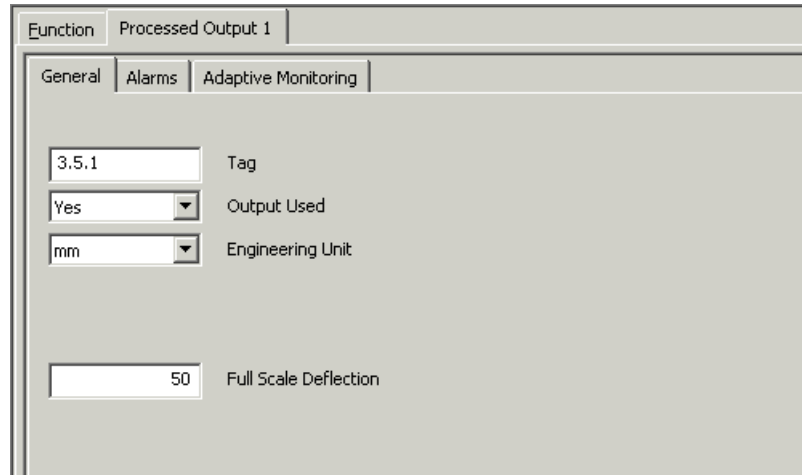

The screenshot shows a software configuration window titled "Processed Output 1". It has a tabbed interface with "Function" and "Processed Output 1" tabs. Under "Processed Output 1", there are sub-tabs for "General", "Alarms", and "Adaptive Monitoring". The "General" tab is selected and contains the following fields:

- Tag:** A text input field containing "3,5,1".
- Output Used:** A dropdown menu with "Yes" selected.
- Engineering Unit:** A dropdown menu with "mm" selected.
- Full Scale Deflection:** A text input field containing "50".

**Figure 8-29:** Typical "Processed Output" tab for Differential Housing Expansion processing function

### 8.3.15 Relative shaft expansion with shaft taper

The Relative Shaft Expansion with Shaft Taper processing function requires a dual processing channel to be used (that is, Channels 1&2 or Channels 3&4).

It is first necessary to configure both corresponding single channels to perform the Position processing function (see 8.3.4 Position).

If a single shaft taper is used, enter the taper angle (degrees) in the **First Channel Proximity Probe Mounting Angle** field. You should set the **Second Channel Proximity Probe Mounting Angle** field to 0.

If a double shaft taper is used, enter the taper angles (degrees) in the **First Channel Proximity Probe Mounting Angle** field and **Second Channel Proximity Probe Mounting Angle** field.

The measurement polarity is positive if the shaft moves in the direction from probe 1 to probe 2.

Typical Function and Processed Output tabs are shown in Figure 8-30 and Figure 8-31 respectively.

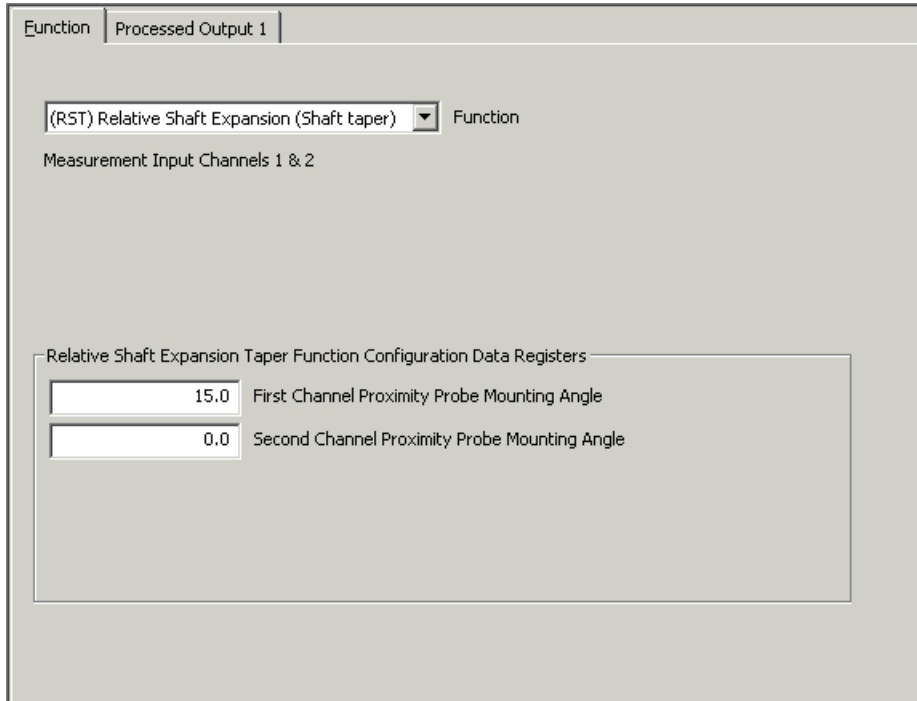

**Figure 8-30:** Typical "Function" tab for Relative Shaft Expansion with Shaft Taper processing function

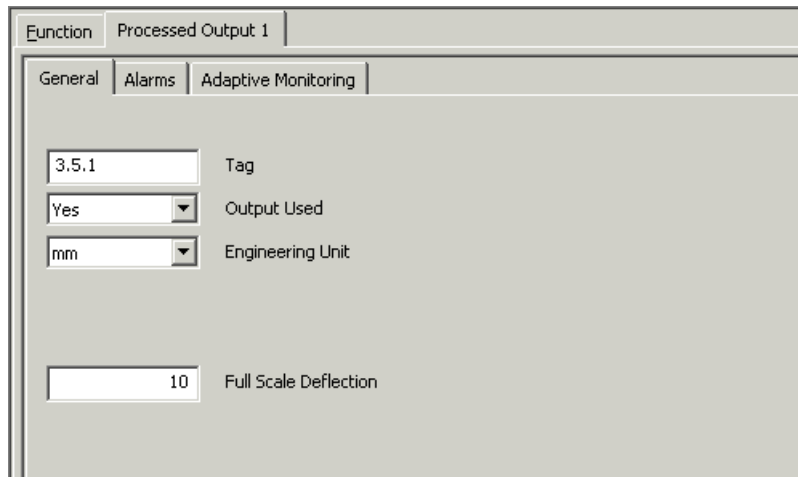

**Figure 8-31:** Typical "Processed Output" tab for Relative Shaft Expansion with Shaft Taper processing function

### 8.3.16 Relative shaft expansion with shaft collar

The Relative Shaft Expansion with Shaft Collar processing function requires a dual processing channel to be used (that is, Channels 1&2 or Channels 3&4).

It is first necessary to configure both corresponding single channels to perform the Position processing function (see 8.3.4 Position).

Typical Function and Processed Output tabs are shown in Figure 8-32 and Figure 8-33 respectively.

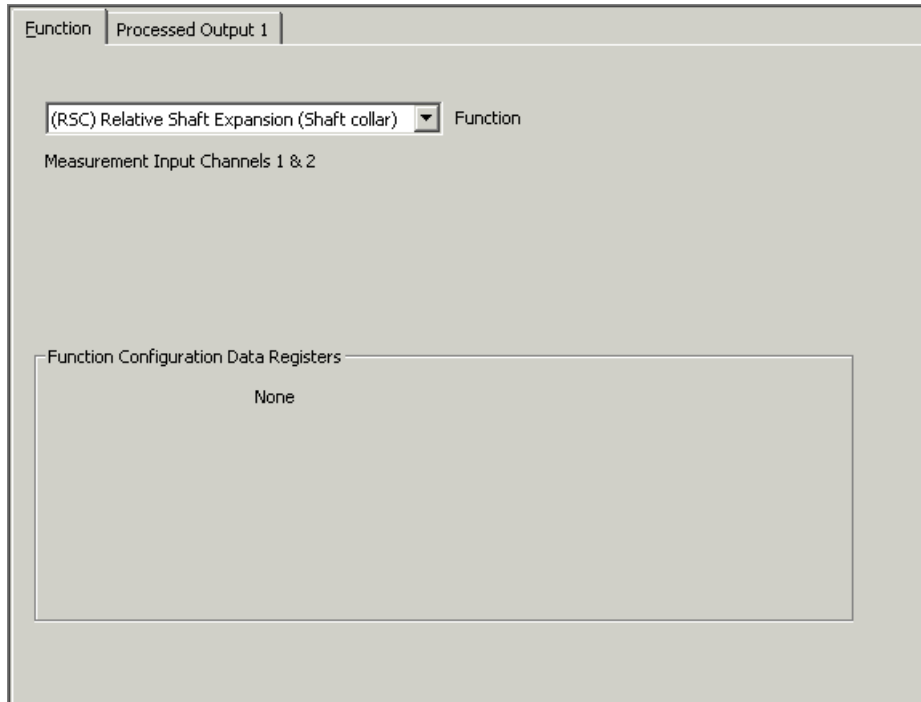

**Figure 8-32:** Typical "Function" tab for Relative Shaft Expansion with Shaft Collar processing function

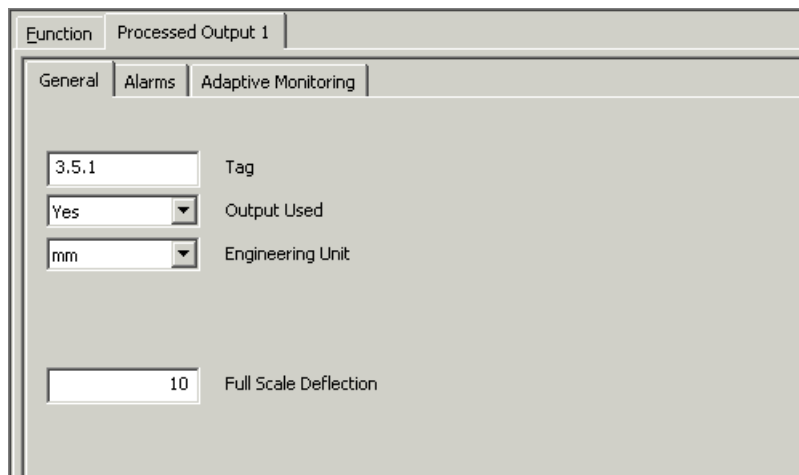

**Figure 8-33:** Typical "Processed Output" tab for Relative Shaft Expansion with Shaft Collar processing function

### 8.3.17 Delta quasi-static pressure

The Delta Quasi-Static Pressure processing function requires a dual processing channel to be used (that is, Channels 1&2 or Channels 3&4).

It is first necessary to configure both corresponding single channels to perform the Quasi-Static Pressure processing function.

---

**NOTE:** See 8.3.9 Quasi-static pressure for further information on Quasi-Static Pressure processing.

---

The resulting value is given by:  $\Delta \text{Pressure} = \text{Pressure 1} - \text{Pressure 2}$

Typical Function and Processed Output tabs are shown in Figure 8-34 and Figure 8-35 respectively.

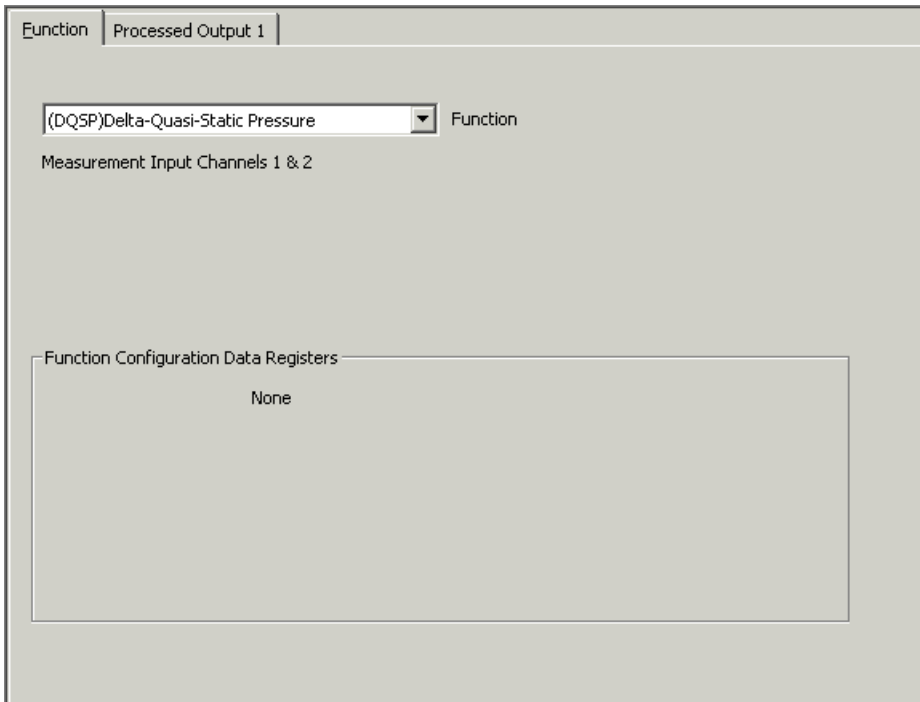

**Figure 8-34:** Typical "Function" tab for Delta Quasi-Static Pressure processing function

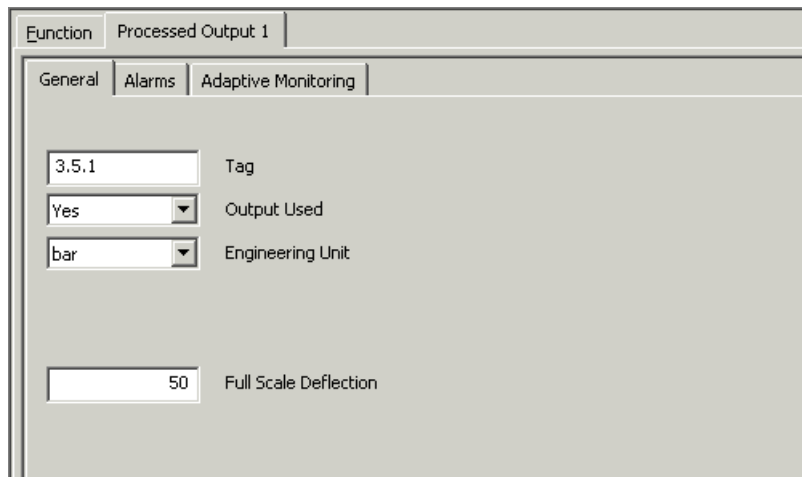

**Figure 8-35:** Typical "Processed Output" tab for Delta Quasi-Static Pressure processing function

### 8.3.18 Delta quasi-static temperature

The Delta Quasi-Static Temperature processing function requires a dual processing channel to be used (either Channels 1&2 or Channels 3&4).

It is first necessary to configure both corresponding single channels to perform the Quasi-Static Temperature processing function.

**NOTE:** See 8.3.10 Quasi-static temperature for further information on Quasi-Static Temperature processing.

The resulting value is given by:  $\Delta \text{Temperature} = \text{Temperature 1} - \text{Temperature 2}$

Typical Function and Processed Output tabs are shown in Figure 8-36 and Figure 8-37 respectively.

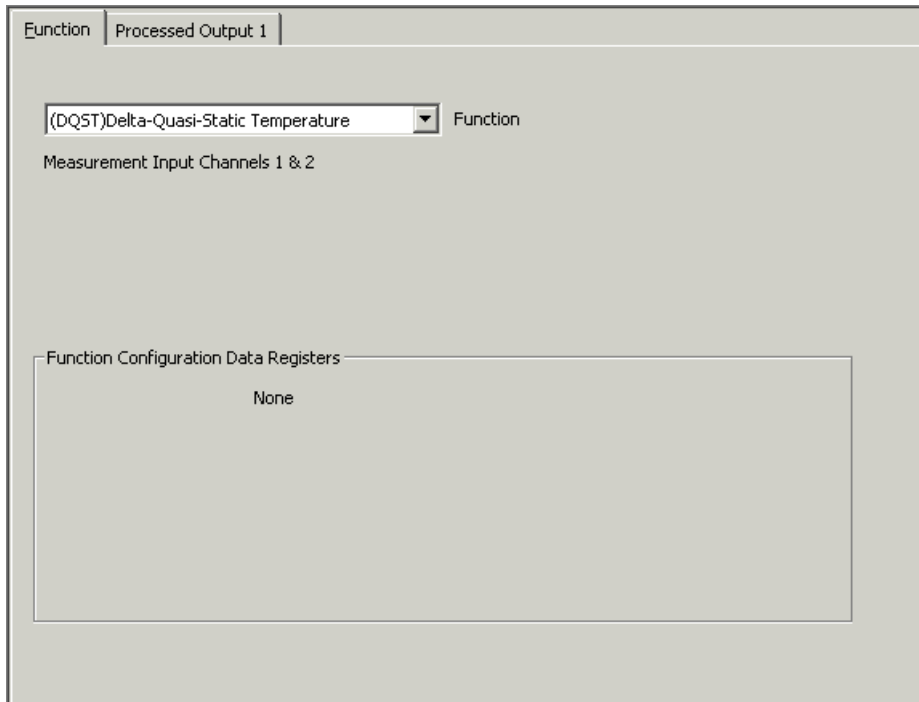

**Figure 8-36:** Typical “Function” tab for Delta Quasi-Static Temperature processing function

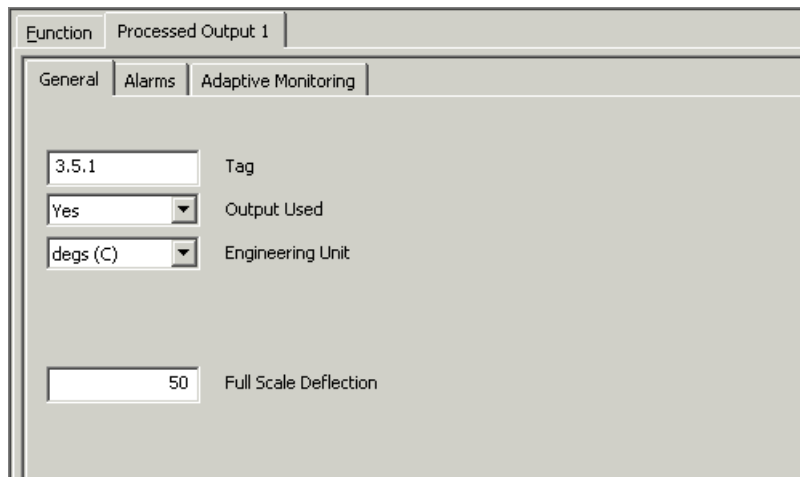

**Figure 8-37:** Typical “Processed Output” tab for Delta Quasi-Static Temperature processing function

### 8.3.19 Dual mathematical function

The Dual Mathematical Function (DMF) requires a dual processing channel to be used (that is, Channels 1&2 or Channels 3&4).

This processing function supports the following mathematical operations:

- **RMS Sum** which performs the RMS addition of two single-processing input channels:  
 $((Channel\ 1)^2 + (Channel\ 2)^2)^{0.5}$  or  $((Channel\ 3)^2 + (Channel\ 4)^2)^{0.5}$

The **RMS Sum** function requires that both input channels are configured with an RMS rectifier.

- **RMS Subtraction** which performs the RMS subtraction of two single-processing input channels:  
 $((Channel\ 1)^2 - (Channel\ 2)^2)^{0.5}$  or  $((Channel\ 3)^2 - (Channel\ 4)^2)^{0.5}$

The **RMS Subtraction** function requires that both input channels are configured with an RMS rectifier.

---

**NOTE:** For **RMS Subtraction**, if  $(Channel\ 2)^2 > (Channel\ 1)^2$  or  $(Channel\ 4)^2 > (Channel\ 3)^2$  then zero (0.0) is returned.

---

- **SUM** which performs the addition of two single-processing input channels:  
 $(Channel\ 1 + Channel\ 2)$  or  $(Channel\ 3 + Channel\ 4)$

The **SUM** function requires that both input channels are configured with the same rectifier.

- **SUBTRACTION** which performs the subtraction of two single-processing input channels:  
 $(Channel\ 1 - Channel\ 2)$  or  $(Channel\ 3 - Channel\ 4)$

The **SUBTRACTION** function requires that both input channels are configured with the same rectifier.

- **X & Y MIN** which selects the smaller value from two single-processing input channels:  
 $Minimum\ \{ (Channel\ 1 , Channel\ 2) \}$  or  $Minimum\ \{ (Channel\ 3 , Channel\ 4) \}$

The **X & Y MIN** function requires that both input channels are configured with the same rectifier.

- **X & Y MAX** which selects the larger value from two single-processing input channels:  
 $Maximum\ \{ (Channel\ 1 , Channel\ 2) \}$  or  $Maximum\ \{ (Channel\ 3 , Channel\ 4) \}$

The **X & Y MAX** function requires that both input channels are configured with the same rectifier.

In general, to use Dual Mathematical Function (DMF) processing with two single-processing input channels, both single-processing input channels (Channel 1 & 2 or Channel 3 & 4) must be configured with:

- The same single-channel processing function.  
 For example, Broad Band Absolute Bearing Vibration (BBAB) or Relative Shaft Vibration (RS).
- Engineering Units from the same family.  
 For example, if Channel 1 is in  $\mu\text{m}$ , Channel 2 can be in mils (both being units of displacement). Similarly, if Channel 1 is in inch/s, Channel 2 can be in mm/s (both being units of velocity).
- Rectifier Functions from the same rectifier group.  
 For example, RMS, RMS Scaled AVG, RMS Scaled Peak and RMS Scaled Peak-to-Peak are all rectifier functions from the same RMS-based rectifier group. However, the configuration does not have to be the same for both channels, for example, Channel 1 may be configured for RMS Scaled Peak and Channel 2 for RMS Scaled AVG.

---

**NOTE:** The Dual Mathematical Function (DMF) processing function only operates on the first processed output from each single-channel processing.  
Refer to the *VM600 Machinery Protection System (MPS)* hardware manual for further information.

---

**NOTE:** The Dual Mathematical Function (DMF) processing function must be set to “No Processing” in order to change the processing function for the associated single-processing channels.

---

Typical Function and Processed Output tabs are shown in Figure 8-38 and Figure 8-39 respectively.

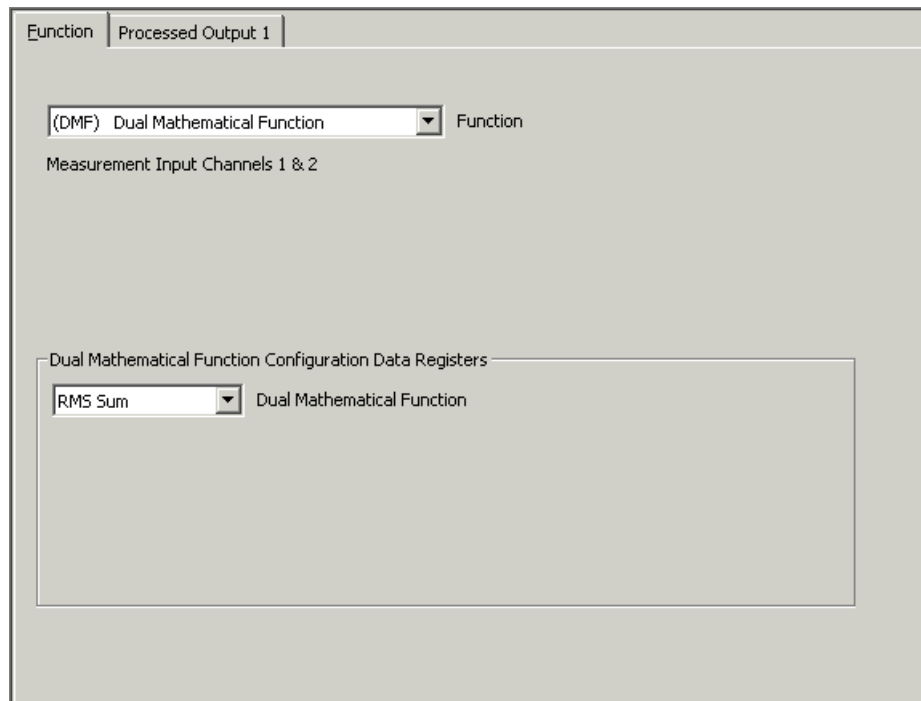

**Figure 8-38:** Typical “Function” tab for Dual Mathematical Function

The screenshot shows a configuration window for 'Processed Output 1'. It has three sub-tabs: 'General', 'Alarms', and 'Adaptive Monitoring'. The 'General' tab is active and contains the following fields:

- Tag:** A text input field containing '3.5.1'.
- Output Used:** A dropdown menu with 'Yes' selected.
- Engineering Unit:** A dropdown menu with 'mm/s' selected.
- Rectifier Function:** A dropdown menu with 'RMS' selected.
- Rectifier Resp. Time (ms):** A text input field containing '400'.
- Full Scale Deflection:** A text input field containing '50'.

**Figure 8-39:** Typical “Processed Output” tab for Dual Mathematical Function

## 8.4 Parameter fields found on the “Processed Output” tabs

Most single processing functions can have up to two outputs (Output 1 and Output 2). These can be set independently. For example, you can select raw vibration, expressed in g, on Output 1, and an integrated value, expressed in mm/s, on Output 2.

---

**NOTE:** Refer to the *VM600 Machinery Protection System (MPS)* hardware manual for further information on these outputs.

---

If the processing function is Relative Shaft Vibration (RS), the second output is automatically the gap value.

If the function is Narrow Band (Tracking) Vibration (NB), the second output is automatically the phase (measured in degrees).

The description of the following fields are shown in Figure 8-3.

### Tag

This field is the identifier for the selected sensor. If this field is left blank, a default tag is inserted automatically. This has the form x.y, where x is the card slot number and y is the channel identifier.

### Output Used

If one of the two outputs is not used, set the corresponding **Output Used** field to No. This disables calculation and monitoring.

### Engineering Unit

This unit may be the same as defined for the input channel (in the **Sensor Sensitivity Unit** field, accessible when the Inputs \ Measurement Channels branch of the configuration tree structure is selected), or different.

If different, the data is converted automatically. An integration or differentiation may be performed according to the physical unit selected.

Examples:

- 1- If the **Sensor Sensitivity Unit** for the input channel is g, and the **Engineering Unit** is mm/s, then a single integration operation is performed before the rectification.
- 2- If the **Sensor Sensitivity Unit** for the input channel is  $\mu\text{m}$ , and the **Engineering Unit** is mm/s, then a single differentiation operation is performed before the rectification.

No differentiation or integration is performed if the processing function is Position, Eccentricity, or any of the dual functions.

Only one differentiation is allowed (for Output 1) for the Relative Shaft Vibration function.

One or two integrations are allowed for broad-band and narrow-band processing.

### Rectifier Function

Peak and Peak-to-Peak are the so-called "true" rectification techniques (also known as qualifiers). These are performed in the time domain, directly on the raw signals.

RMS-related rectification types are all based on the RMS calculation. The values are obtained by scaling as follows:

Scaled Peak	1.414 x RMS value.
Scaled Peak-to-Peak	2 x 1.414 x RMS value.
Scaled AVG (Mean)	0.900 x RMS value.

The multiplication factors correspond to the scaling of a sine waveform to the different kinds of rectification.

AVG corresponds to a mean value rectification technique. It is the average of the absolute value of a signal, whereas the RMS value represents the square root of the average of the squared signal. The result using AVG is slightly different from the RMS value.

N/A must be selected for DC measurement types (displacement, position, gap and so on).

### Rectifier Response or Decay Time

This field is used to select the response or decay time. It is context sensitive:

If the rectification type is RMS or AVG related, it corresponds to the rectification response time. The smaller the response time becomes, the less time it takes for the measurement to reach its value. However, the noise on the output becomes correspondingly larger. A common response time for general use is 400 milliseconds. The response time must be larger than the rotation period of the machine; ideally two or three times this period.

If True Peak or True Peak-to-Peak rectification is used, the decay time is asked for. The decay time represents the time after which the output decays down to about 10% of its value, after the input decreases to 0 (zero). Note that with this type of rectification the response time is immediate, therefore the rectifier catches all peaks in the signal.

### Full Scale Deflection

This field is used to enter the full-scale value of the output, in the units defined in the **Engineering Unit** field. If the value is signed (that is, it can be positive or negative), enter only the positive full-scale value.

Examples:

- For an output of 0 to 100 mm/s, enter 100 as the full-scale value.
- For a position value that can lie in the range -1 to +1 mm, enter 1 as the full-scale value.

## 8.5 Configuring alarms

### 8.5.1 General

To configure alarm parameters for a given channel:

- 1- Select the Alarms tab from the Processed Output channel you wish to configure and a tab resembling that shown in Figure 8-40 appears.
- 2- The tab allows the following parameters to be set for the Danger+, Alert+, Alert- and Danger- thresholds:
  - The alarm level.
  - The hysteresis value.
  - The alarm delay time.
  - Whether the alarm output enabled or disabled.
  - Whether the alarm status is latched or unlatched.

---

**NOTE:** Further information is given in 8.5.2 Configuring Alert and Danger parameters.

---

- 3- If the Adaptive Monitoring feature or Direct Trip Multiply feature is required, click the Adaptive Monitoring tab to access a window resembling that shown in Figure 8-41. Adaptive Monitoring allows dynamic alarms to be set for measurement channels. In transient mode (for example, during machine run-up), alarms levels are modified as a function of a parameter such as speed. Direct Trip Multiply allows alarm parameters for measurement channels to be scaled by a multiplication factor when the TM input on the IOC4T card is grounded.

---

**NOTE:** Further information is given in 8.6 Adaptive monitoring and direct trip multiply.

---

- 4- If logical combinations of alarms are required, select the Alarm Logical Combination branch of the configuration tree structure.

---

**NOTE:** Further information is given in 9 Defining logical combinations of alarms (MPC4 and MPC4 SIL).

---

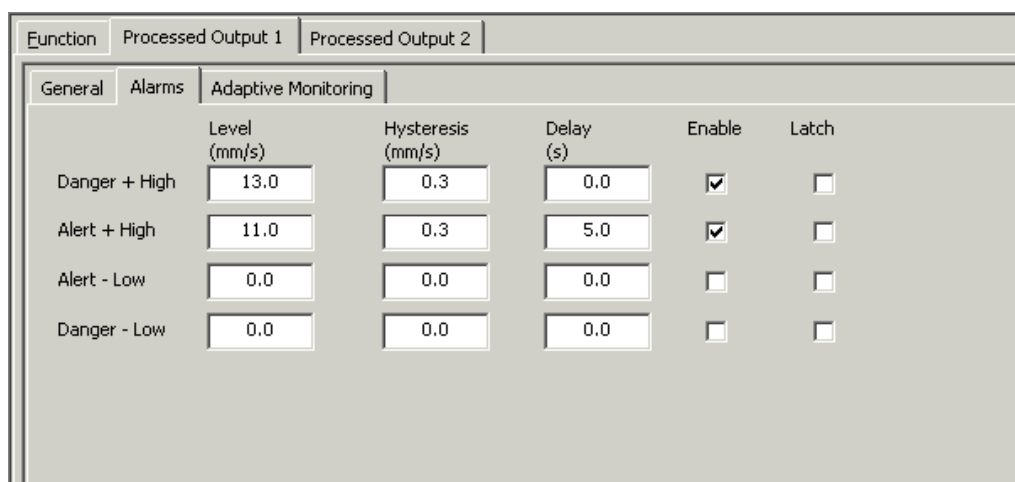

**Figure 8-40:** Tab to configure the Alert and Danger parameters

## 8.5.2 Configuring Alert and Danger parameters

The tab shown in Figure 8-40 is used to configure the Alert and Danger thresholds. These alarms act on open collector outputs which can be used to switch relays.

To map an alarm to a specific relay, select the Output Mapping \ Discrete Outputs branch of the configuration tree structure.

---

**NOTE:** Further information is given in 10 Output mapping (MPC4 and MPC4 SIL).

---

The following fields may be configured (see also Figure 8-40):

### Level

This must be expressed in the selected output unit (Engineering Unit). See the description of the Processed Output tab in 8.4 Parameter fields found on the “Processed Output” tabs.

The values must be entered in decreasing order from:

Danger+ High	to
Alert+ High	to
Alert- Low	to
Danger- Low	

### Hysteresis

This must also be expressed in the selected output unit (Engineering Unit).

The hysteresis value must always be positive. It is added to the A- and D- levels and subtracted from the A+ and D+ levels internally, to give hysteresis capability to the system. It is advised to set a hysteresis value of about 2 to 5% of the desired full scale for the output, but the optimum value actually depends on the noise on the output.

### Delay

The signal level must be over (or under, in the case of low-level alarms) the alarm level (including the hysteresis value) for longer than the alarm delay time before an alarm is generated.

---

**NOTE:** The range of alarm delay values supported by the measurement channels of an MPC4 card is 0 to 60 seconds with a resolution of 0.1 second (100 milliseconds). Correct operation cannot be guaranteed if a value outside the supported range of alarm delay values is configured.

---

### Enabled

Selecting this check box means the alarm output is enabled, otherwise it is disabled.

### Latch

Selecting this check box means the alarm output is latched, otherwise it is unlatched.

## 8.6 Adaptive monitoring and direct trip multiply

The configuration of Adaptive Monitoring and Direct Trip Multiply parameters are both done by first selecting the Adaptive Monitoring tab from the Processed Output channel you wish to configure.

---

**NOTE:** Refer to the *VM600 Machinery Protection System (MPS)* hardware manual for further information on the Adaptive Monitoring and Direct Trip Multiply features.

---

### 8.6.1 Configuring adaptive monitoring parameters

The tab shown in Figure 8-41 is used to configure Adaptive Monitoring parameters.

Select the triggering parameter from the list available in the **Adaptive Reference** field. This is usually a speed value.

Up to 10 triggering values with a corresponding multiplication factor can be defined. The multiplication factor is applied to Alert and Danger levels.

In the example shown in Figure 8-41, the default multiplication factor of 1.0 is in effect up to a speed of 10 Hz, Between 10 and 20 Hz, the factor is 1.5. Between 20 and 30 Hz, the factor is 2.0, and so on.

When filling in the table, the first "From" speed value must be zero, and the first "To" speed value must be different from zero. Otherwise, the software considers that the Adaptive Monitoring function is not in effect.

The table should be filled in with increasing speed values (or data values). When the maximum speed has been entered (100 Hz in the example shown in Figure 8-41), the remaining speed values should be set to zero.

Whenever the speed is outside all the configured intervals, no multiplier is applied to the alarms.

The check boxes in the **Adaptive Alarms Enable** column should normally be selected. If a check box is cleared, the Adaptive Monitoring function is disabled for the corresponding frequency band.

Click the **Display** button to obtain a graphical representation of the multiplication factor versus speed. An example is shown in Figure 8-42.

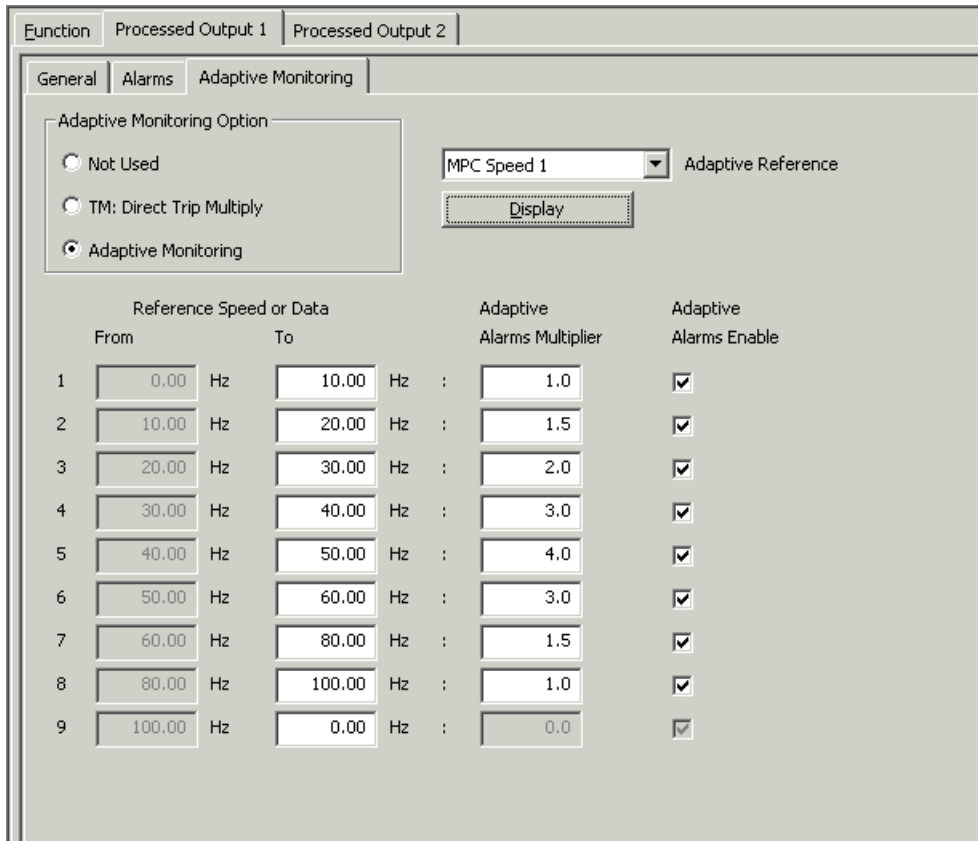

Figure 8-41: Tab for configuring the Adaptive Monitoring parameters

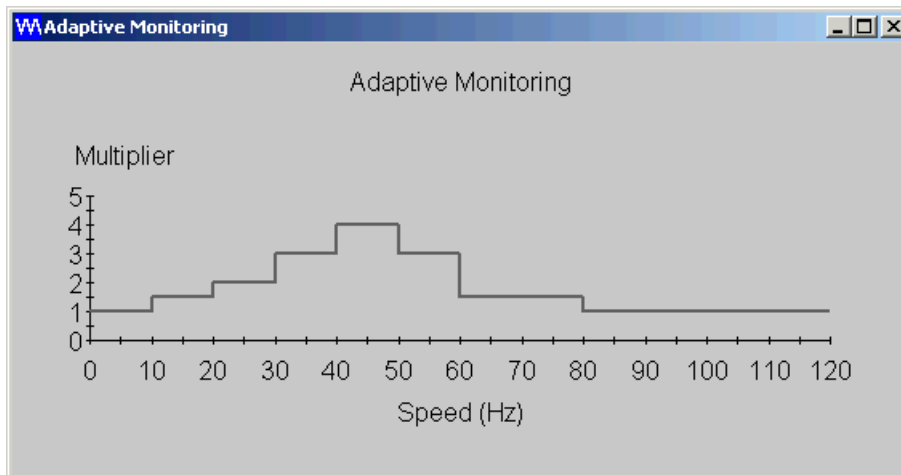

Figure 8-42: Graphical representation of the multiplication factor versus speed

### 8.6.2 Configuring direct trip multiply parameters

To use this option, first click the **TM: Direct Trip Multiply** button. A tab resembling that shown in Figure 8-43 appears.

The multiplication factor should be entered in the **TM: Alarm Multiplier** field.

All alarm levels (Alert, Danger) for this channel are multiplied by this factor when the TM contact on the back of the IOC4T card is grounded.

---

**NOTE:** If you want to disable the Danger relays only, you can use the Danger Bypass (DB) function. To activate this function, ground the DB contact on the back of the IOC4T card.

---

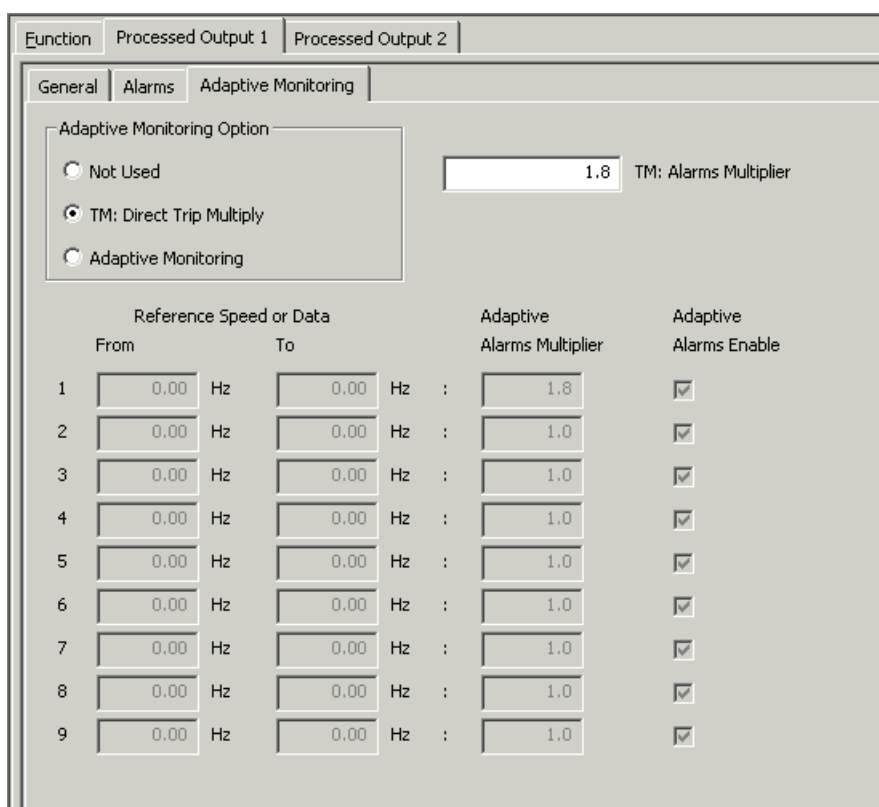

Figure 8-43: Selecting the Direct Trip Multiply function

## 9 DEFINING LOGICAL COMBINATIONS OF ALARMS (MPC4 AND MPC4 SIL)

### 9.1 Introduction

This section describes the Alarm Logical Combination branch of the configuration tree structure, visible when an MPC4 or MPC4 SIL card is selected (see Figure 9-1). This branch allows logical combinations of alarms to be defined. The VM600 MPS1 software allows eight basic functions and four advanced functions to be configured.

**NOTE:** Refer to the *VM600 Machinery Protection System (MPS)* hardware manual for further information on logical combinations of alarms.

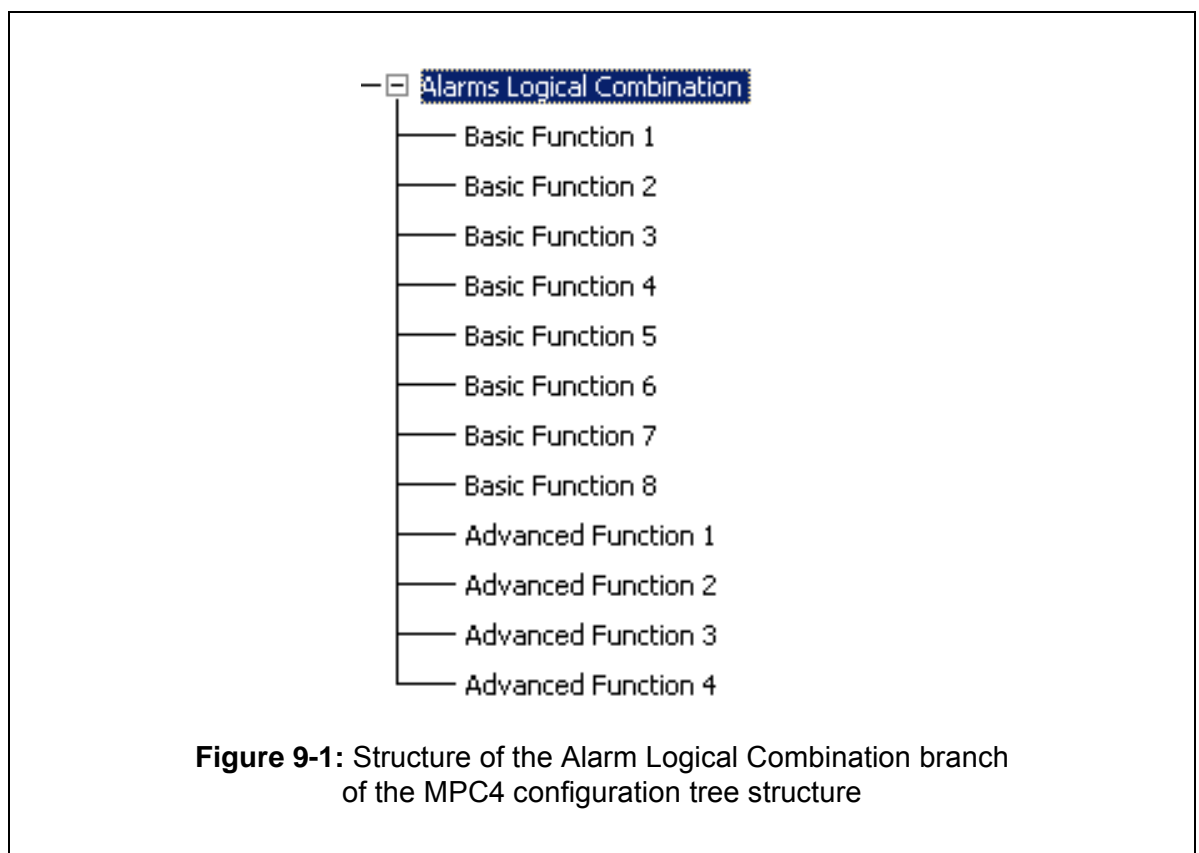

**Figure 9-1:** Structure of the Alarm Logical Combination branch of the MPC4 configuration tree structure

### 9.2 Defining a basic alarm function

To define a basic alarm function:

- 1- Select one of the eight Basic Functions (Basic Function 1 to Basic Function 8) from the Alarm Logical Combination branch of the tree structure (Figure 9-1). A window resembling that shown in Figure 9-2 appears.
- 2- The alarms are listed on several dialog boxes that are accessible by clicking the appropriate tab (Figure 9-2 to Figure 9-5). Clear or select the check boxes next to the individual alarms concerned (a check mark indicates the alarm has been selected).

The Function & Common tab (Figure 9-2) allows the user to select status-related flags and control line flags (for example, indicating TM, DB or AR is active).

The tab for the single measurement channels (Figure 9-3) allows the Alert and Danger alarms for the outputs of these channels to be selected, as well as certain status-related information.

The tab for the dual channels (Figure 9-4) allows the Alert and Danger alarms for the dual channels to be selected, as well as certain status-related information. Alarms for the speed channels are also selected here.

The Diagnostics tab (Figure 9-5) allows the user to select status-related alarms that are common to the entire MPC4 card.

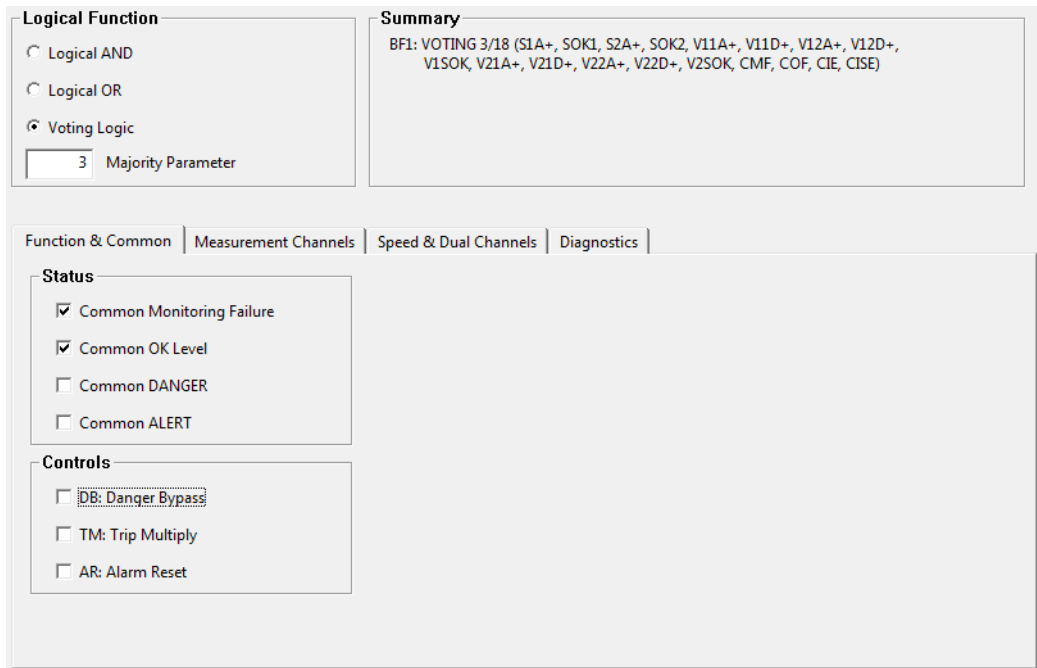

**Figure 9-2:** Window to select alarms for basic alarm combinations (Function & Common tab)

- 3- Select the logical function (AND, OR, Voting Logic) by clicking the appropriate button on the Function & Common tab (**Logical AND**, **Logical OR** or **Voting Logic**), as shown in Figure 9-2.

If **Voting Logic** is selected, the **Majority Parameter** field appears and a value should be entered. For example, if you have selected nine alarm check boxes and you enter the value 3 in the **Majority Parameter** field, the basic alarm function signals an alarm when any four of the nine alarms are active.

**Logical Function**

Logical AND

Logical OR

Voting Logic

Majority Parameter

**Summary**

BFI: VOTING 3/18 (S1A+, SOK1, S2A+, SOK2, V11A+, V11D+, V12A+, V12D+, V1SOK, V21A+, V21D+, V22A+, V22D+, V2SOK, CMF, COF, CIE, CISE)

---

Function & Common

Measurement Channels

Speed & Dual Channels

Diagnostics

	CH. 1		CH. 2		CH. 3		CH. 4	
O.K.	<input checked="" type="checkbox"/>	<input checked="" type="checkbox"/>	<input checked="" type="checkbox"/>	<input checked="" type="checkbox"/>	<input type="checkbox"/>	<input type="checkbox"/>	<input type="checkbox"/>	<input type="checkbox"/>
Channel Inhibit	<input type="checkbox"/>	<input type="checkbox"/>	<input type="checkbox"/>	<input type="checkbox"/>	<input type="checkbox"/>	<input type="checkbox"/>	<input type="checkbox"/>	<input type="checkbox"/>
PGA Saturation Error	<input type="checkbox"/>	<input type="checkbox"/>	<input type="checkbox"/>	<input type="checkbox"/>	<input type="checkbox"/>	<input type="checkbox"/>	<input type="checkbox"/>	<input type="checkbox"/>
Output	1	2	1	2	1	2	1	2
Invalid Output	<input type="checkbox"/>	<input type="checkbox"/>	<input type="checkbox"/>	<input type="checkbox"/>	<input type="checkbox"/>	<input type="checkbox"/>	<input type="checkbox"/>	<input type="checkbox"/>
Danger + High	<input checked="" type="checkbox"/>	<input checked="" type="checkbox"/>	<input checked="" type="checkbox"/>	<input checked="" type="checkbox"/>	<input type="checkbox"/>	<input type="checkbox"/>	<input type="checkbox"/>	<input type="checkbox"/>
Alert + High	<input checked="" type="checkbox"/>	<input checked="" type="checkbox"/>	<input checked="" type="checkbox"/>	<input checked="" type="checkbox"/>	<input type="checkbox"/>	<input type="checkbox"/>	<input type="checkbox"/>	<input type="checkbox"/>
Alert - Low	<input type="checkbox"/>	<input type="checkbox"/>	<input type="checkbox"/>	<input type="checkbox"/>	<input type="checkbox"/>	<input type="checkbox"/>	<input type="checkbox"/>	<input type="checkbox"/>
Danger - Low	<input type="checkbox"/>	<input type="checkbox"/>	<input type="checkbox"/>	<input type="checkbox"/>	<input type="checkbox"/>	<input type="checkbox"/>	<input type="checkbox"/>	<input type="checkbox"/>

**Figure 9-3:** Window to select alarms for basic alarm combinations (tab for single measurement channels)

**Notes:**

The **Invalid Output** flag (Figure 9-3 and Figure 9-4) is an OR function between the following possible alarms for a channel:

- DSP saturation error
- DSP overflow error
- Track out of range
- Track lost
- PGA saturation error
- Sensor OK system check (SOK).

Usually this error is due to incorrect configuration of the MPC4 card and can be corrected by reconfiguring the card.

**Logical Function**

Logical AND

Logical OR

Voting Logic

Majority Parameter

**Summary**

BF1: VOTING 3/18 (S1A+, SOK1, S2A+, SOK2, V11A+, V11D+, V12A+, V12D+, V1SOK, V21A+, V21D+, V22A+, V22D+, V2SOK, CMF, COF, CIE, CISE)

Function & Common

Measurement Channels

Speed & Dual Channels

Diagnostics

	Spd 1	Spd 2	Dual1&2	Dual3&4
O.K.	<input checked="" type="checkbox"/>	<input checked="" type="checkbox"/>	<input type="checkbox"/>	<input type="checkbox"/>
Channel Inhibit	<input type="checkbox"/>	<input type="checkbox"/>	<input type="checkbox"/>	<input type="checkbox"/>
PGA Saturation Error	<input type="checkbox"/>	<input type="checkbox"/>	<input type="checkbox"/>	<input type="checkbox"/>
Invalid Output	<input type="checkbox"/>	<input type="checkbox"/>	<input type="checkbox"/>	<input type="checkbox"/>
Danger + High	<input type="checkbox"/>	<input type="checkbox"/>	<input type="checkbox"/>	<input type="checkbox"/>
Alert + High	<input checked="" type="checkbox"/>	<input checked="" type="checkbox"/>	<input type="checkbox"/>	<input type="checkbox"/>
Alert - Low	<input type="checkbox"/>	<input type="checkbox"/>	<input type="checkbox"/>	<input type="checkbox"/>
Danger - Low	<input type="checkbox"/>	<input type="checkbox"/>	<input type="checkbox"/>	<input type="checkbox"/>

**Figure 9-4:** Window to select alarms for basic alarm combinations (tab for speed and dual channels)

**Logical Function**

Logical AND

Logical OR

Voting Logic

Majority Parameter

**Summary**

BF1: VOTING 1/18 (S1A+, SOK1, S2A+, SOK2, V11A+, V11D+, V12A+, V12D+, V1SOK, V21A+, V21D+, V22A+, V22D+, V2SOK, CMF, COF, CIE, CISE)

Function & Common

Measurement Channels

Speed & Dual Channels

Diagnostics

**MPC Processing**

MPC Card Running

Processing Error

DSP Saturation Error

**Signals**

Common Mode Range Overflow

Input Signal Error

Input Saturation Error

**Error Log**

Status Latched

**Tracking & Speed**

Speed Out Of Limit

Track Lost

Track Out Of Range

**Figure 9-5:** Window to select alarms for basic alarm combinations (Diagnostics tab)

### 9.3 Defining an advanced alarm function

To define an advanced alarm function:

- 1- Select one of the four Advanced Functions (Advanced Function 1 to Advanced Function 4) from the Alarm Logical Combination branch of the tree structure (Figure 9-1). A window resembling that shown in Figure 9-6 appears.
- 2- Clear or select the check boxes next to the basic functions concerned (a check mark indicates the basic function has been selected).
- 3- Select the logical function (either AND or OR).

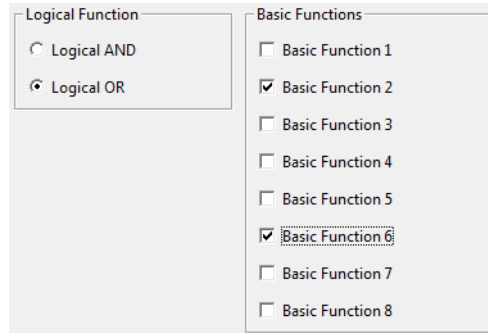

**Figure 9-6:** Window to configure advanced alarm functions

**THIS PAGE INTENTIONALLY LEFT BLANK**

# 10 OUTPUT MAPPING (MPC4 AND MPC4 SIL)

## 10.1 Introduction

This section describes the Output Mapping branch of the configuration tree structure, visible when an MPC4 or MPC4 SIL card is selected (see Figure 10-1).

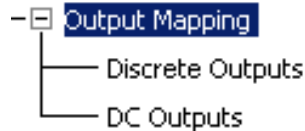

**Figure 10-1:** Structure of the Output Mapping branch of the MPC4 configuration tree structure

The **Output Mapping \ Discrete Outputs** branch allows global and individual alarms (for example, speed, vibration, dynamic pressure, MPC4 hardware and software status) to be attributed to specific relays on the IOC and RLC cards.

The **Output Mapping \ DC Outputs** branch allows the four DC outputs (DC OUT 1, DC OUT 2, DC OUT 3 and DC OUT 4) to be configured.

## 10.2 Mapping alarms (discrete outputs)

The IOC4T card has four local relays. Alarm signals can be directly attributed to these relays under software control. No hardware adjustments need to be made, with the exception of placing jumpers on the IOC4T card to configure the relays as normally energised (NE) or normally de-energised (NDE), as well as normally open (NO) or normally closed (NC).

---

**NOTE:** Refer to the *VM600 Machinery Protection System (MPS)* hardware manual for further information on placing these jumpers.

---

If additional relays are needed, an RLC16 card containing 16 relays can be installed in the VM600 MPS. An alarm signal is attributed to a relay on the RLC16 in two stages:

- 1- The alarm signal is mapped to a relay using the VM600 MPS1 software. The user can choose whether the mapping takes place via the Open Collector Bus (OC Bus) or the Raw Bus.
- 2- If the OC Bus is used, a jumper must be set on the RLC16 card to enable the OC Bus line that is associated with that specific relay.  
or
- 3- If the Raw Bus is used, a jumper must be set on the IOC4T card to select one of the four Raw Bus line associated with that particular relay. Another jumper must be set on the RLC16 card to connect the Raw Bus line chosen to the specific relay.

---

**NOTE:** Refer to the *VM600 Machinery Protection System (MPS)* hardware manual for further information on using the OC Bus and the Raw Bus to switch relays on the RLC16.

---

Alarms are mapped to specific relays on the IOC4T card or RLC16 card (via OC Bus lines or Raw Bus lines) using the Discrete Outputs node in the Output Mapping branch of the configuration tree structure. When this node is selected, a relay mapping window appears (see Figure 10-2). This contains:

- 1- A Relay Mapping tree structure (left)
- 2- Three combo boxes for alarm selection. These fields have names which are context sensitive. For example, it is possible to see the following together:
  - **Common, Group** and **Status** (Figure 10-3) and
  - **Channel, Outputs** and **Status** (Figure 10-4)
- 3- An **Apply** button.

To map an alarm to a relay:

- 1- Click a node (small box containing a “+” sign) in the tree structure to show more of the hierarchy (Figure 10-3 shows the IOC Relays branch opened up).

Select the branches as follows:

<b>IOC Relays</b>	To select one of the 4 local relays on the IOC4T card.
<b>RLC / OC Bus</b>	To select one of the 16 relays on the RLC16 card using the OC Bus.
<b>RLC / Raw Bus</b>	To select one of the 16 relays on the RLC16 card using the Raw Bus.

Each line of a branch represents a relay. The numbers correspond to the relay numbers found on the rear panel of the respective card (IOC4T or RLC16).

- 2- Click the appropriate line to select a specific relay.
- 3- Choose an entry from the top-most combo box. This allows the choice of one of the speed channels, any single or dual channel, a logically combined alarm or a “common” signal.
- 4- Choose an entry from the middle combo box, if appropriate.

---

**NOTE:** The middle and lower-most combo boxes are context sensitive, that is, the options available in them depend on what is chosen in the top-most combo box.

---

- 5- Choose an entry from the lower-most combo box, if appropriate.
- 6- Click the **Apply** button to attribute the alarm signal to the relay. The line now shows the alarm designation (for example, in Figure 10-3, Relay 2 on the IOC4T is attributed to the Common Alert alarm).

You cannot attribute the same alarm to two different relays. If this is attempted, an error message appears asking if you want to delete the first mapping. Click **Yes** or **No** as appropriate.



Figure 10-2: Relay Mapping tree structure (for MPC4 card)

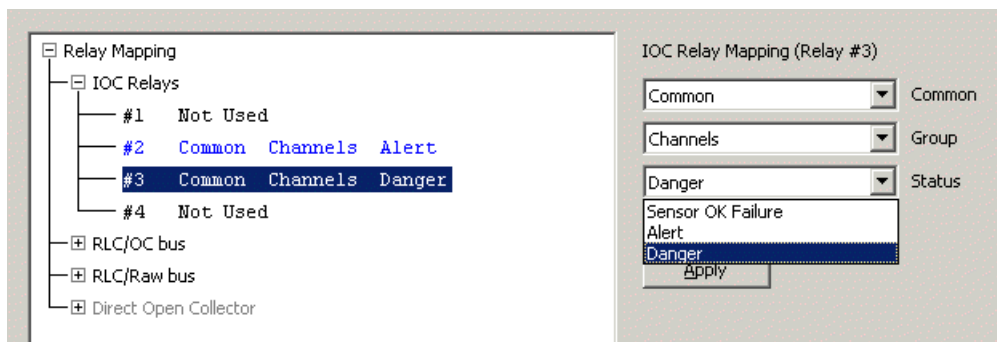

Figure 10-3: Example of attributing Relay 3 on the IOC4T card to the “Common Danger” alarm

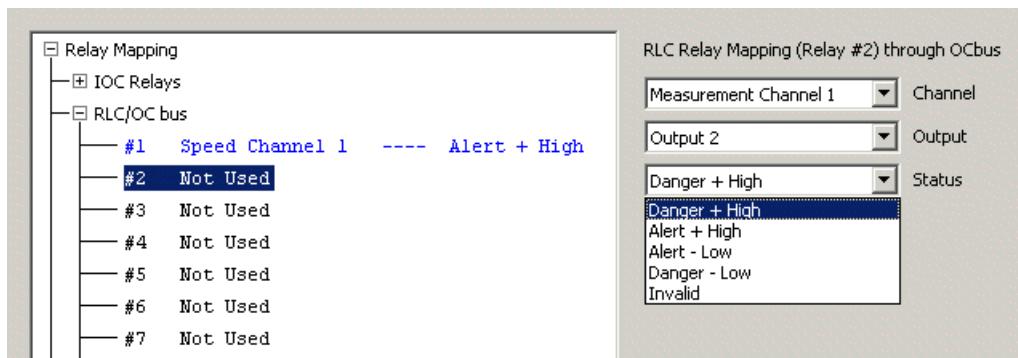

Figure 10-4: Example of attributing Relay 2 on the RLC16 card to the Danger+ alarm of Output 2 of Measurement Channel 1. The OC Bus is used to route the alarm.

### 10.3 Configuring DC outputs (analog outputs)

The IOC4T has four analog outputs (named DC OUT 1, DC OUT 2, DC OUT 3 and DC OUT 4). These can be configured individually to provide a voltage-based output (0 to 10 V) or a current-based output (4 to 20 mA). This choice is made by setting jumpers on the IOC4T card.

---

**NOTE:** Refer to the *VM600 Machinery Protection System (MPS)* hardware manual for further information on placing jumpers.

---

Specific signals may be attributed to each analog output by selecting the Output Mapping \ DC Outputs branch of the configuration tree structure. When this node is chosen, a DC Output Configuration window appears (see Figure 10-5).

To configure a DC output:

- 1- Click the **Setup** combo box to show the list of signals that can be chosen (Figure 10-6). Measurement channels, speed channels and OK values may be chosen.
- 2- Choose a signal from the list. The DC Output Channel Setup window appears (Figure 10-7).
- 3- Click the appropriate button to select the desired channel.

---

**NOTE:** For the IOC4T card, only DC Outputs 1 to 4 may be chosen. These correspond to DC OUT 1, DC OUT 2, DC OUT 3 and DC OUT 4 respectively.

---

- 4- Enter values in the **Minimum Level** and **Maximum Level** fields.  
In the example shown in Figure 10-7, 0 to 100 mm corresponds to 0 to 10 V or to 4 to 20 mA, depending on the hardware configuration.
- 5- Click **OK** to validate. The newly assigned analog output appears on the DC Output Configuration window (see Figure 10-8).

#### To delete an existing routing

To delete an existing analog output routing:

- 1- Select the signal again from the **Setup** combo box (Figure 10-6).
- 2- Select the **Not Used** button on the DC Output Channel Setup window (Figure 10-7).
- 3- Click **OK** to validate.

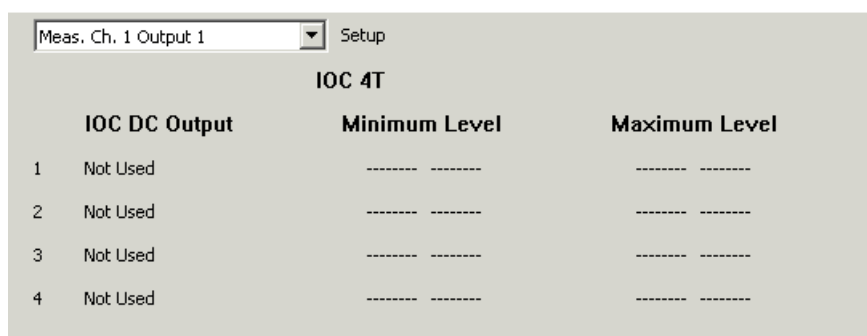

**Figure 10-5:** DC Outputs configuration window (for MPC4 card)

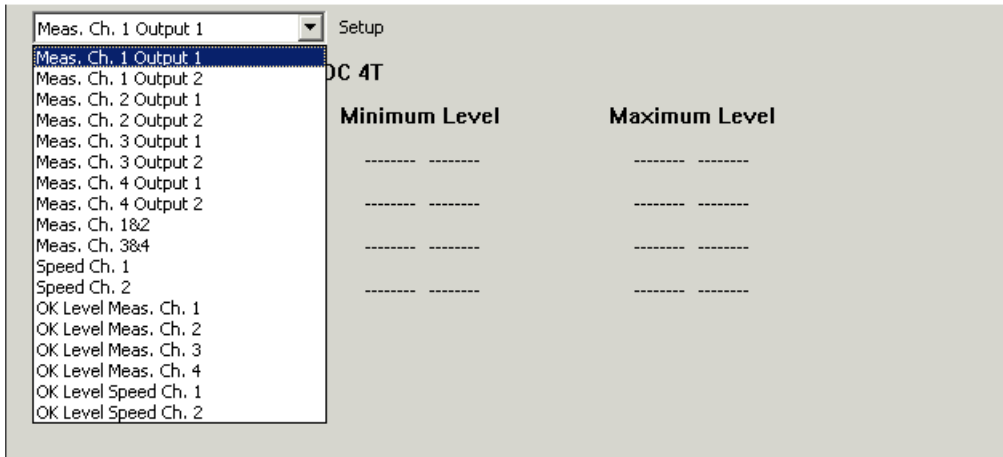

Figure 10-6: Setup combo box showing signals that can be chosen

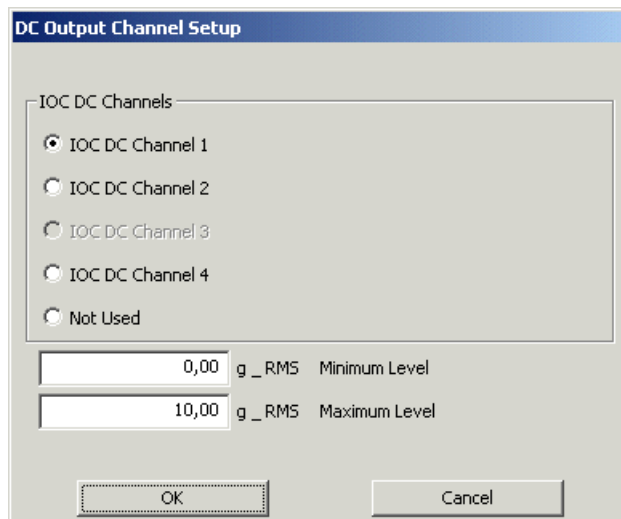

Figure 10-7: DC Output Channel Setup window

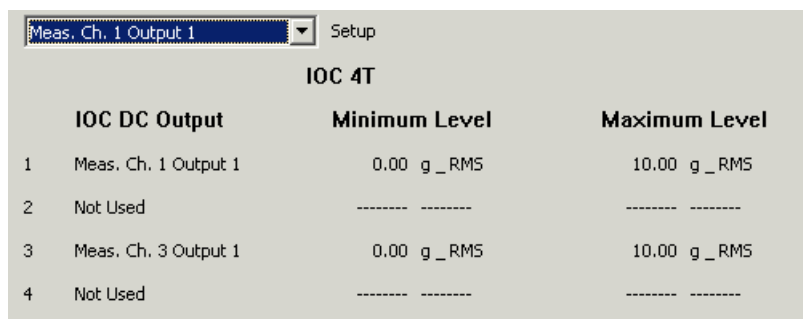

Figure 10-8: DC Outputs configuration window showing the newly defined DC output

**THIS PAGE INTENTIONALLY LEFT BLANK**

# 11 COMMUNICATIONS MENU (MPC4 AND MPC4 SIL)

## 11.1 Introduction

This section describes the commands available in the **Communications** drop-down menu at rack level and at MPC4 or MPC4 SIL card level (see 6 Main window menus and commands). The structure of the menu is shown in Figure 11-1.

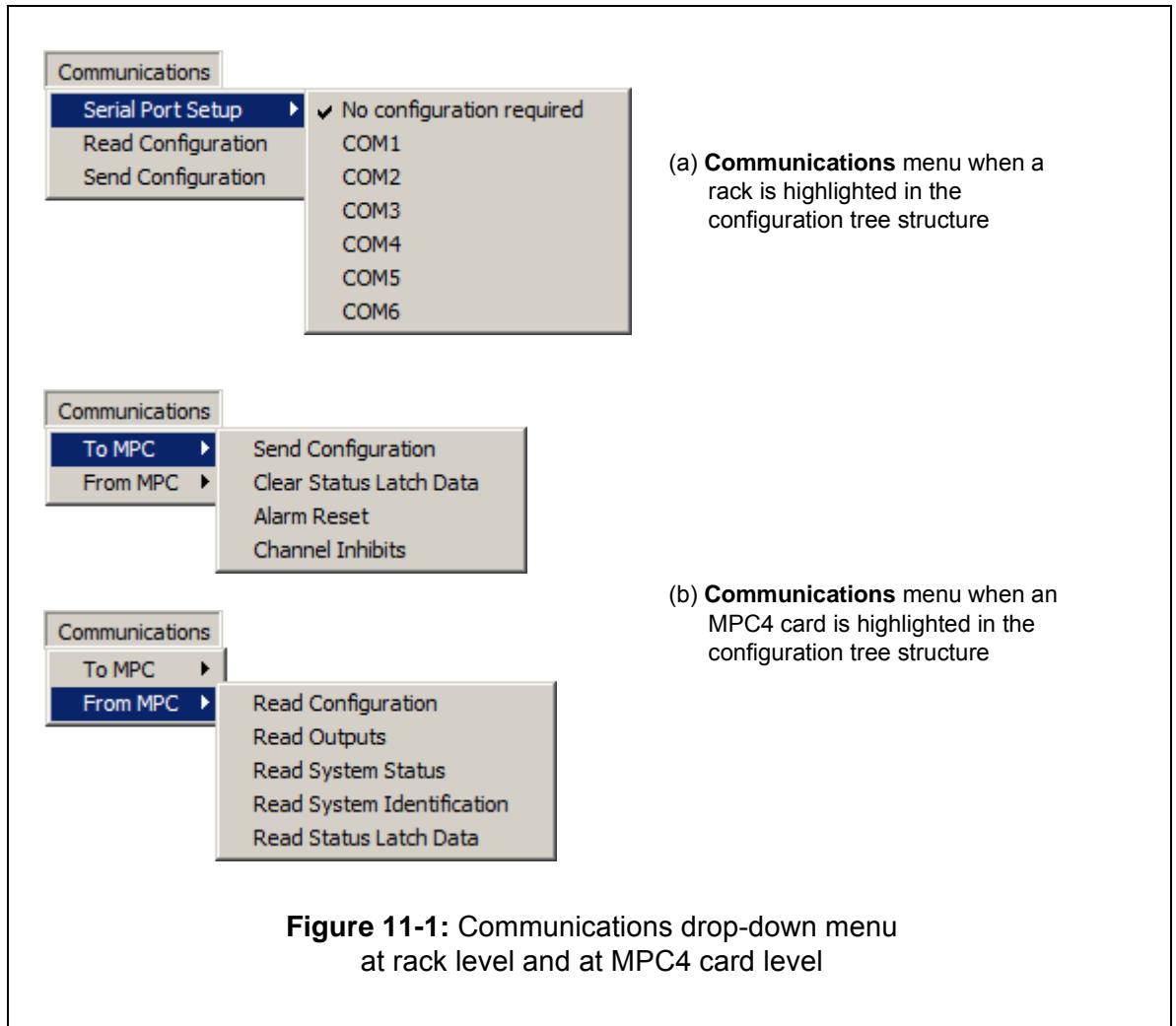

Note that at rack level (that is, when a rack is highlighted in the configuration tree structure), selecting **Read Configuration** uploads the configuration of all cards from the rack and selecting **Send Configuration** downloads the configuration of all cards to the rack.

See also 2.3.1.1 Safety (SIL) version of the MPC4 and 6.3.3 Sending a configuration to a VM600 rack or card.

## 11.2 Communication with a stand-alone rack (no CPUM present)

A stand-alone rack is defined as one that is not connected to a network via a CPUM card or a CPUM / IOCN card pair. Communication with individual cards in a stand-alone rack is possible using an RS-232 serial communications link.

### 11.2.1 Setup procedure

The following procedure allows communication to be established with cards in a stand-alone rack:

- 1- Connect an RS-232 communication cable between the appropriate serial interface port on the computer (COM1, COM2, COM3 or COM4) and the RS-232 connector (9-pin D-sub) on the front panel of the appropriate MPC4 card.
- 2- Select the rack in the configuration tree structure and ensure that the **CPU Present** check box is not selected (see Figure 11-2).
- 3- Select the appropriate MPC4 card in the configuration tree structure.
- 4- Select **Serial Port Setup** from the **Communications** drop-down menu, and choose the appropriate interface port (COM1, COM2, COM3 or COM4).

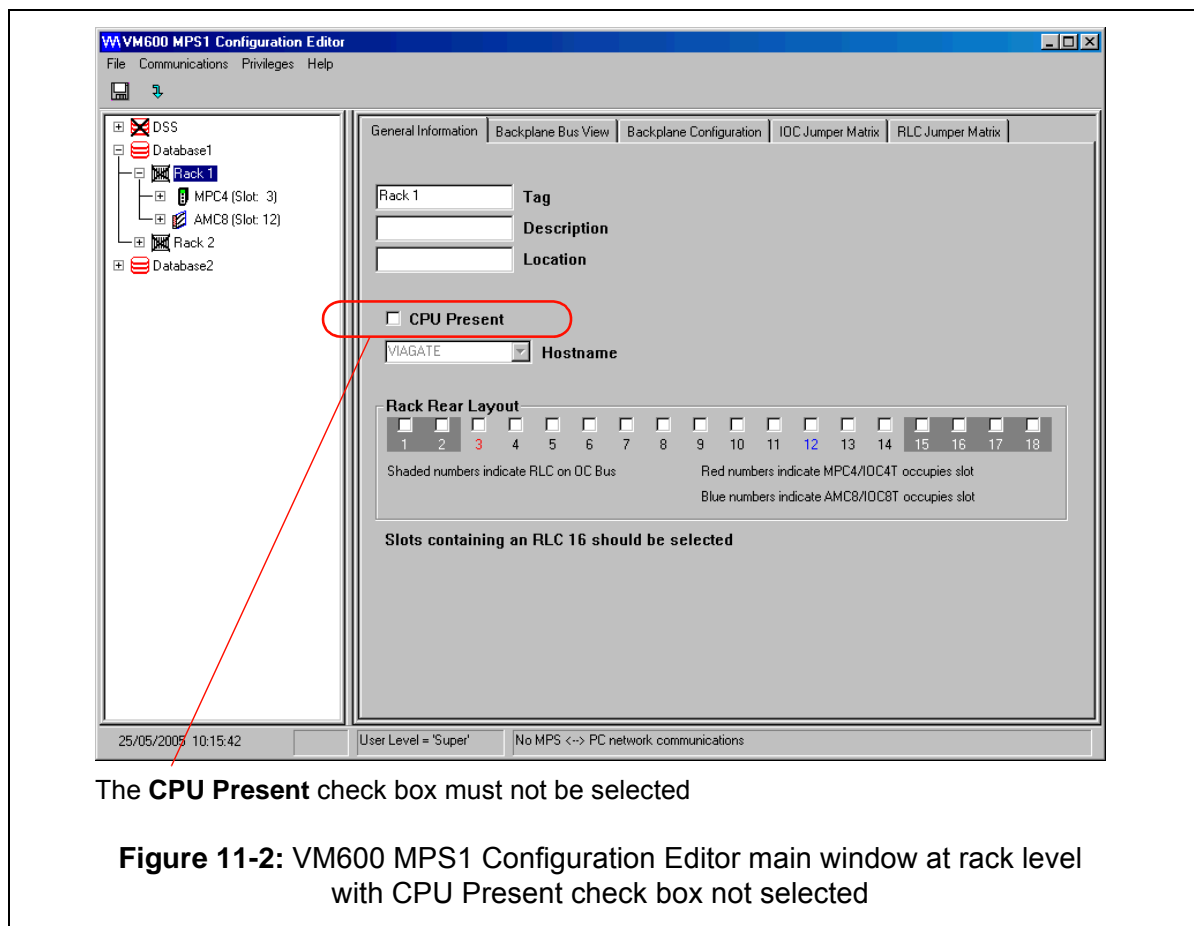

Once communication has been established, the operator can use the menu commands to perform more or less the same functions that are possible with a networked rack.

The only difference between a networked rack and a stand-alone rack is that with a networked rack the configuration of all cards in the rack can be either downloaded or read in one single operation (via the CPUM card).

With a stand-alone rack, you can only download or read the configuration of one card at a time. To communicate with another card, the physical link (RS-232 communication cable) must first be moved to that card.

### 11.2.2 Communicating with an MPC4 card in a stand-alone rack

It is possible to communicate with an MPC4 card in a stand-alone rack. This is illustrated by the example shown in Figure 11-3. In this example, the VM600 MPS1 software is installed on a computer with a COM1 serial port. COM1 is physically connected to the MPC4 card (in slot 3) using an RS-232 cable.

In the VM600 MPS1 session, COM1 is selected, allowing the MPC4 card can be configured and communicated with.

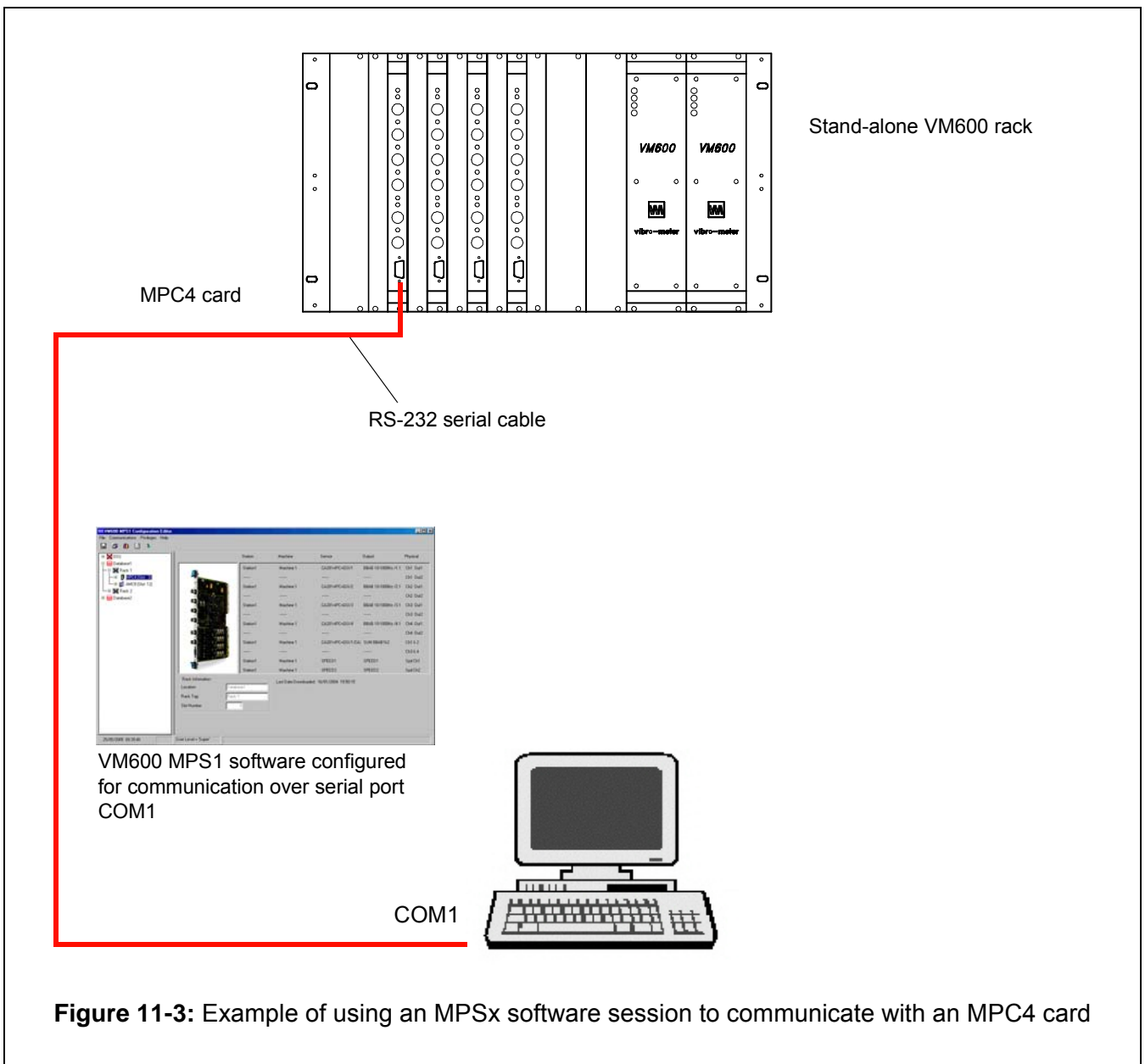

Figure 11-3: Example of using an MPSx software session to communicate with an MPC4 card

### 11.3 Communication with a networked rack (CPUM present)

A rack containing a CPUM card or a CPUM / IOCN card pair can be connected to a network. This allows communication with the rack over an Ethernet link.

**NOTE:** Refer to the *VM600 Networking* manual for further information on networking.

The following procedure allows communication to be established with cards in a networked rack:

- 1- Select the rack in the configuration tree structure (see Figure 11-4).
- 2- Activate the **CPU Present** check box.
- 3- Drop down the **Hostname** list and select a host name (that is, rack name) that corresponds to the rack in question (Figure 11-4).

Alternatively, type the IP address of the rack, in dot-decimal notation, directly in the **Hostname** field (for example, 10.10.56.56).

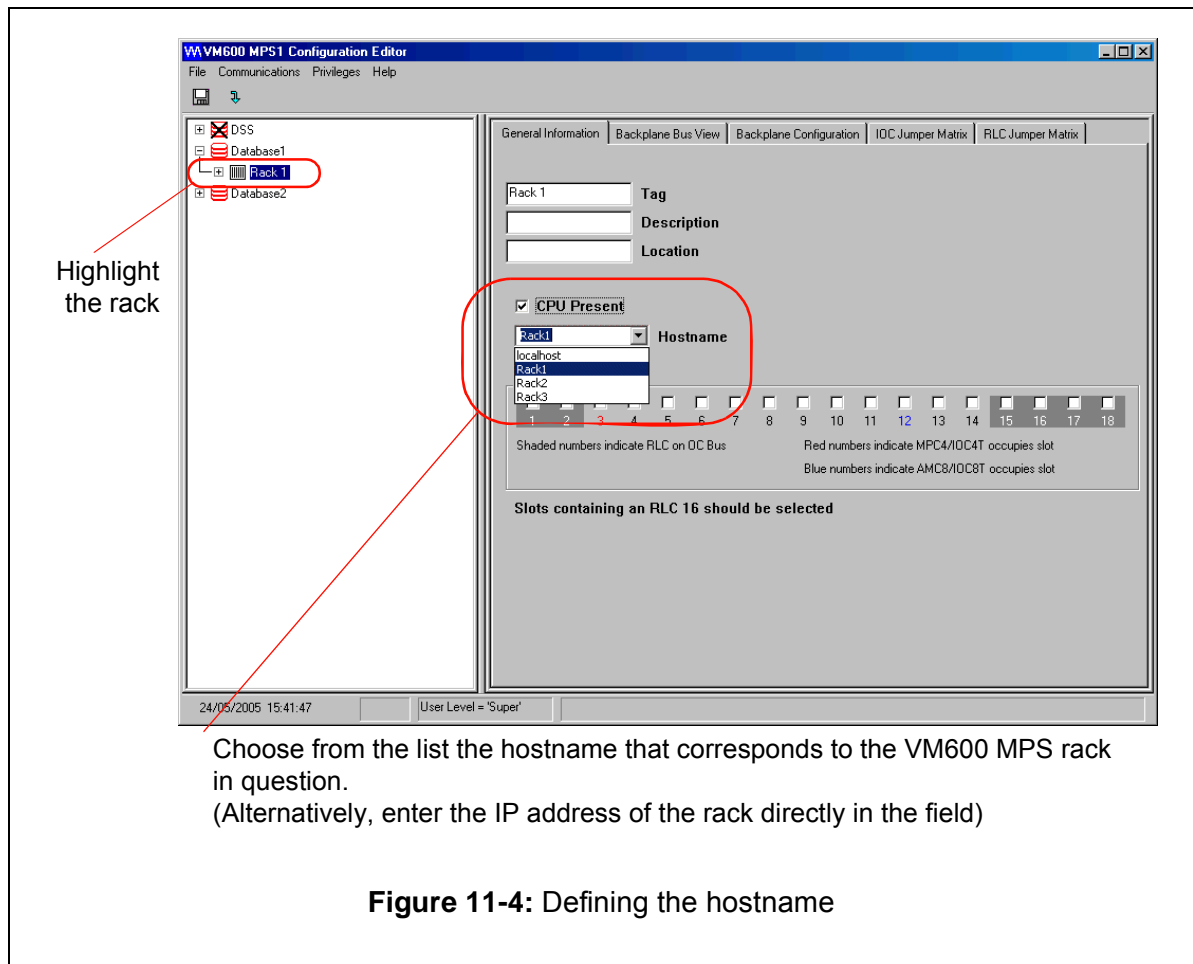

## 11.4 Downloading the configuration (Send Configuration)

See also 2.3.1.1 Safety (SIL) version of the MPC4 and 6.3.3 Sending a configuration to a VM600 rack or card.

### Networked rack

To download an entire rack configuration to a networked rack:

- 1- Activate the communications link (Ethernet or PPP) to the rack as described in 11.3 Communication with a networked rack (CPUM present).
- 2- From the configuration tree structure, select the rack you want to download the configuration to.  
This should be the same rack as in step 1 above.
- 3- Select **Send Configuration** from the **Communications** drop-down menu.

To download a single card's configuration to a networked rack:

- 1- In the configuration tree structure, select the card you want to download.
- 2- Select **Communications, To MPC**, and **Send Configuration**.

### Stand-alone rack

For a stand-alone rack, the configuration of each card can be downloaded one card at a time as follows:

- 1- Activate the communications link (RS-232 serial link) to the card in question as described in 11.2.1 Setup procedure.
- 2- From the configuration tree structure, select the card you want to download the configuration to.  
This should be the same card as in step 1 above.
- 3- Select **To MPC** from the **Communications** drop-down menu and choose the **Send Configuration** command.

## 11.5 Reading the configuration (Read Configuration)

When a new card is installed in a slot its configuration can be "uploaded" to the VM600 MPS1 software for analysis.

If required, the configuration can then be saved under a particular name by selecting **Export MPC Configuration** from the **File** drop-down menu.

### Networked rack

To upload the configuration of an individual card, or the entire rack, to the personal computer:

- 1- Activate the communications link (Ethernet or PPP) to the rack as described in 11.3 Communication with a networked rack (CPUM present).
- 2- From the configuration tree structure, select the card you want to upload the configuration from.  
You can also upload the configuration of the entire rack by selecting the rack in the configuration tree structure.
- 3- Select **Read Configuration** from the **Communications** drop-down menu.

### Stand-alone rack

For a stand-alone rack, the configuration of each card can be uploaded one card at a time as follows:

- 1- Activate the communications link (RS-232 serial link) to the card in question as described in 11.2.1 Setup procedure.
- 2- From the configuration tree structure, select the card you want to upload the configuration from.  
This should be the same card as in step 1 above.
- 3- Select **From MPC** from the **Communications** drop-down menu and choose the **Read Configuration** command.

## 11.6 Testing the communications link (Read System Identification)

To test the communication link, select **From MPC** from the **Communications** menu and choose the **Read System Identification** command. The System Identification window appears, as shown in Figure 11-5.

In the case of a problem, this window contains information that can be communicated to Meggitt Sensing Systems customer support.

Serial Number:	ABCDEF
MPC Hardware Part Number:	200-510-100-XXX
MPC Software Part Number:	209-510-200-YYY
IOC Identification:	Type: IOC 4T
	Slot Number: 3
	Slot Assignment: 3

Figure 11-5: System Identification window (for MPC4 / IOC4T card pair)

## 11.7 The status latch (clearing and reading)

When an alarm or flag with the ability to be latched occurs, the event is noted on a “latched event list”. This can be examined by selecting **From MPC** from the **Communications** menu and then choosing the **Read Status Latch Data** command. A window with three tabs resembling those shown in Figure 11-6 to Figure 11-8 appears.

This feature is useful for checking if an event has occurred over a certain period of time (that is, since the last Clear Status Latch Data operation), when the operator cannot permanently check the output data.

The latched data can be cleared at any moment by selecting **To MPC** from the **Communications** menu and then choosing the **Clear Status Latch Data** command.

The colour convention used on the windows is as follows:

- White** No event (the bit is off).
- Yellow** Indicates an Alert condition (A+ or A- level) on any measurement channel (single or dual), any speed channel.
- Red** Indicates a Danger condition (D+ or D- level) on any measurement channel (single or dual). Also used for flags on the Common and Diagnostics tab (except for the controls).
- Purple** Indicates an OK Level error.
- Blue** Used to indicate that a control signal (TM, DB and AR) is active.

The status bar at the bottom of each window provides a summary of the status. The five boxes are interpreted as shown in Table 11-1 below:

**Table 11-1:** Interpretation of indicators on the status bar

Label	Colour (if bit = 1)	Number (shown inside box)
OK	Purple	Sum of OK failures for all channels
D	Red	Sum of Dangers for all channels
A	Yellow	Sum of Alerts for all channels
Diags	Red	Sum of Diagnostics flags, including PGA saturation errors
Ctrls	Blue	Sum of control signals (TM, DB or AR) active

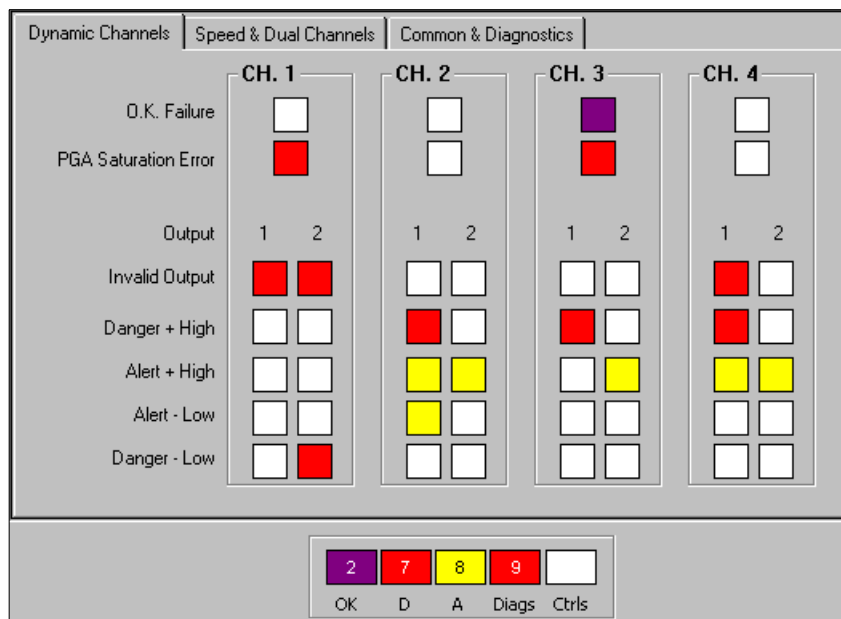

**Figure 11-6:** Read Status Latch Data window (Dynamic Channels tab)

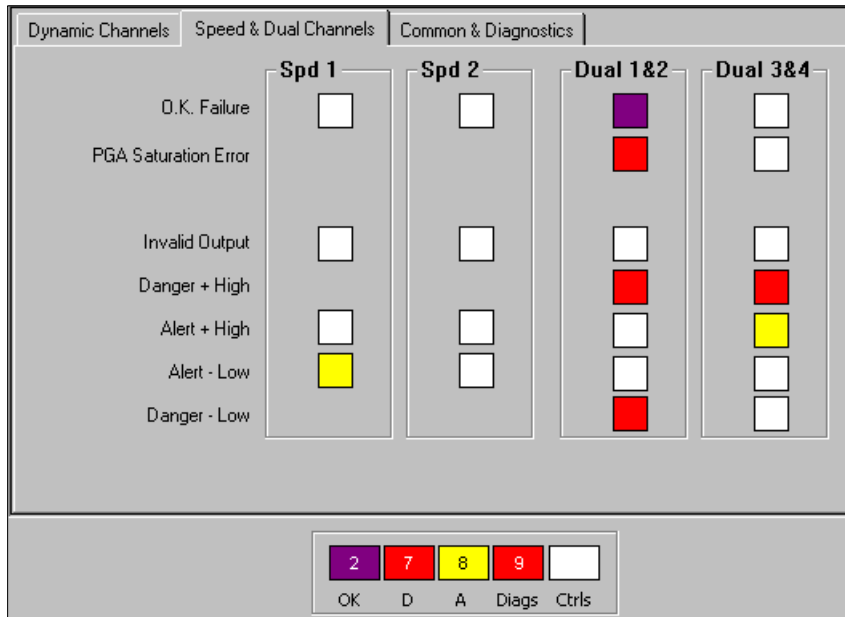

**Figure 11-7:** Read Status Latch Data window (Speed & Dual Channels tab)

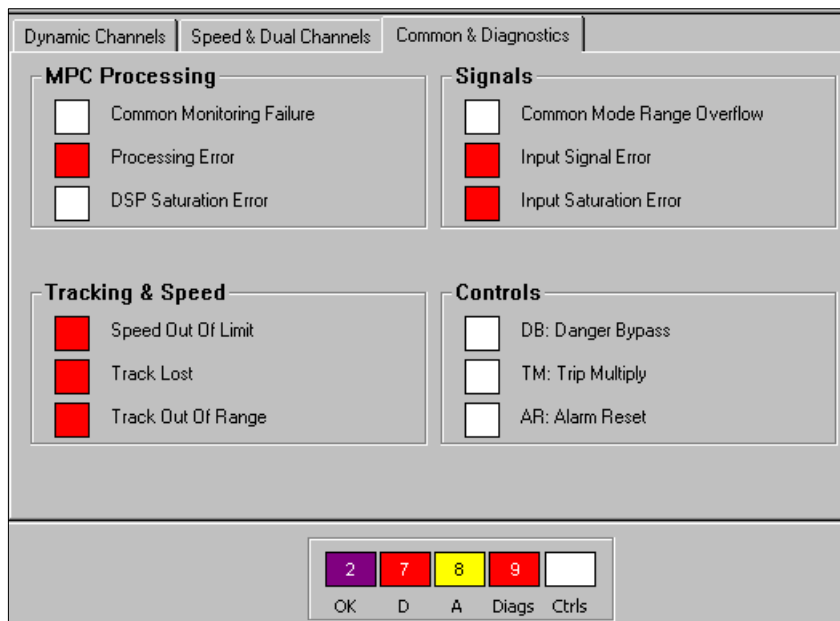

**Figure 11-8:** Read Status Latch Data window (Common & Diagnostics tab)

## 11.8 The MPC outputs window (Read Outputs)

The MPC Outputs window (Figure 11-9) shows detailed information concerning measured values, such as speed, vibration levels, alarms, hardware and software status. The window is called up by selecting **From MPC** from the **Communications** menu and then choosing the **Read Outputs** command.

Measurements can be obtained in two ways:

- 1- A single acquisition can be made, providing a “snapshot” of the machine status at a given moment in time.  
To do this, click the **Get Outputs** button (Figure 11-10). The button to the right of this one should read **Poll Outputs** (indicating continuous acquisitions are presently disabled).
- 2- A continuous series of acquisitions can be made. The period between successive acquisitions is fixed at 1.0 second.  
To do this, click the **Poll Outputs** button (Figure 11-10). The text on the button changes to “**End Polling**” when this is done. Click the **End Polling** button to stop acquiring data.

To end the session, click the **Done** button.

### 11.8.1 Explanation of fields

The MPC Outputs window can be broken down into the following areas for the purposes of this explanation:

- 1- Fields concerning the two speed channels (see Figure 11-11)
- 2- Fields concerning the four single measurement channels (see Figure 11-12)
- 3- Fields concerning the two dual measurement channels (see Figure 11-13)
- 4- Fields concerning the basic and advanced logical combinations of alarms (see Figure 11-14)
- 5- Fields concerning status information (see Figure 11-15)

The **MPC Running** indicator (see Figure 11-11) has the following behaviour:

- It flashes green/white alternately when the configuration is running.
- It is continually red when the configuration is not running.  
When this occurs, it is often due to an incorrect configuration. It may also occur during the MPC4 card's warm-up period.

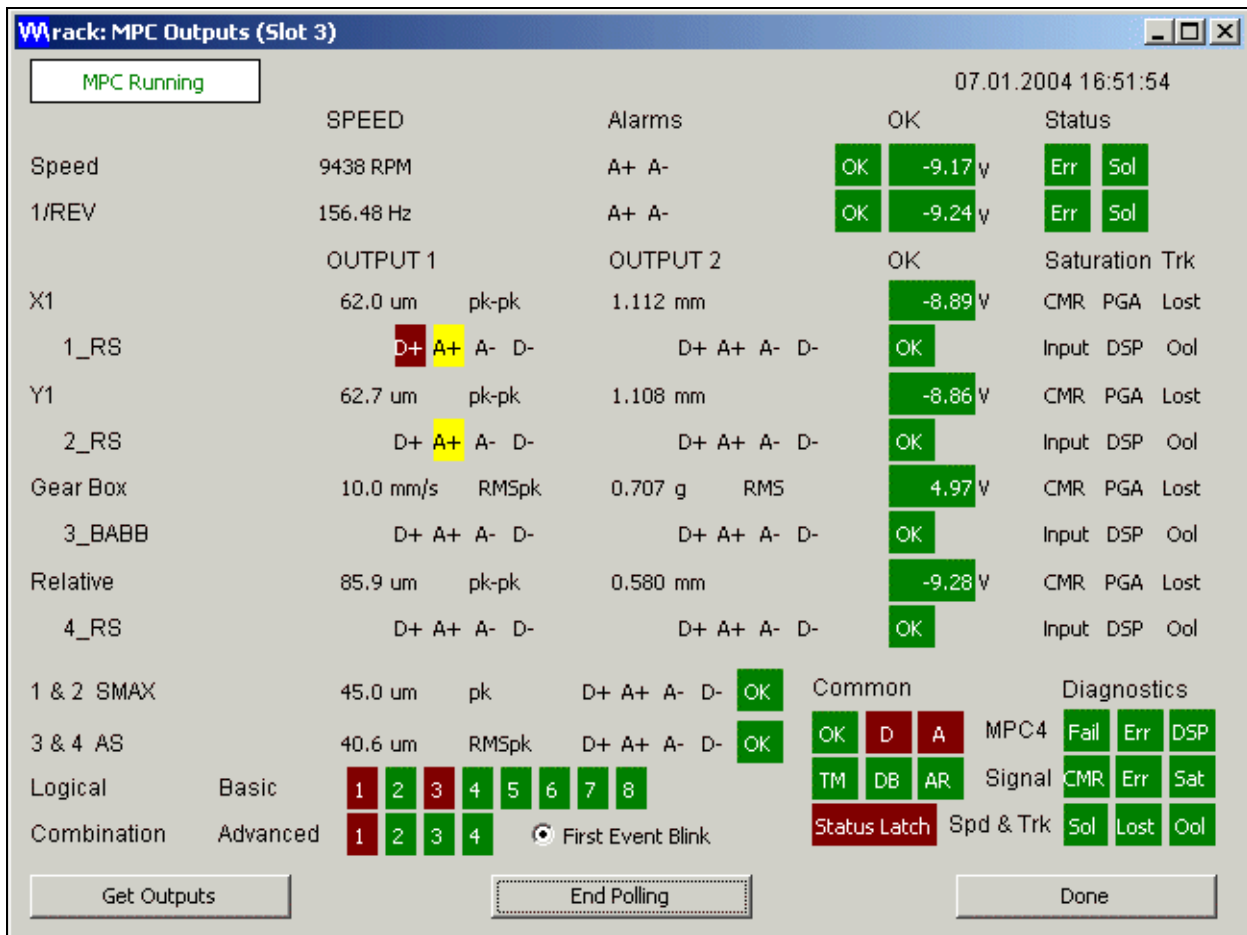

Figure 11-9: Typical MPC Outputs window



Figure 11-10: Get Outputs and Poll Outputs buttons

### 11.8.1.1 Fields concerning the two speed channels

The MPC Outputs window shows the measured values and alarm status for the two speed channels (Figure 11-11).

The first column indicates the sensor tag entered for each channel.

The speed values are shown in the units selected. The following colour coding applies:

- Grey, indicating the value is within limits
- Red, indicating the full scale has been exceeded
- Purple, indicating the value is not valid due to a hardware/software error
- ??????, indicating the output is not configured.

The Alert+ (A+) and Alert- (A-) alarm flags indicate when the speed is in/out of limits. The following colour coding applies:

- Grey, indicating the value is within OK limits
- Yellow, indicating the value is out of OK limits.

The OK values (expressed in V or mA) are the DC values extracted from the signals. The following colour coding applies to the OK values and the OK level flags:

- Green, indicating the value is within OK limits
- Red, indicating the value is out of OK limits.

The status flags have the following meaning:

- Sol** Speed out of limits.  
Limits are 0.017 Hz to 1092 Hz.  
This can be because the machine is really in an overspeed condition. Another reason may be that the tachometer signal is dirty and this causes additional pulses which the MPC misinterprets as being due to a high speed.
- Err** Channel error or failure.  
This may be caused by a signal error or an MPC error for this channel.

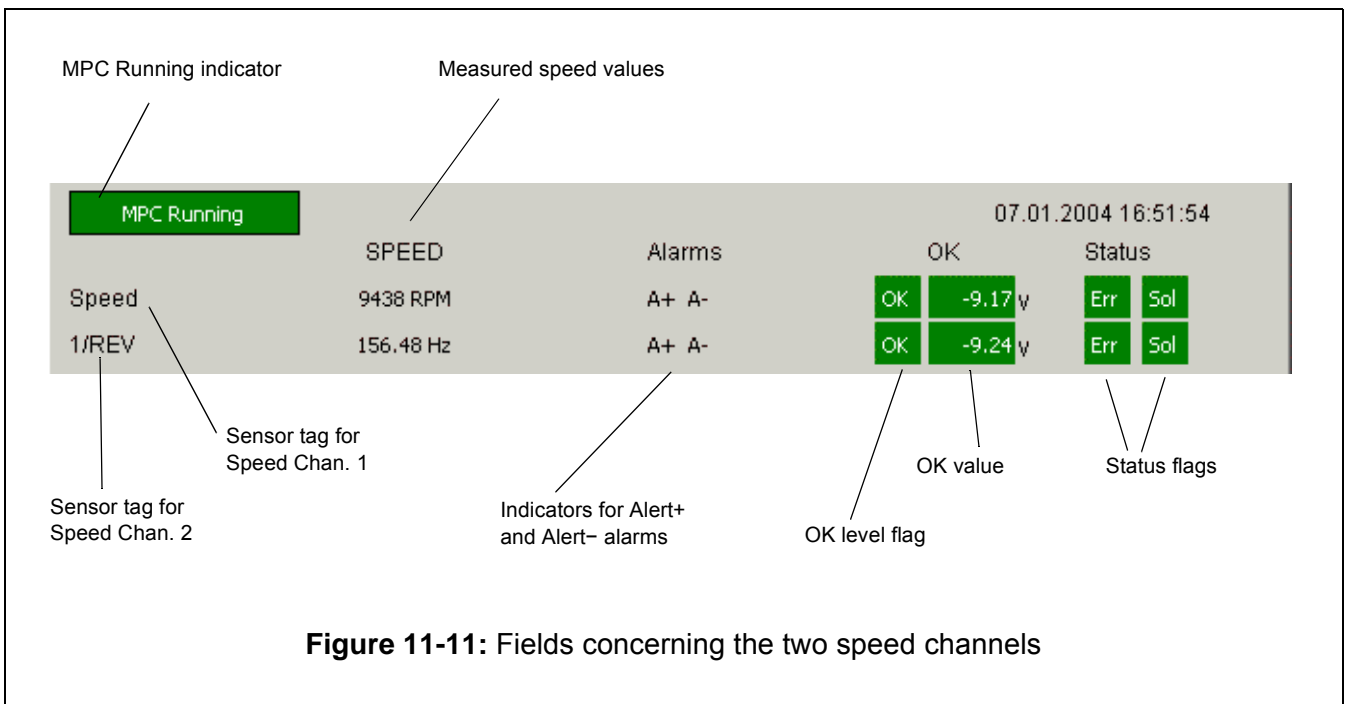

### 11.8.1.2 Fields concerning the four single measurement channels

The MPC Outputs window shows measured values and alarm status for the four single measurement channels (Figure 11-12).

The first column indicates the sensor tag entered for each channel.

The measured values are shown in the units selected by the user. The following colour coding applies:

- Grey, indicating the value is within limits
- Red, indicating the full scale has been exceeded
- Purple, indicating the value is not valid due to a hardware / software error
- ??????, indicating the output is not configured.

The Alert+ (A+) and Alert- (A-) alarm flags indicate when the measured value is in/out of Alert limits. The following colour coding applies:

- Grey, indicating the value is within Alert limits
- Yellow, indicating the value is out of Alert limits.

The Danger+ (D+) and Danger- (D-) alarm flags indicate when the measured value is in/out of Danger limits. The following colour coding applies:

- Grey, indicating the value is within Danger limits  
(NB: The value may nevertheless be out of Alert limits)
- Red, indicating the value is out of Danger limits.

The OK values (expressed in V or mA) are the DC values extracted from the signals. The following colour coding applies to the OK values and the OK level flags:

- Green, indicating the value is within OK limits
- Red, indicating the value is out of OK limits.

The status flags have the following meaning:

In the "Saturation" group:

CMR: Out of Common Mode Range ( $\pm 50V$ )

This may happen if a sensor wire is cut, or if the EMC requirements are not fulfilled at the site where the VM600 MPS is installed.

PGA: Saturation of programmable gain amplifier

In this case the signal dynamic and/or FSD must be increased when an integration (or double integration) is required.

Input: Saturation at input amplifier (first stage)

This occurs if the signal contains spurious spikes or is in over-range (above  $\pm 20 V$ ).

DSP: Saturation of calculation in the Digital Signal Processor

This is due to a configuration that isn't adapted to the signal. It may be remedied by increasing the FSD as well as the input signal dynamic.

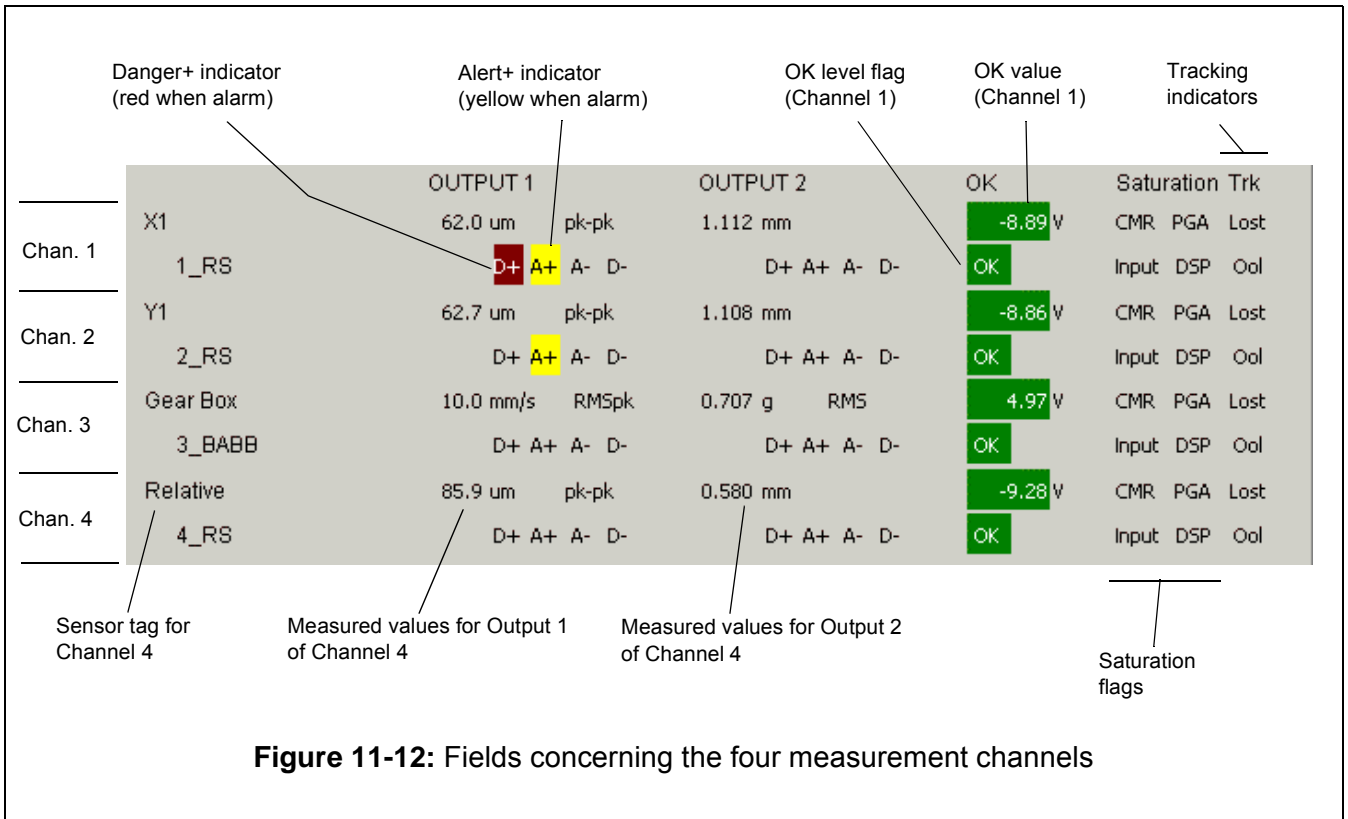

Figure 11-12: Fields concerning the four measurement channels

In the "Tracking" group:

- Ool** Tracking is out of limits. The tracking speed for this channel has exceeded the range defined in the Narrow Band configuration. This may be due to a dirty signal. Otherwise the range may be increased (respecting the restrictions described in this manual).
- Lost** The tracking has been lost. This may occur if the speed is out of limits or if the speed changes too quickly for the processing to follow it. The tachometer signal must be checked.

**NOTE:** The Tracking **Ool** and Tracking **Lost** flags are relevant only to Narrow Band (Tracking) processing.

### 11.8.1.3 Fields concerning the two dual measurement channels

The MPC Outputs window shows measured values and alarm status for the two dual measurement channels (Figure 11-13).

The measured values are shown in the units selected by the user. The following colour coding applies:

- Grey, indicating the value is within limits
- Red, indicating the full scale has been exceeded
- Purple, indicating the value is not valid due to a hardware/software error
- ??????, indicating the output is not configured.

The Alert+ (A+) and Alert- (A-) alarm flags indicate when the measured value is in/out of Alert limits. The following colour coding applies:

- Grey, indicating the value is within Alert limits
- Yellow, indicating the value is out of Alert limits.

The Danger+ (D+) and Danger- (D-) alarm flags indicate when the measured value is in/out of Danger limits. The following colour coding applies:

- Grey, indicating the value is within Danger limits (NB: The value may nevertheless be out of Alert limits)
- Red, indicating the value is out of Danger limits.

The OK level flags have the following colour coding:

- Green, indicating the value is within OK limits
- Red, indicating the value is out of OK limits.

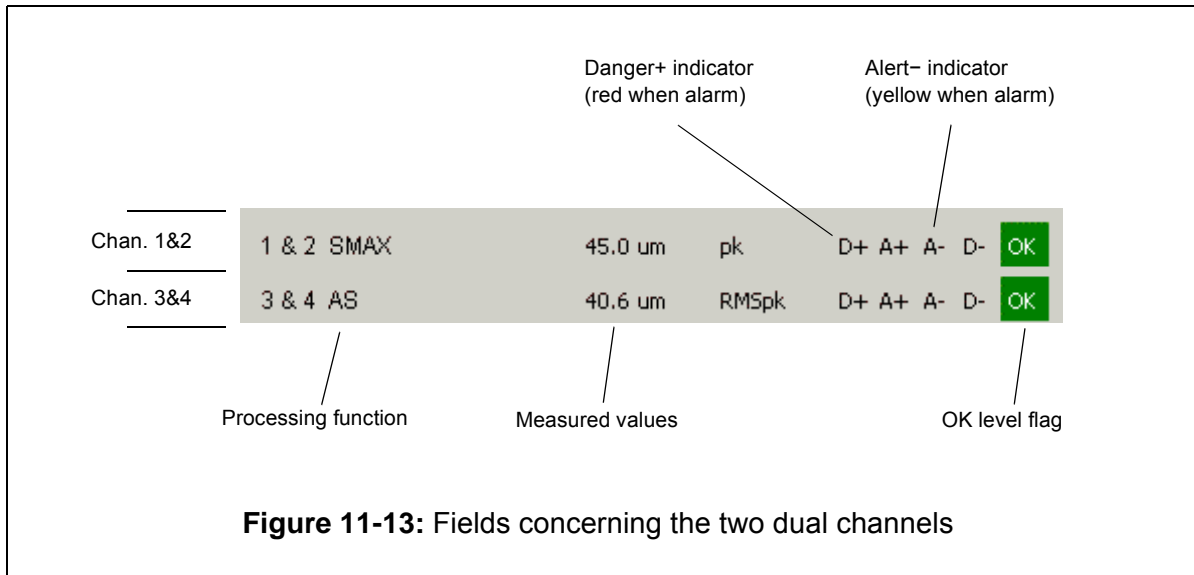

11.8.1.4 Fields concerning basic and advanced logical combinations of alarms

The MPC Outputs window shows the status of the eight Basic and four Advanced logical combinations of alarms (Figure 11-14).

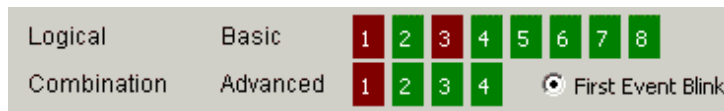

**Figure 11-14: Fields concerning the basic and advanced logical combinations of alarms**

The alarm flags have the following colour coding:

- Green, indicating there is no alarm
- Red, indicating an alarm.

11.8.1.5 Fields concerning status information

The MPC Outputs window shows information on common alarms as well as status information for diagnostics purposes (see Figure 11-15).

Table 11-3 summarises the meaning of the flags in the "Common" group.

Table 11-2: Flags in the "Common" group

Flag name	Description	Colour coding
Common OK	Common OK level alarm	Green: indicating no Common Alert, Common Danger or Common OK level alarm.
Common D	Common Danger level alarm	
Common A	Common Alert level alarm	Red: indicating an alarm.
Common TM	Trip Multiply indicator	Green: indicating TM, DB or AR is not active.
Common DB	Danger Bypass indicator	
Common AR	Alarm Reset indicator	Red: indicating TM, DB or AR is active.

The **Status Latch** flag (see Figure 11-15 and 11.7 The status latch (clearing and reading)) has the following colour coding:

- Green, indicating no data has been latched since the last Clear Status Latch Data operation
- Red, indicating data has been latched.

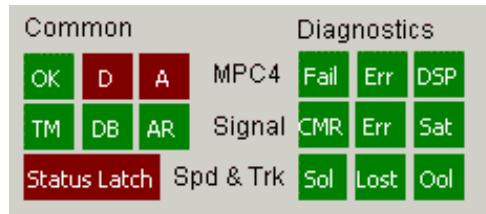

Figure 11-15: Fields concerning status information

Table 11-3 summarises the meaning of the flags in the "Diagnostics" group. These all have the following colour coding:

- Green, indicating no error/failure detected
- Red, indicating error/failure detected.

**Table 11-3:** Flags in the “Diagnostics” group

Flag name	Description
On the “MPC4” line:	
Fail	Common flag for monitoring failure. The result is that at least one of the output values no longer generates alarms.
Err	Common flag for processing error. This is due to any error in at least one of the channels.
DSP	Common flag for DSP saturation error. The configuration must be checked, particularly the FSD and input signal dynamic.
On the "Signal" line:	
CMR	Common flag for “Out of Common Mode Range” error. See the description of "CMR" in 11.8.1.2 Fields concerning the four single measurement channels.
Err	Common flag for input signal error. Check the signal range and that there are no spikes on the signal.
Sat	Common flag for input saturation error. This may be due to saturation of the input amplifier (first stage) or the programmable gain amplifier (PGA). See the descriptions of “Input” and “PGA” in 11.8.1.2 Fields concerning the four single measurement channels.
On the “Spd & Trk” (Speed and Tracking) line:	
Sol	Common flag for speed out of limits. See the description of “Sol” in 11.8.1.1 Fields concerning the two speed channels.
Lost	Common flag for tracking lost. See the description of “Lost” in 11.8.1.2 Fields concerning the four single measurement channels.
Ool	Common flag for tracking out of limits. See the description of “Ool” in 11.8.1.2 Fields concerning the four single measurement channels.

### 11.8.1.6 First Event Blink and Scan Rate

When activated, the First Event Blink feature allows the user to check which event occurred first among several. It takes into consideration all MPC channels.

The feature is activated by clicking the **First Event Blink** button on the MPC Outputs window (see Figure 11-14).

Users must bear in mind that an event which occurs between two scans and has a duration of less than the period between successive scans will not be seen on the MPC Outputs window. The time resolution (interval between successive scans) is fixed at 1.0 second. The event is only detected if it creates a Status Latch event. In this case, the Status Latch indicator on the MPC Outputs window (see Figure 11-15) becomes red. Further information on the event can be obtained by performing a Read Status Latch Data operation (see Figure 11.7).

### 11.9 Resetting alarms (Alarm Reset)

Alarms indicated by the status indicators (LEDs) on the front panel of the MPC4 card, or on the MPC Outputs window, can be reset by selecting **To MPC** from the **Communications** menu and then choosing the **Alarm Reset** command.

### 11.10 Checking the card status (Read System Status)

This menu command is mainly provided for troubleshooting purposes. In case of problems with a card, Meggitt Sensing Systems customer support may ask you to pass on to them certain information available from the VM600 MPS software (see Figure 11-16).

To view the card status, select **From MPC** from the **Communications** menu and then select the **Read System Status** command.

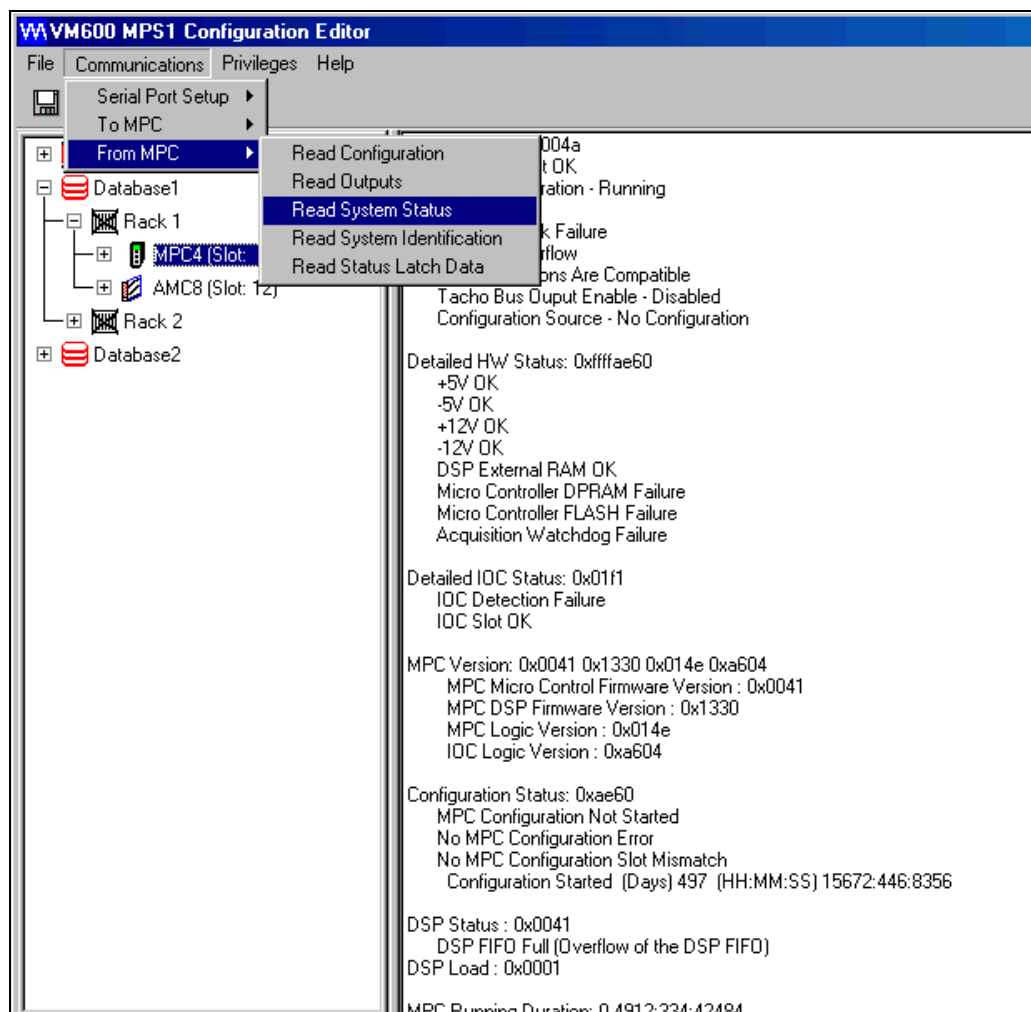

Figure 11-16: Read System Status window

## 11.11 Inhibiting a channel (Channel Inhibits)

The channel inhibit function allows individual MPC4 input channels (measurement and speed) and the processing associated with them to be temporarily bypassed.

The channel inhibit function is activated when one of the VM600 MPS software packages (MPS1 or MPS2) is used to send channel inhibit commands to individual MPC4 input channels. Alternatively, can be used to control the channel inhibit function for networked VM600 machinery protection systems (containing a CPUM card).

To activate the channel inhibit function for an MPC4 input channel or channels:

- 1- Click **Communications > To MPC > Channel Inhibits**.
- 2- Use the Channel Inhibits dialog box that appears to select the Measurement Channels and Speed Channels for which the channel inhibit function is required. Then click **Send**.  
The channel inhibit function is activated for the selected channels.

When the channel inhibit function is activated for a channel:

- Any processing channels that depend on the channel are also automatically bypassed.
- The power supply for the channel is turned off.
- An Inhibit On event is recorded in the database.
- The MPC outputs window displays the channel information with an “Inhibited” label and in grey coloured text (see 11.8 The MPC outputs window (Read Outputs)).
- The channel’s status indicator (LED) on the front panel of the MPC4 card slowly blinks green for the duration of the channel inhibit (approximately once per second).

Also, clicking **Communications > To MPC > Channel Inhibits** again will display the Channel Inhibits dialog box with the check boxes selected for each inhibited input channel.

---

**NOTE:** When an MPC4 card is configured (for example, using **Communications > To MPC > Send Configuration**), the channel inhibit function is automatically deactivated for any channels where it is active.

---

To de-activate the channel inhibit function for an MPC4 input channel or channels:

- 1- Click **Communications > To MPC > Channel Inhibits**.
- 2- Use the Channel Inhibits dialog box that appears to clear the Measurement Channels and Speed Channels for which the channel inhibit function is no longer required. Then click **Send**.  
The channel inhibit function is de-activated for the cleared channels.

When the channel inhibit function is de-activated for a channel:

- The power supply for the channel is turned back on and the MPC4 card waits 2 seconds for signal stabilisation (in addition to the OK system check recovery time).
- Any latched alarms are reset (cleared) and the processing channels that depend on the channel resume normal operation.
- An Inhibit Off event is recorded in the database.

- The MPC outputs window displays the channel information as usual (see 11.8 The MPC outputs window (Read Outputs)).
- The channel's status indicator (LED) on the front panel of the MPC4 card indicates the operational status of the card.

---

**NOTE:** Cards that support the channel inhibit function can coexist in a VM600 rack with cards (running older versions of firmware) that do not support this function. For cards that do not support the channel inhibit function, the VM600 MPS software will report the channel inhibit function as unavailable.

---

**THIS PAGE INTENTIONALLY LEFT BLANK**

# Part IV: Configuring AMC8 cards

**THIS PAGE INTENTIONALLY LEFT BLANK**

## 12 CONFIGURING INPUTS AND PROCESSING FUNCTIONS (AMC8)

### 12.1 Introduction

This section describes the **Inputs / Processing** branch of the configuration tree structure that is visible when an AMC8 card is selected (see Figure 12-1). This branch allows sensor characteristics for the eight single channels and four “multi-channels” to be configured. Signal processing parameters and alarm levels are also defined here.

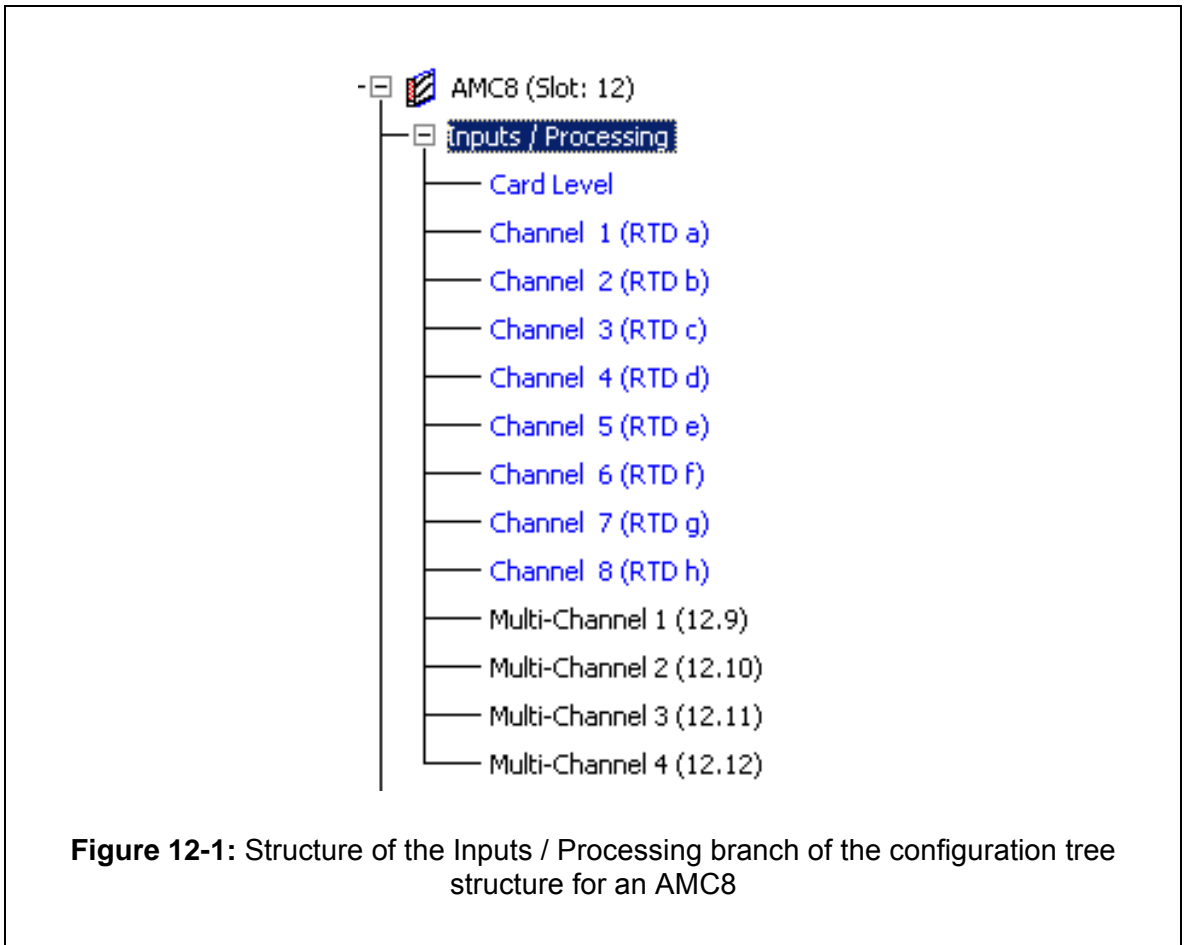

**Figure 12-1:** Structure of the Inputs / Processing branch of the configuration tree structure for an AMC8

## 12.2 Configuration of general parameters at card level

Select **Card Level** from the configuration tree structure to obtain a window resembling that shown in Figure 12-2.

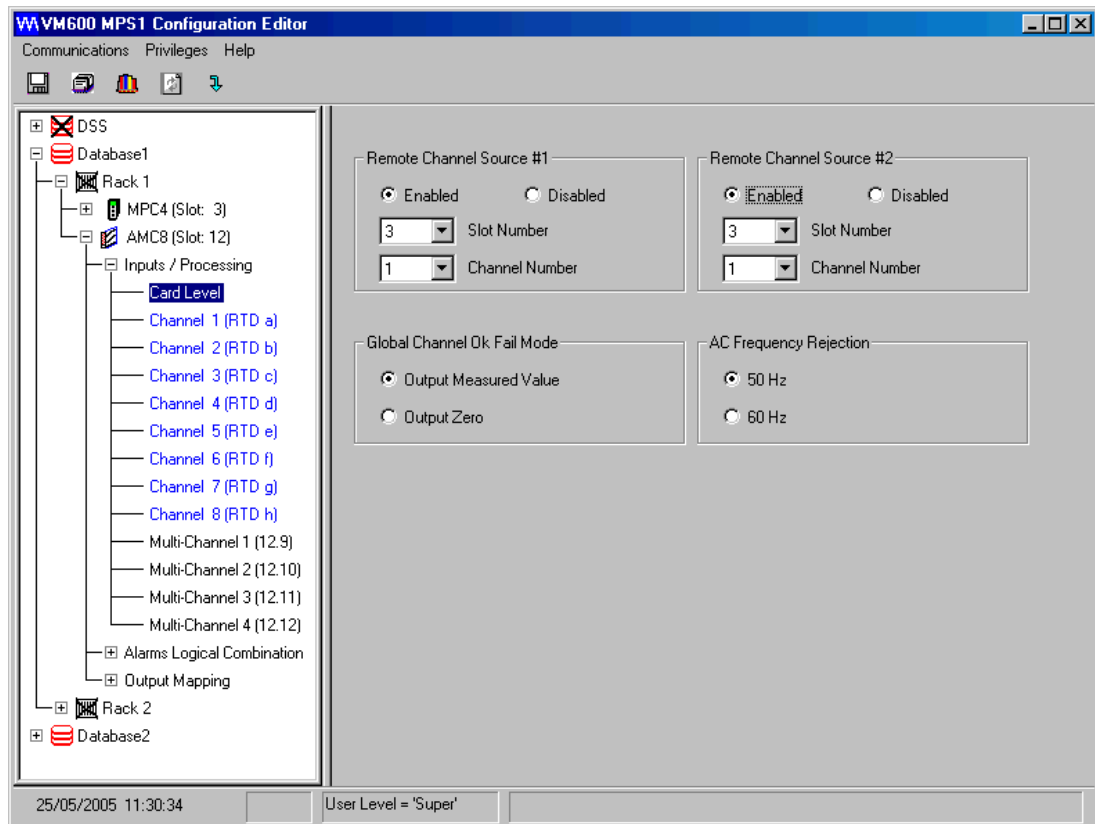

**Figure 12-2:** Window when Card Level is selected in the configuration tree structure

### 12.2.1 General description

This window (Figure 12-2) contains the following fields:

**1- Remote Channel Source #1 and #2**

See 12.2.2 Using remote channels.

**2- Global Channel OK Fail Mode**

The setting of these radio buttons determines how measured data is presented on the AMC Outputs window (see 15 Communications menu (AMC8)) in the event of a Global Channel OK Fail.

- If **Output Measured Value** is selected, the actual measured value is displayed.

---

**NOTE:** Bear in mind that this value may be meaningless and maybe should not be taken into consideration.

---

- If **Output Zero** is selected, a numerical value of 0 is displayed.

**3- AC Frequency Rejection**

This feature provides narrow-band rejection of signals at either 50 Hz or 60 Hz (to filter out unwanted noise coming from the mains network). Click the applicable radio button to select the frequency you want to reject.

## 12.2.2 Using remote channels

The Remote Channel Source feature allows a “cold junction” (CJ) temperature signal (generally obtained using an RTD device) to be routed from one card to another in the rack. Up to two remote channel sources can be defined for a given rack.

### Configuration Example:

An AMC8 card in slot 6 of the rack is used to obtain two “cold junction” temperature signals, using channels 7 and 8 of the card. The operator wants to define these signals as Remote Channel Source #1 and Remote Channel Source #2, respectively. This information should be entered on the Board Level window using the **Slot Number** and **Channel Number** fields, as shown in Figure 12-2.

**NOTE:** When entering this information, the software does not actually check that there is an AMC8 card installed in the slot (slot 6). You should check that the slot really contains an AMC8 card (not an MPC4 card) and that the channel number provides a meaningful temperature signal.

Once a remote channel source has been defined it can be used by other cards in the rack. Continuing the example above, if the operator wants to use a remote signal for cold junction compensation of channel 1 of the AMC8 card installed in slot 4 he should proceed as follows:

- 1- Select **Channel 1 (RTD a)** from the **Inputs / Processing** branch of the tree structure for the AMC8 card in slot 4.
- 2- Select **TC** in the **Sensor Family** field.
- 3- Select **Remote Channel 1** in the **CJT Source** field, as shown in Figure 12-3

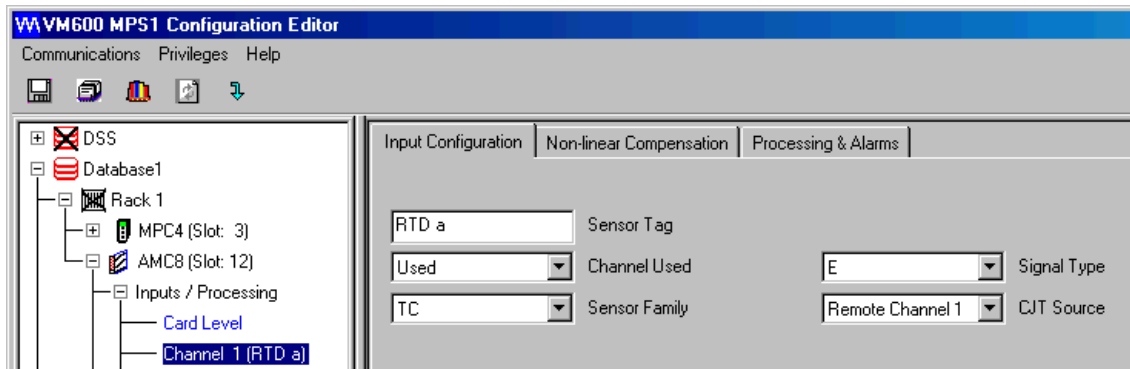

Figure 12-3: Defining Remote Channel 1 as the CJT source

## 12.3 Configuring single channels

A window resembling that shown in Figure 12-4 appears when one of the eight single channels (Channel 1 to Channel 8) is selected in the configuration tree structure. The window has three tabs:

- **Input Configuration**
- **Non-linear Compensation**
- **Processing & Alarms.**

### 12.3.1 The input configuration tab

The appearance of the Input Configuration tab (fields present) depends on what type of sensor is selected in the **Sensor Family** field (see Figure 12-4, Figure 12-6 and Figure 12-8).

#### 12.3.1.1 General

To configure a channel, see Figure 12-4 and proceed as follows:

- 1- Select the sensor type from the **Sensor Family** field. The choices are:
 

<b>U</b>	for voltage-based sensors.
<b>I</b>	for current-based sensors.
<b>TC</b>	for thermocouples.
<b>RTD</b>	for Resistance Temperature Devices.
- 2- From the **Input Sensor Range** combo box, select the range that most closely matches that delivered by your sensor.
- 3- For linear devices, click the **Linear** radio button under **Sensor Compensation Type**.  
For non-linear devices, the **Non-linear** button must be clicked. This enables the user to enter values on the Non-linear Compensation tab. See 12.3.2 The non-linear compensation tab for further information.

---

**NOTE:** The Non-linear Compensation tab is unavailable (dimmed) when the **Linear** radio button is selected.

---

- 4- Enter the sensor characteristics under **Linear Compensation**.  
The value of the signal at a temperature of zero must be entered in the **Offset** field.  
The offset and sensitivity can be entered as normal decimal numbers, but the software displays them in scientific notation. For example:
 

-1	is displayed as -1.00000000E+00.
20	is displayed as 2.00000000E+01.

  
 Note that the “Converted range” text changes as a function of what is entered in the **Offset** and **Sensitivity** fields.
- 5- Enter values in the **OK Level Upper Value** and **OK Level Lower Value** fields. The equivalent temperatures are displayed (dimmed) to the right of these fields.
- 6- Enter a name for the sensor in the **Tag** field and set the **Sensor Connected** field to Yes.
- 7- Click the **Save** icon on the toolbar to save the configuration in memory.

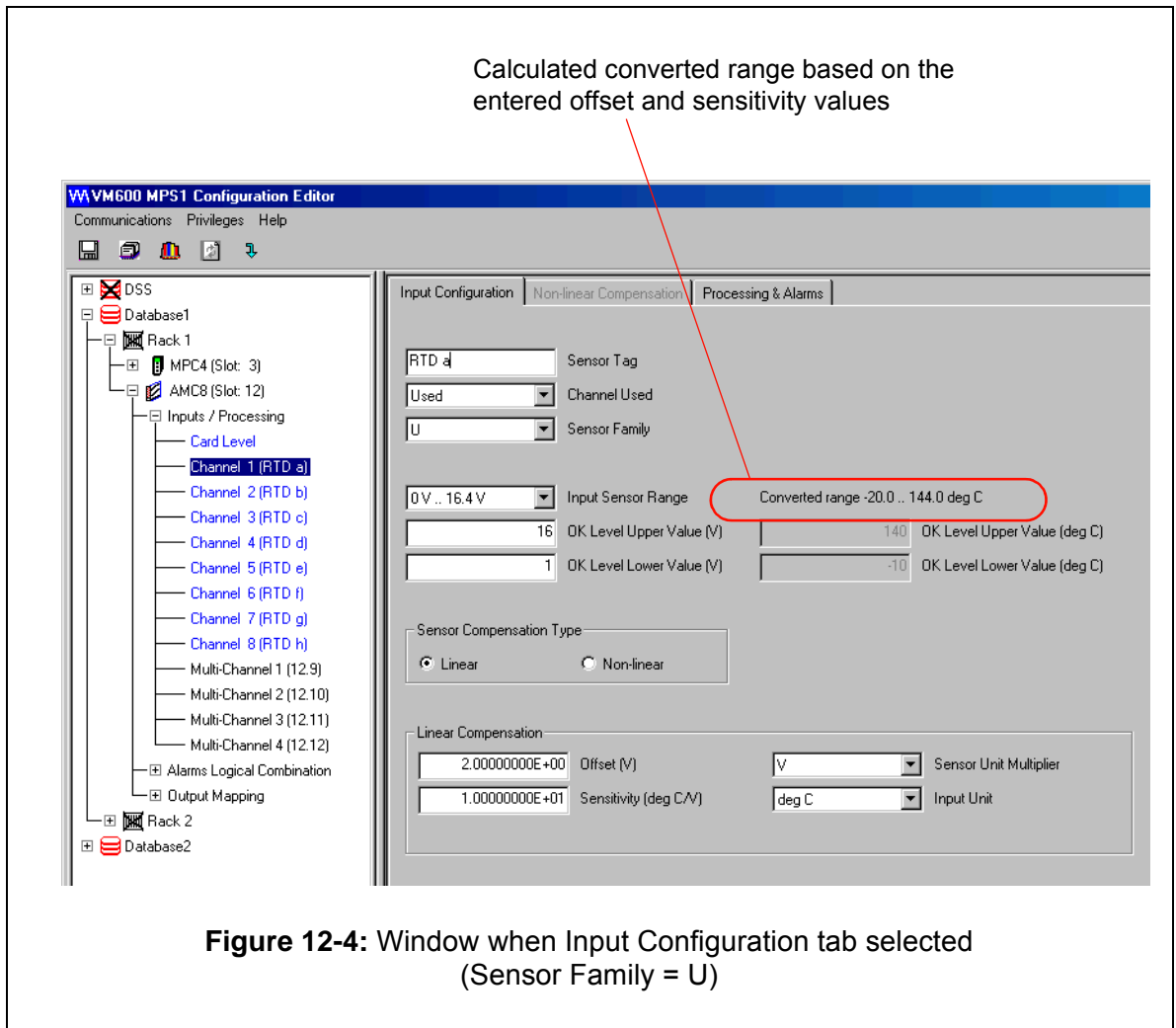

### 12.3.1.2 Example for a voltage-based sensor

Assume that a sensor outputs a voltage according to the graph in Figure 12-5.

The output voltage is linear with temperature, so the **Linear** radio button must be selected. The **Linear Compensation** area appears at the bottom of the tab when this is done (Figure 12-4).

Set the **Sensor Unit Multiplier** field to “V” and the **Input Unit** field to “deg C” (giving a sensitivity in units of °C/V).

The sensor outputs a voltage of 2.0 V at a temperature of 0°C. The **Offset** field should therefore be set to 2.0 (this is displayed as 2.00000000E+00).

The sensitivity is 10°C/V, so the **Sensitivity** field should be set to 10 (this is displayed as 1.00000000E+01).

These settings lead to a converted range of –20 to 144°C (corresponding to 0 to 16.4 V)

Setting the OK levels to 1 V and 16 V means that temperatures in the range –10 to 140°C are considered as valid.

The window setup for this example is shown in Figure 12-4.

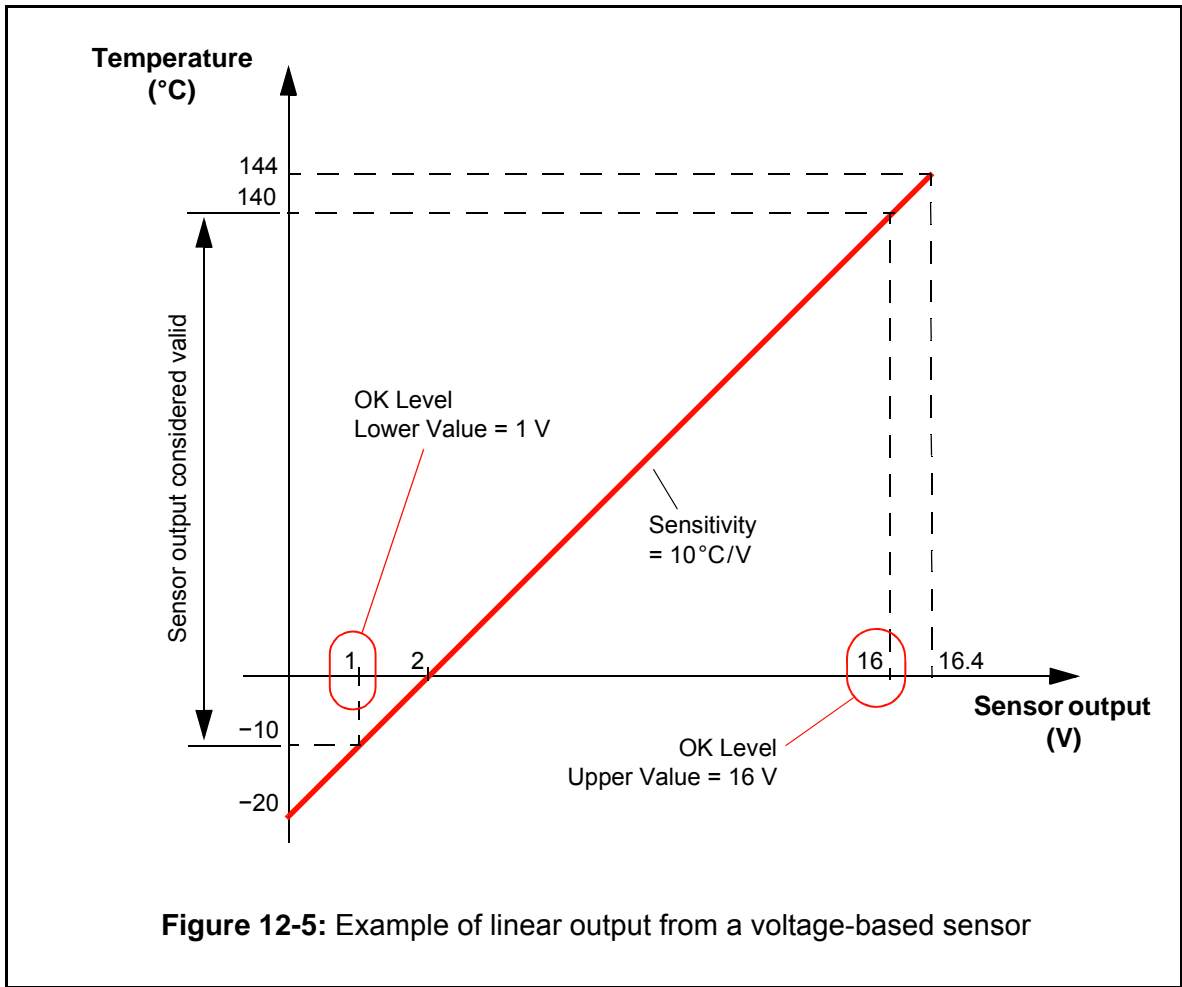

Figure 12-5: Example of linear output from a voltage-based sensor

**NOTE:** The setup procedure for a linear current-based sensor is very similar to that described in this section.

### 12.3.1.3 Configuration window for thermocouples

A window resembling Figure 12-6 appears when a thermocouple (TC) is selected in the **Sensor Family** field.

Select the type of thermocouple in the **Sensor Type** field. Possible choices are “E”, “J”, “K”, “T” or “User Defined”.

The **Sensor Compensation Type** is set to **Non-linear** by default. The linearising coefficients can be examined in read-only mode (dimmed) by clicking the Non-linear Compensation tab (see Figure 12-7). You should not set the **Sensor Compensation Type** to “Linear”.

If the **Sensor Type** field is set to User Defined, the data on the Non-linear Compensation tab becomes editable. See 12.3.2 The non-linear compensation tab for information on configuring this tab.

If cold junction compensation is required, the source device must be selected in the **CJT Source** field. The source can be one of eight local channels (Local Channel 1 to Local Channel 8) or one of two remote channels (Remote Channel 1 or Remote Channel 2). See 12.2.2 Using remote channels for information on remote channels.

The other fields should be configured as described in 12.2.1 General description.

When setting the OK levels, the converted temperature value is replaced by a yellow box if the voltage value lies outside the conversion range. The conversion range can be found on the Non-linear Compensation tab as shown in Figure 12-7.

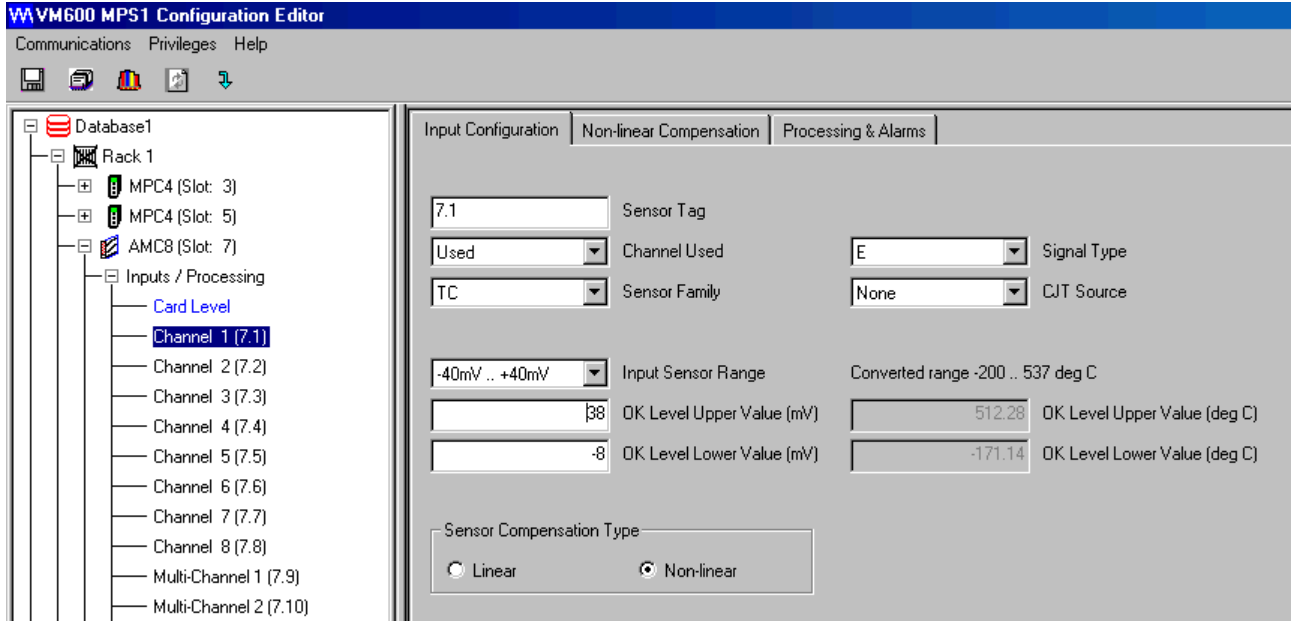

**Figure 12-6:** Window when Input Configuration tab selected (Sensor Family = TC)

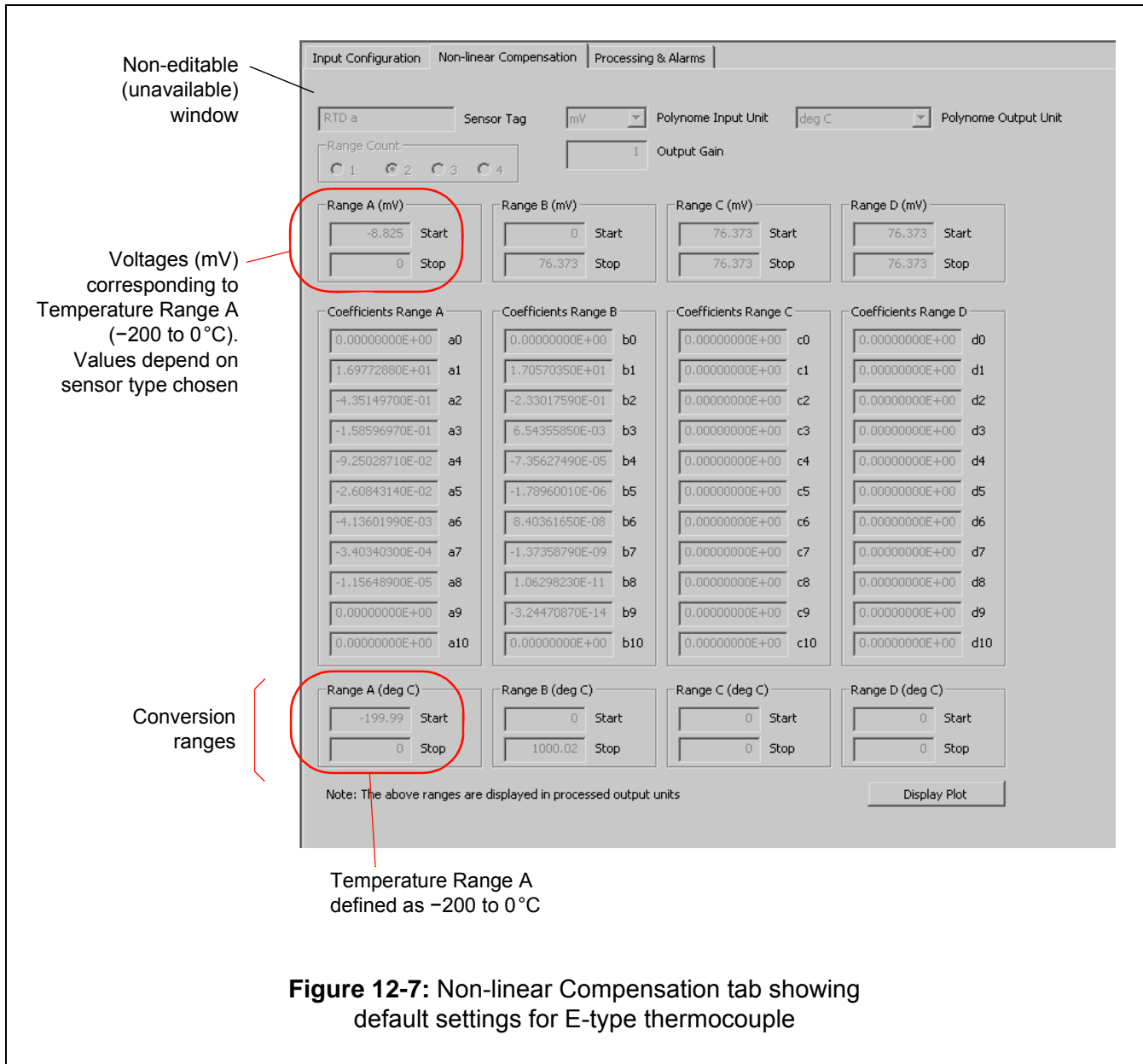

**12.3.1.4 Configuration window for RTD devices**

A window resembling Figure 12-8 appears when a RTD device is selected in the **Sensor Family** field.

Select the type of RTD in the **Sensor Type** field. Possible choices are Pt100 (0.00385), Pt100 (0.00392), Cu10 (0.00427), Ni120 (0.00672) or User Defined.

Select the hardware configuration (2-wire, 3-wire or 4-wire arrangement) in the **Sensor Connection Type** field.

**NOTE:** Refer to the *VM600 Machinery Protection System (MPS)* hardware manual for further information on hardware configurations.

The **Sensor Compensation Type** is set to **Non-linear** by default. The linearising coefficients can be examined in read-only mode (dimmed) by clicking the **Non-linear Compensation** tab

(the resulting tab resembles somewhat that shown in Figure 12-7). You should not set the **Sensor Compensation Type** to **Linear**.

If the **Sensor Type** field is set to “User Defined”, the data on the Non-linear Compensation tab becomes editable. See 12.3.2 The non-linear compensation tab for information on configuring this tab.

The other fields should be configured as described in 12.2.1 General description.

When setting the OK levels, the converted temperature value is replaced by a yellow box if the resistance value lies outside the conversion range. The conversion range can be found on the Non-linear Compensation tab (see Figure 12-7).

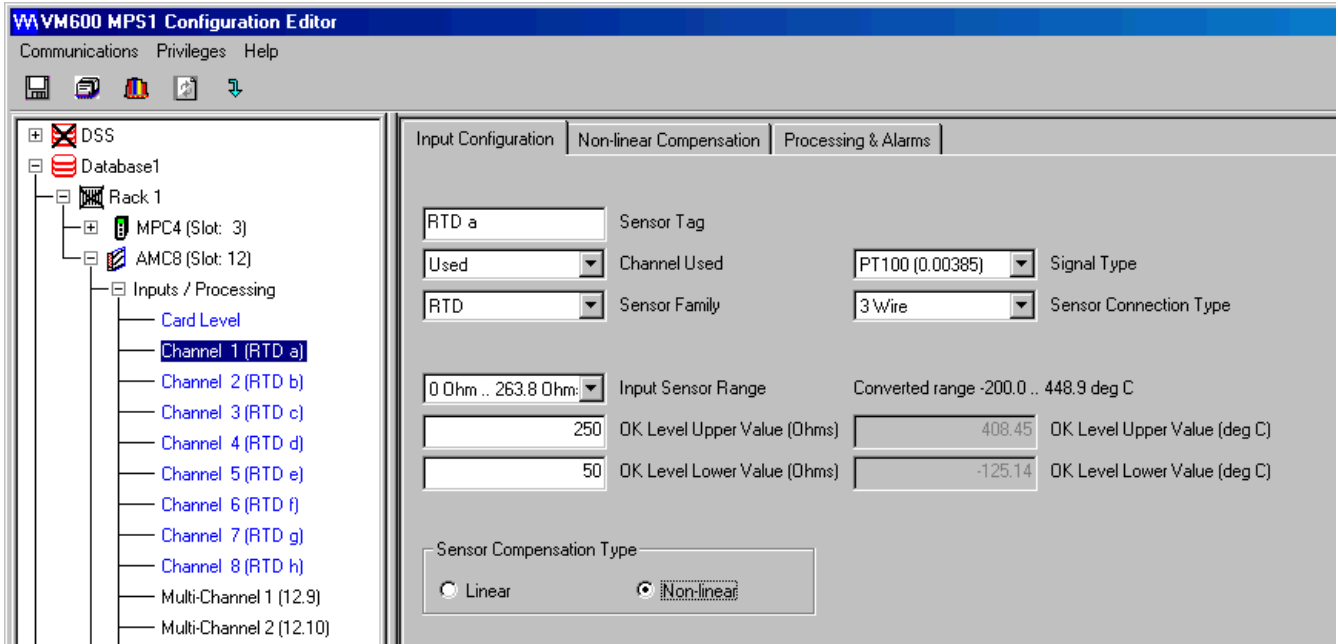

**Figure 12-8:** Window when Input Configuration tab selected  
(Sensor Family = RTD)

### 12.3.2 The non-linear compensation tab

The Non-linear Compensation tab (Figure 12-12) can be viewed but not edited when a standard sensor type is chosen on the Input Configuration tab. This includes the following configurations:

- Sensor Family = TC, with Sensor Type = E, J, K or T
- Sensor Family = RTD, with Sensor Type = Pt100, Cu10 or Ni120

To edit the Non-Linear Compensation tab you must first have one of the following set up on the Input Configuration tab:

- The **Sensor Family** field set to U (voltage-based sensor) or I (current-based sensor) and the **Non-linear** button selected under **Sensor Compensation Type**.
- or
- The **Sensor Family** field set to TC (thermocouple) or RTD, the **Sensor Type** field set to User Defined and the **Non-linear** button selected under **Sensor Compensation Type**.

### 12.3.2.1 Polynomial coefficients

The Non-linear Compensation tab allows a polynomial equation to be applied to a particular range of the curve that defines the relationship between the input quantity (such as a voltage, current or resistance value) and the output quantity (such as temperature).

The polynomial equation contains polynomial coefficients and has the following form:

$$y = p_0 + p_1 \cdot x + p_2 \cdot x^2 + p_3 \cdot x^3 \dots + p_n \cdot x^n$$

where

x = the input variable

y = the linearised and scaled output

$p_n$  = the polynomial coefficients (the value of "n" is the order of the polynomial)

Each polynomial has its set of coefficients, and each sensor (TC or RTD) has its own set of polynomials.

The choice of polynomial order (the value of "n" in the equation above) has an influence on the accuracy of the linearisation process and the computing power needed to perform the calculation. The higher the order, the greater the temperature range over which the polynomial equation can apply, but the longer it takes to calculate the value because of the extra processing power required.

The entire measuring range can be split into two or more sub-ranges, where each sub-range has its own polynomial equation (see Figure 12-9). This technique allows polynomials having a lower order to be used.

A polynomial must only be used over its valid input variable range, otherwise significant measurement errors can arise.

The point where polynomials change (for example, where Range A meets Range B in Figure 12-9) should be chosen with care to avoid significant discontinuities in the calculated value.

---

**NOTE:** Software packages for calculating the best polynomials and optimum number of sub-ranges for your application are commercially available.

---

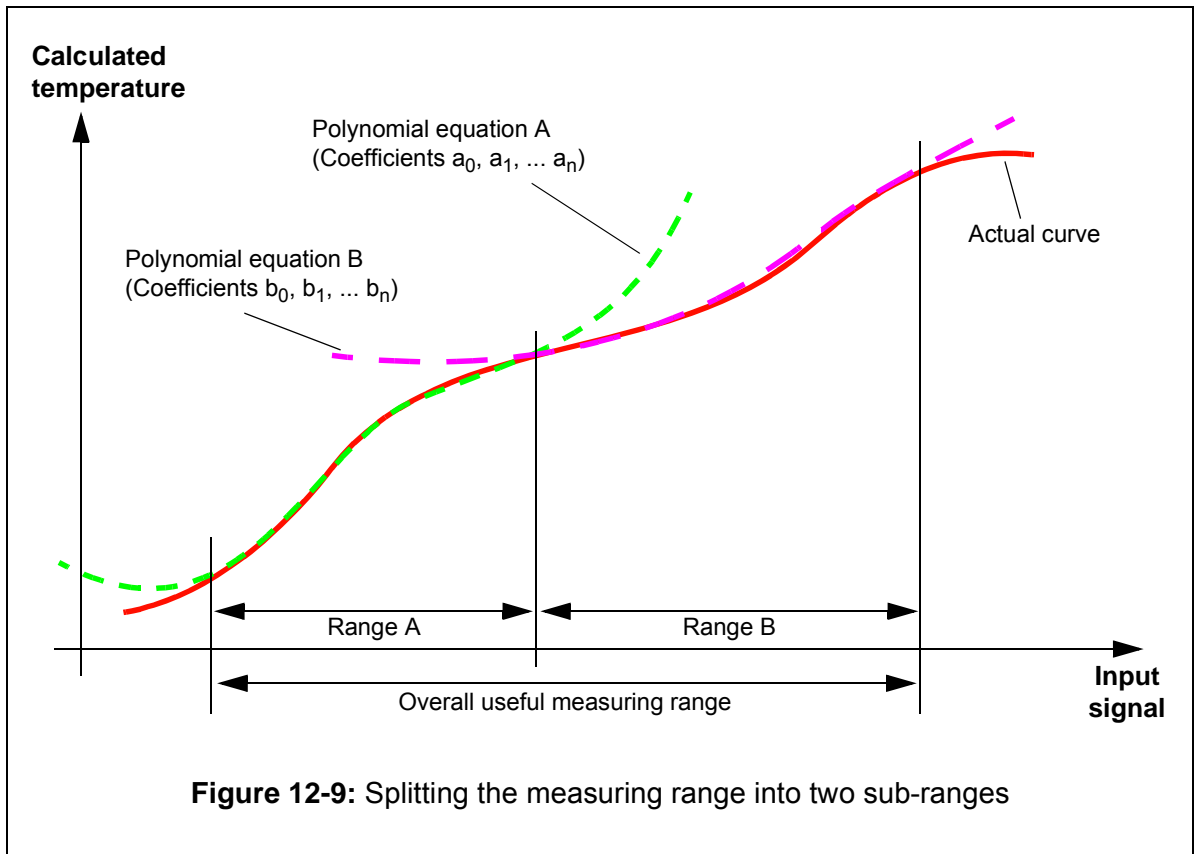

### 12.3.2.2 Using the tab

A simple example is presented here to illustrate how the Non-linear Compensation tab should be used.

Assume that a current-based sensor is connected to the channel. The Input Configuration tab is set up as shown in Figure 12-10. Click the **Non-linear** radio button so that the Non-linear Compensation tab becomes editable. A window resembling that shown in Figure 12-12 appears.

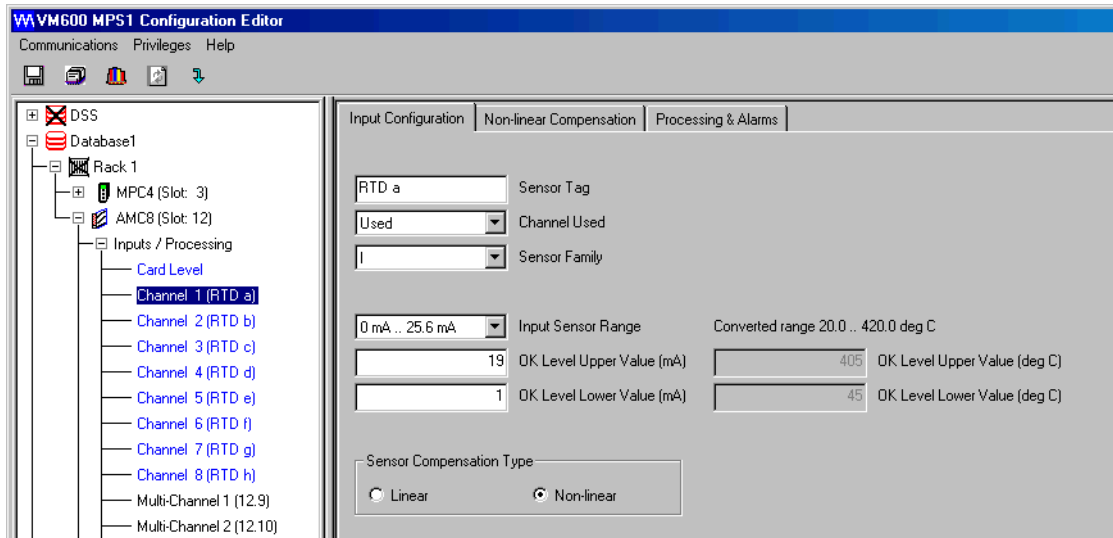

Figure 12-10: Example of setup for a current-based sensor

On the Non-linear Compensation tab, set the **Polynome Input Unit** to mA (as a current-based sensor is connected) and **Polynome Output Unit** to deg C (the desired temperature unit being °C).

In this example, it is known that the sensor has the following behaviour:

- The sensor outputs 0 mA at a temperature of 20°C
- Between 0 and 10 mA the sensitivity of the sensor is 25°C/mA
- Between 10 and 20 mA the sensitivity of the sensor is 15°C/mA.

The measuring range can be split into two parts: Range A for an output of 0 to 10 mA and Range B for an output of 10 to 20 mA. This is illustrated in Figure 12-11.

In Range A the offset is 20°C and the sensitivity is 25°C/mA.

In Range B the offset is 120°C and the sensitivity is 15°C/mA.

The two individual curves can be joined to form a composite curve (Figure 12-11) that does not have any discontinuity at the point where Range A meets Range B.

In the polynomial equation described in 12.3.2.1 Polynomial coefficients, the coefficients  $p_0$  and  $p_1$  in fact have the following significance:

- $p_0$  is the offset
- $p_1$  is the sensitivity (determining the slope of the curve).

The coefficients for the two ranges can therefore be entered into the table on the Non-linear Compensation tab as seen in Table 12-1 below.

**Table 12-1:** Polynomial coefficients needed for the example

Range A			Range B		
Coeff. name	Value	Displayed in software as	Coeff. name	Value	Displayed in software as
$a_0$	20	2.00000000E+01	$b_0$	120	1.20000000E+02
$a_1$	25	2.50000000E+01	$b_1$	15	1.50000000E+01

Enter the Start and Stop values (mA) for Range A and Range B as shown in Figure 12-12.

The conversion ranges can be read at the bottom of the window (Range A = 20 to 270 °C and Range B = 270 to 420 °C).

The overall measuring range (20 to 420 °C) can be seen on the Input Configuration tab in the text that reads "Converted range..." (see Figure 12-10).

The OK levels can now be defined on the Input Configuration tab using the **OK Level Upper Value** and **OK Level Lower Value** fields (see Figure 12-10).

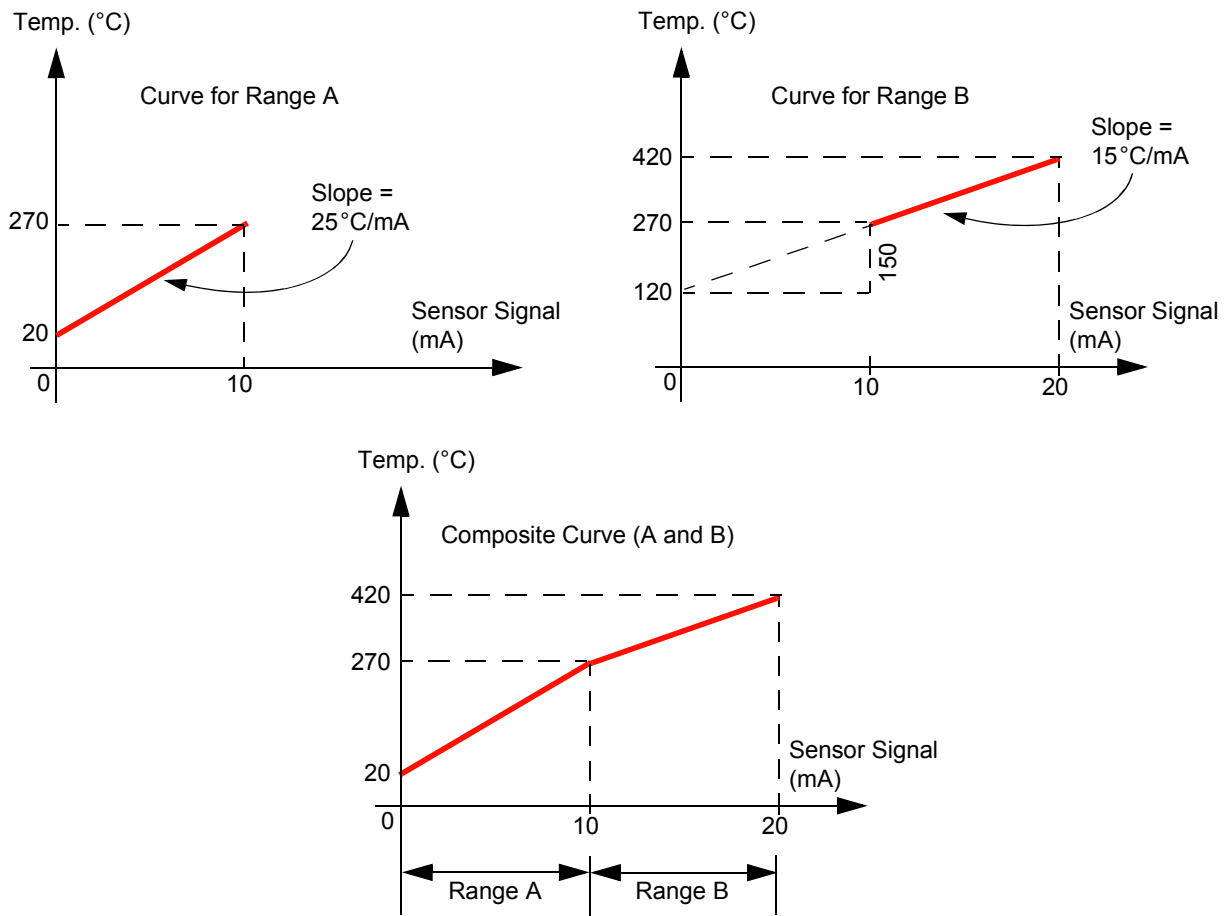

Figure 12-11: Example of forming a composite curve from two individual curves

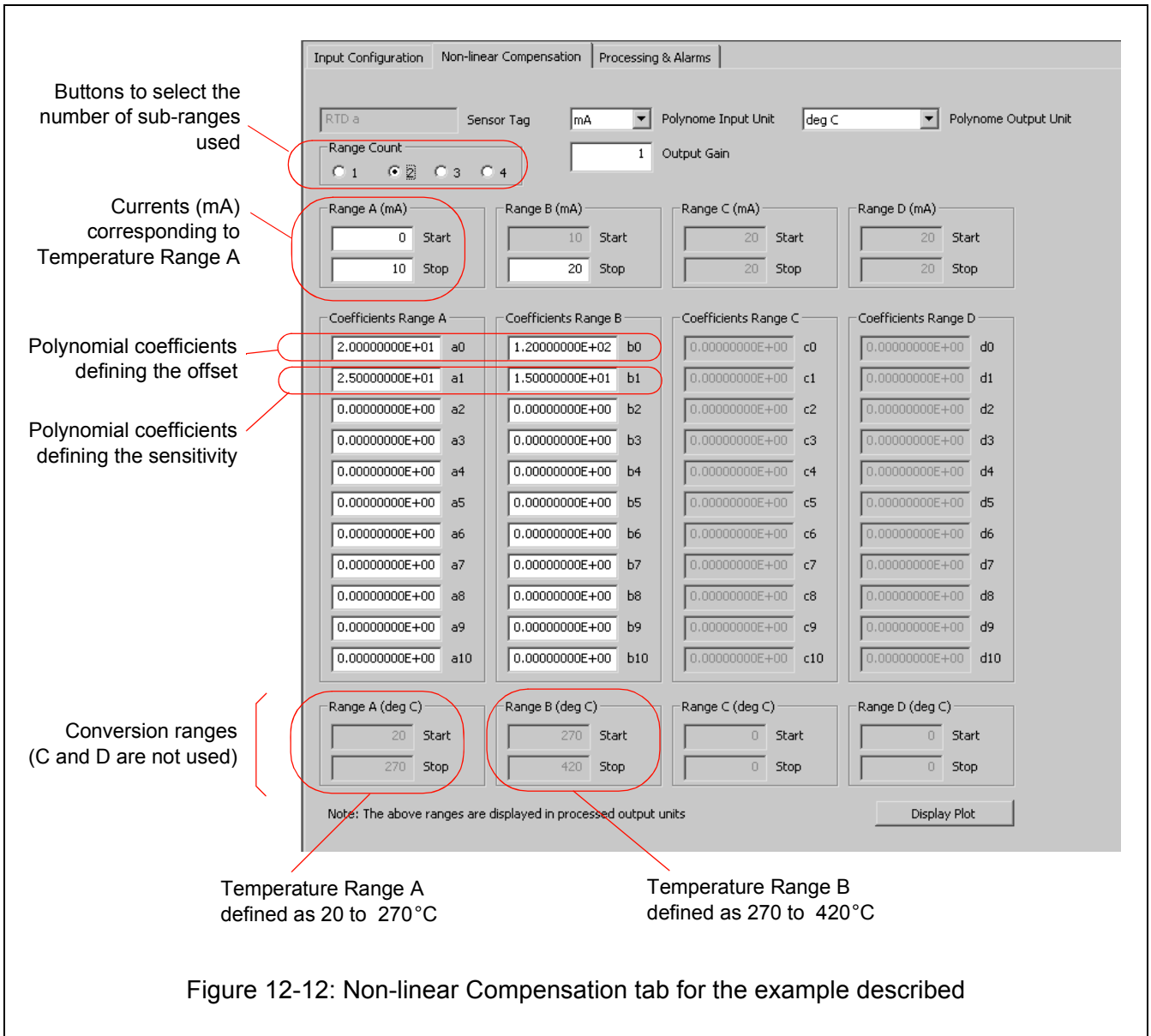

Figure 12-12: Non-linear Compensation tab for the example described

### 12.3.3 The Processing & Alarms tab

#### 12.3.3.1 Context

This tab (Figure 12-13) allows a time-domain processing function and alarm parameters to be configured for the selected channel.

Alarms detected by the software can be used to switch relays. To map an alarm to a specific relay, select the **Output Mapping \ Discrete outputs** branch of the configuration tree structure.

**NOTE:** See 14 Output mapping (AMC8) for further information.

If logical combinations of alarms are required, select the **Alarm Logical Combination** branch of the configuration tree structure once alarms parameters have been defined for all the individual channels of interest.

**NOTE:** See 13 Defining logical combinations of alarms (AMC8) for further information.

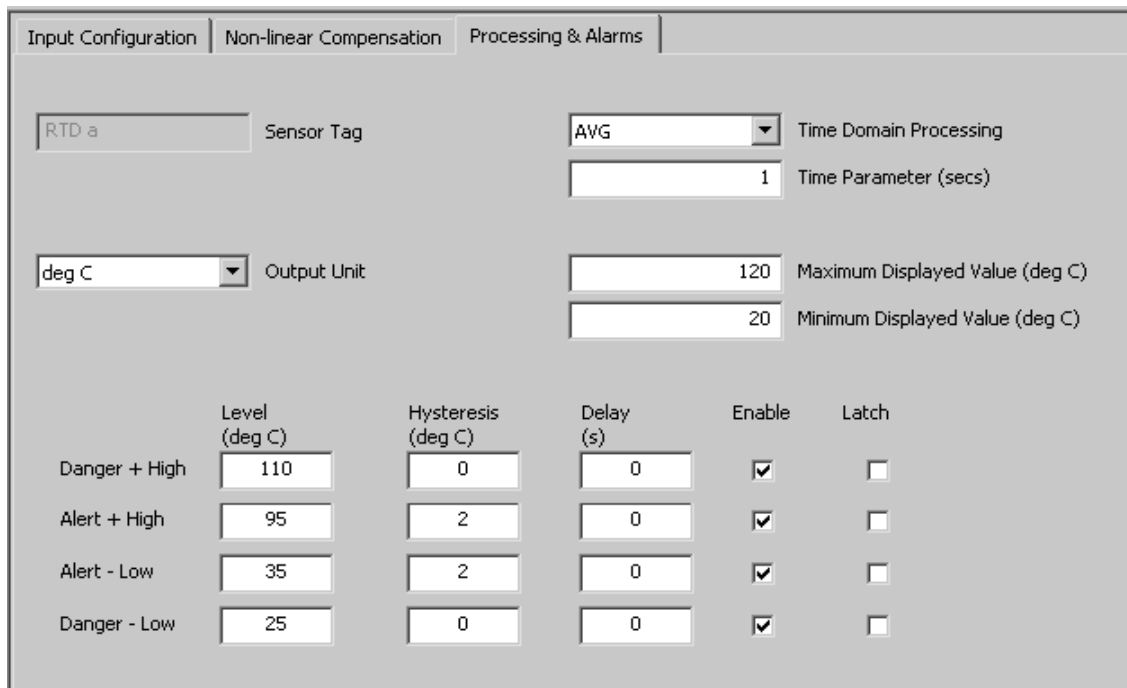

Figure 12-13: Processing & Alarms tab

### 12.3.3.2 Explanation of fields

#### Time Domain Processing

The following options can be chosen:

- None : No additional processing is performed
- MIN : Calculates the minimum value measured during the time period entered in the **Time Parameter** field
- MAX : Calculates the maximum value measured during the time period entered in the **Time Parameter** field
- AVG : Calculates the average of the values measured during the time period entered in the **Time Parameter** field.

#### Time Parameter

This field can be set to a value between 0.1 and 10.0 s (seconds). The value is used by the Time Domain Processing function (see above).

#### Output Unit

The temperature unit can be set to:

- deg C degrees Celsius (°C)
- deg F degrees Fahrenheit (°F)
- K Kelvin.

The unit chosen here does not have to be the same as that used on the Input Configuration and Non-linear Compensation tabs. If, for example, deg C was used on these two tabs and deg F is chosen here, the relevant fields on the Processing & Alarms tab are automatically converted to display in deg F.

### Maximum (Minimum) Displayed Value

These two settings determine the scale of the display on the front panel of the CPUM card (see Figure 12-14).

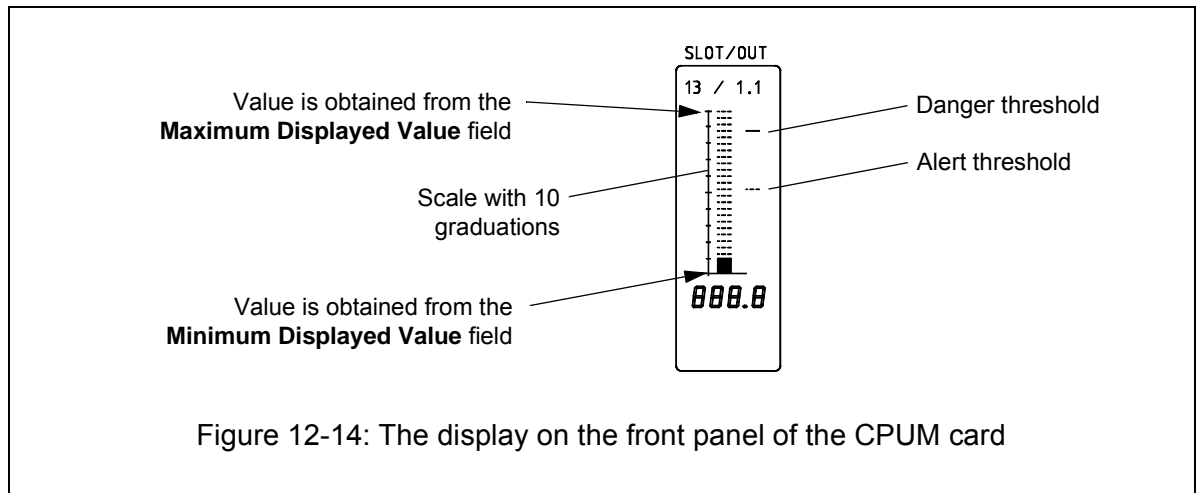

These values are not actually written on the CPUM card's display. It is a good idea to choose the two values so that, when the difference between them is divided by 10, the graduations on the scale correspond to a temperature interval that is a round number (for example, choosing a max. = 120°C and a min. = 20°C gives graduations at 30°C, 40°C and so on).

An error is signalled if you try to enter a value that is outside the range shown in the text on the Input Configuration tab that reads "Converted range..." (see Figure 12-10).

### Level

The values are expressed in the unit defined in the **Output Unit** field. They must be entered in decreasing order from:

- Danger+ High to
- Alert+ High to
- Alert- Low to
- Danger- Low.

### Hysteresis

The values are expressed in the unit defined in the **Output Unit** field.

The hysteresis value must always be positive. It is added to the A- and D- levels and subtracted from the A+ and D+ levels internally, to give hysteresis capability to the system. It is advised to set a hysteresis value of about 2 to 5% of the desired full scale for the output, but the optimum value actually depends on the noise on the output.

### Delay

The signal level must be over (or under, in the case of low-level alarms) the alarm level (including the hysteresis value) for longer than the alarm delay time before an alarm is generated.

**NOTE:** The range of alarm delay values supported by the measurement channels of an AMC8 card is 0 to 60 seconds with a resolution of 0.1 second (100 milliseconds). Correct operation cannot be guaranteed if a value outside the supported range of alarm delay values is configured.

**Enabled**

Selecting this check box means the alarm output is enabled, otherwise it is disabled.

**Latch**

Selecting this check box means the alarm output is latched, otherwise it is unlatched.

## 12.4 Configuring “multi-channels”

A window resembling that shown in Figure 12-15 appears when one of the four “multi-channels” (Multi-Channel 1 to Multi-Channel 4) is selected in the configuration tree structure. The window has two tabs:

- Processing
- Alarms.

### 12.4.1 The Processing tab

In order to use this tab, two or more single channels on the same AMC8 card must already have been configured. The **Channel Used** field on the Input Configuration tab (Figure 12-4) of each single channel must be set to Used.

Select one of the following functions from the **Processing Function** combo box (Figure 12-15):

<b>MIN</b>	Outputs the lowest value measured by the selected channels.
<b>MAX</b>	Outputs the highest value measured by the selected channels.
<b>AVG</b>	Calculates the average of the values measured by the selected channels.
<b>DIFF</b>	Calculates the difference between the values measured by two selected channels.

The chosen function acts on the channels selected under **Select Channels For Averaging**.

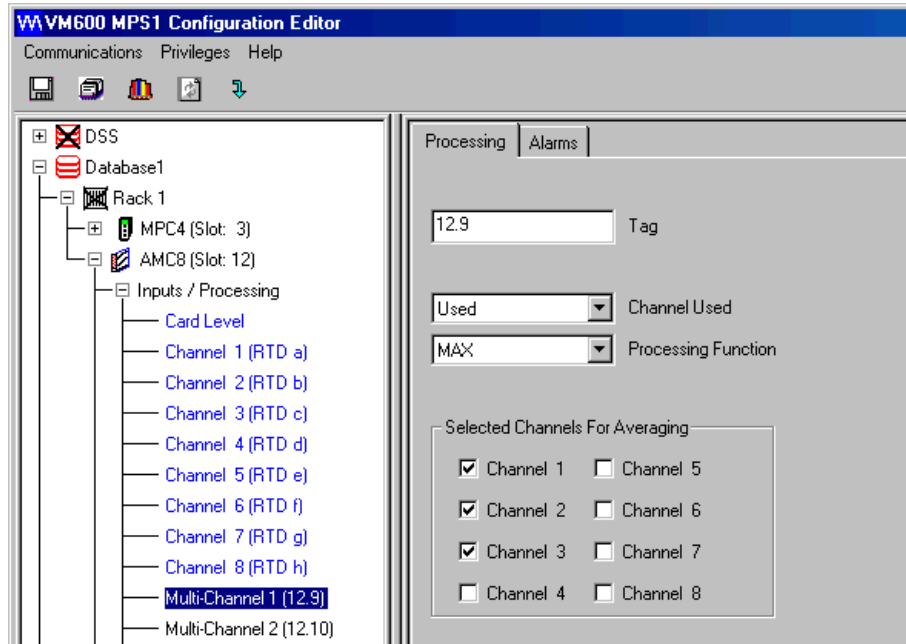

Figure 12-15: Processing tab for configuring multi-channels

If DIFF is chosen in the **Processing Function** field, the window resembles that shown in Figure 12-16. Choose the two channels under **Difference Channel Selection**.

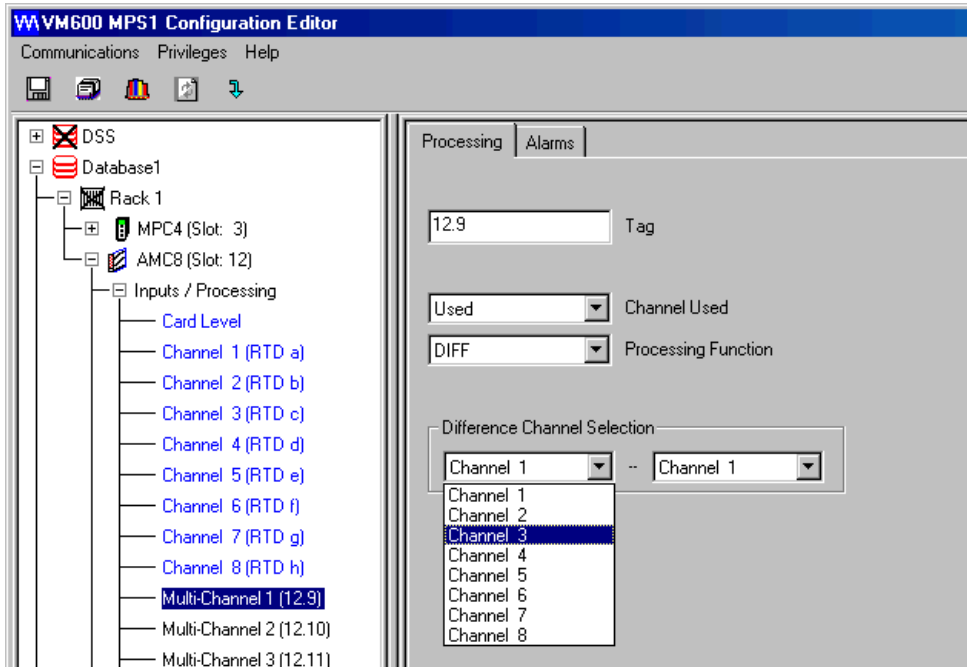

Figure 12-16: Using the DIFF processing function

### 12.4.2 The Alarms tab

This tab (Figure 12-17) allows a time-domain processing function and alarm parameters to be configured for the selected multi-channel. It is very similar in layout to the Processing and Alarms tab for single channels (Figure 12-13). The fields have the same functionality on both tabs.

**NOTE:** See 12.3.3.2 Explanation of fields for further information on the fields.

	Level (deg C)	Hysteresis (deg C)	Delay (s)	Enable	Latch
Danger + High	180	0	0	<input checked="" type="checkbox"/>	<input type="checkbox"/>
Alert + High	150	5	15	<input checked="" type="checkbox"/>	<input type="checkbox"/>
Alert - Low	0	0	0	<input type="checkbox"/>	<input type="checkbox"/>
Danger - Low	0	0	0	<input type="checkbox"/>	<input type="checkbox"/>

Figure 12-17: Alarms tab (for multi-channels)

## 12.5 Copying card configurations

When configuring AMC8 cards, copy operations are supported that allow the Inputs and Processings already configured for an AMC8 card to be re-used elsewhere on the same AMC8 card.

Using the copy operations for AMC8 card configurations helps to make the management of VM600 MPS Software configurations easier. For example, one channel of an AMC8 card could be configured and then re-used as the basis for other similar channels on the same card.

Drag-and-drop operations are available for use with the Inputs of an AMC8 card (Channels 1 to 8 and Multi-Channels 1 to 4).

To use the drag-and-drop operations:

- Click on an AMC8 card's channel level node (Channel or Multi-Channel) in the configuration tree to select it, then click on the channel again and drag it to a different channel (Channel or Multi-Channel).

---

**NOTE:** The copy operations for AMC8 card configurations are limited to the same AMC8 card (not between different AMC8 cards) and work on a channel basis, that is, the configuration of a channel input can be copied to another channel input, and the configuration of a multi-channel input can be copied to another multi-channel input.

---

**THIS PAGE INTENTIONALLY LEFT BLANK**

# 13 DEFINING LOGICAL COMBINATIONS OF ALARMS (AMC8)

## 13.1 Introduction

This section describes the Alarm Logical Combination branch of the configuration tree structure, visible when an AMC8 card is selected (see Figure 13-1). This branch allows logical combinations of alarms to be defined. The VM600 MPS1 software allows 16 basic functions and 8 advanced functions to be configured.

**NOTE:** Refer to the *VM600 Machinery Protection System (MPS)* hardware manual for further information on logical combinations of alarms.

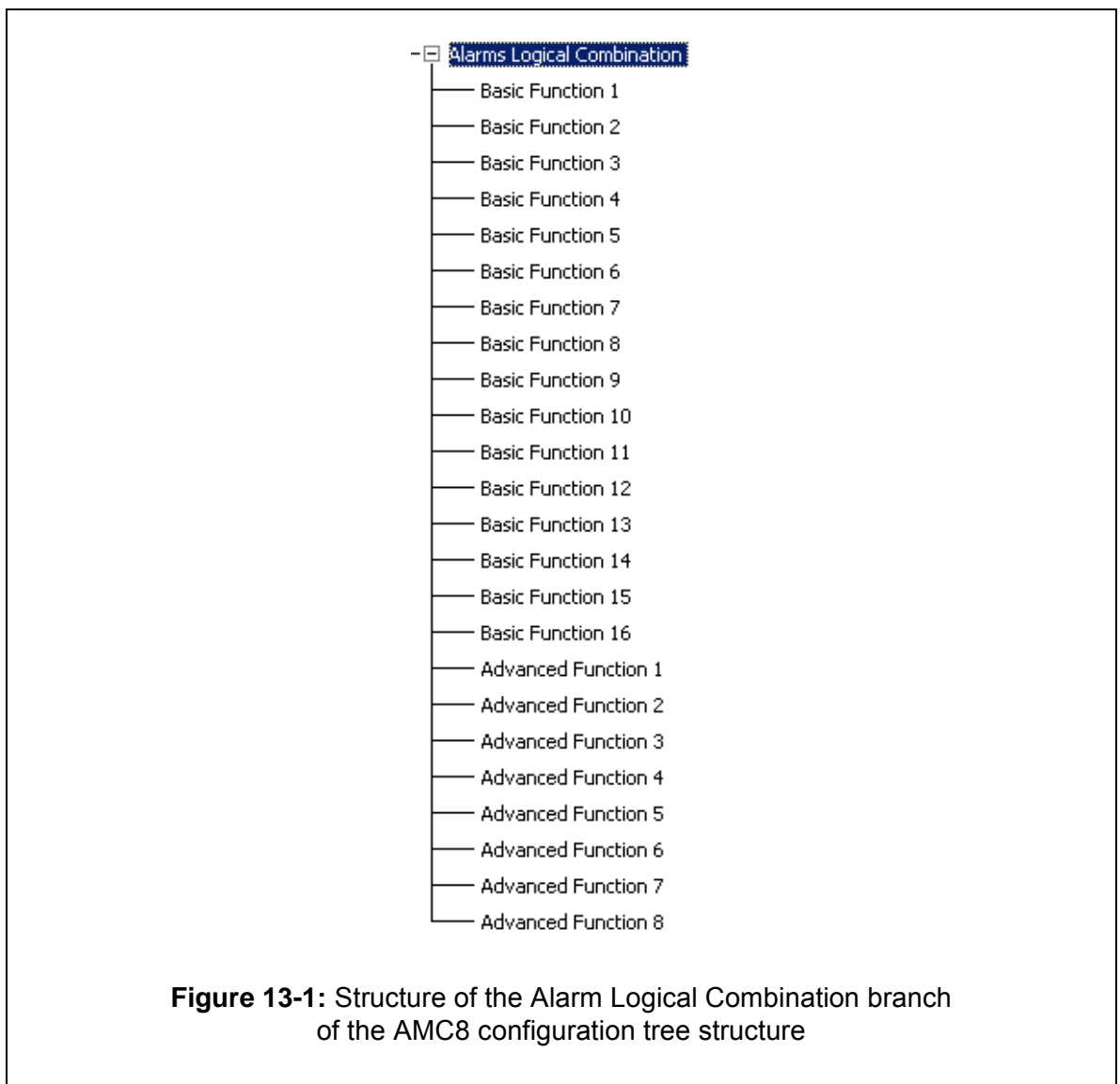

**Figure 13-1:** Structure of the Alarm Logical Combination branch of the AMC8 configuration tree structure

### 13.2 Defining a basic alarm function

A window resembling that shown in Figure 13-2 appears when one of the 16 Basic Functions is selected from the Alarm Logical Combination branch of the configuration tree structure. All operations can be done from this single window.

To define a basic function:

- 1- Determine which alarms have to be taken into consideration.  
 You can choose among the eight Single Channels, the four Multi-Channels and the various Status flags (Alarm Reset, Danger Bypass and so on).  
 One or more alarms can be selected from a given channel (for example, it is possible to select the Alert+ High and the Alert- Low alarms for Channel 1).
- 2- Use the mouse pointer to select each required alarm. Note that three states are possible:

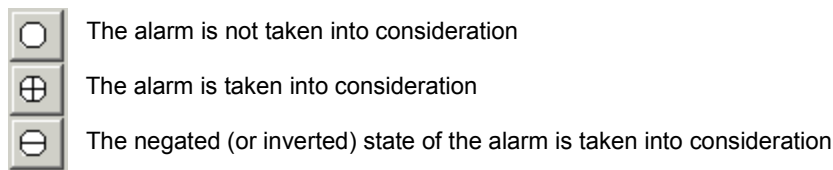

- 3- Select the logical function (AND, OR, Voting Logic) by clicking the appropriate radio button (**Logical AND**, **Logical OR** or **Voting Logic**).  
 If **Voting Logic** is selected, you must enter a number in the **Majority Parameter** field. In the example shown in Figure 13-2, Basic Function 1 shows an alarm condition if four or more of the eight constituent alarms are signalled.
- 4- The result of the logical function can be negated (inverted) if required by selecting the Inverted radio button. Otherwise, select the Not Inverted button.  
 Alternatively, keep clicking the required alarm to cycle between the three states: inactive, active and inverted.

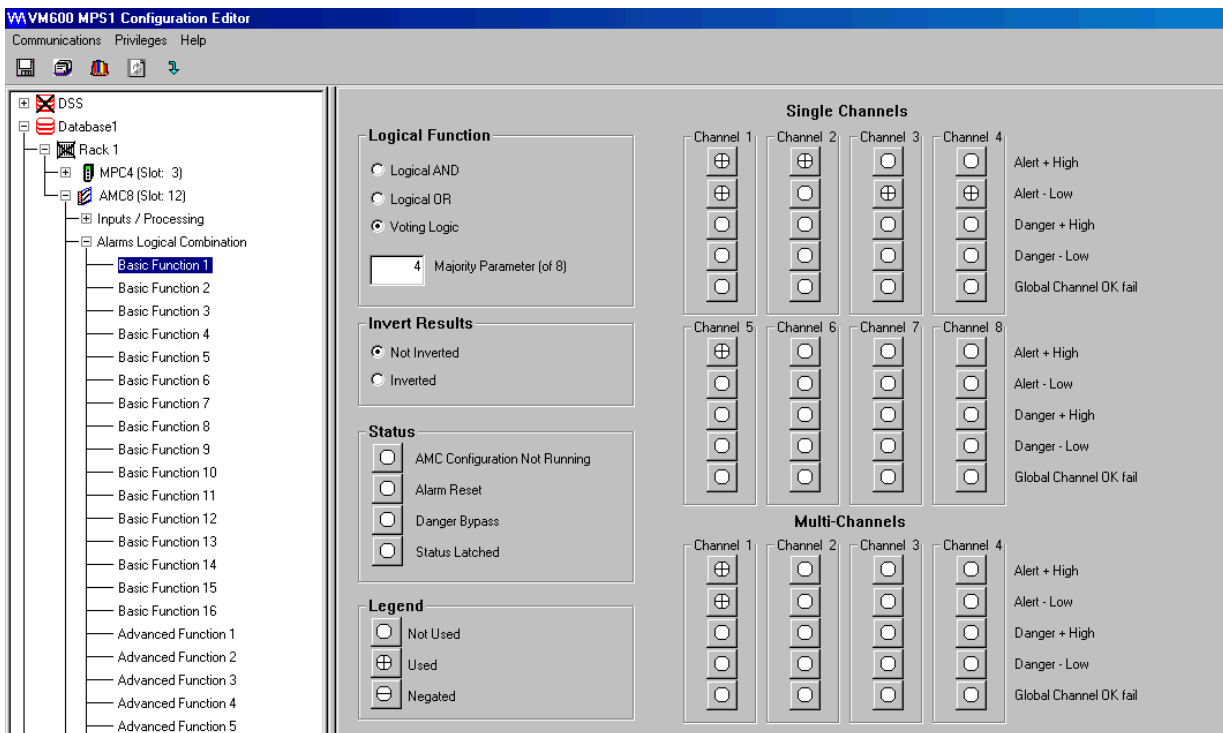

Figure 13-2: Window to select alarms for basic alarm combinations

### 13.3 Defining an advanced alarm function

A window resembling that shown in Figure 13-3 appears when one of the eight Advanced Functions is selected from the Alarm Logical Combination branch of the configuration tree structure.

To define an advanced alarm function:

- 1- Determine which basic alarm functions have to be taken into consideration.
- 2- Use the mouse pointer to select each required Basic Function. Note that three states are possible:

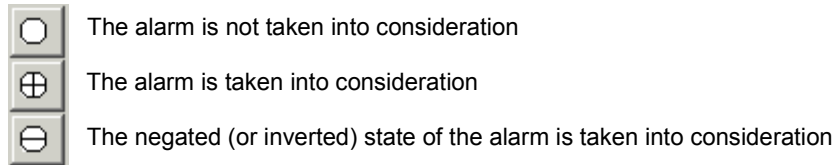

- 3- Select the logical function (AND, OR, Voting Logic) by clicking the appropriate radio button (**Logical AND**, **Logical OR** or **Voting Logic**).

If **Voting Logic** is selected, you must enter a number in the **Majority Parameter** field.

- 4- The result of the logical function can be negated (inverted) if required by selecting the **Inverted** radio button. Otherwise, select the **Not Inverted** button.

Alternatively, keep clicking the required alarm to cycle between the three states: inactive, active and inverted.

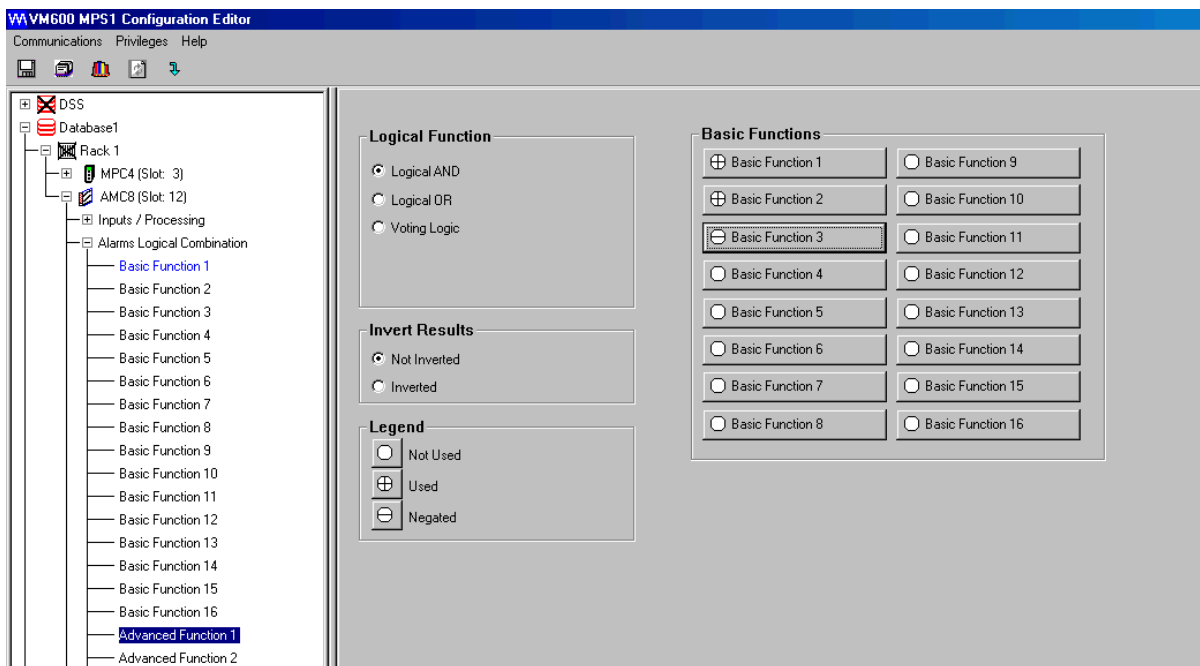

Figure 13-3: Window to configure advanced alarm functions

**THIS PAGE INTENTIONALLY LEFT BLANK**

## 14 OUTPUT MAPPING (AMC8)

### 14.1 Introduction

This section describes the Output Mapping branch of the configuration tree structure, visible when an AMC8 card is selected (see Figure 14-1).

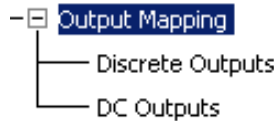

**Figure 14-1:** Structure of the Output Mapping branch of the AMC8 configuration tree structure

The **Output Mapping \ Discrete Outputs** branch allows individual and logically combined alarms to be attributed to specific relays on the IOC and RLC cards.

The **Output Mapping \ DC Outputs** branch allows the eight DC outputs (DC OUT 1 to DC OUT 8) to be configured.

### 14.2 Mapping alarms (discrete outputs)

The IOC8T card has four local relays. Alarm signals can be directly attributed to these relays under software control. No hardware adjustments need to be made, with the exception of the micro-switches on the IOC8T card that are used to configure the card's relays as normally energised (NE) or normally de-energised (NDE).

---

**NOTE:** Refer to the *VM600 Machinery Protection System (MPS)* hardware manual for further information on using these micro-switches.

---

If additional relays are needed, an RLC16 card containing 16 relays can be installed in the VM600 MPS. An alarm signal is attributed to a relay on the RLC16 in two stages:

- 1- The alarm signal is mapped to a relay using the VM600 MPS1 software. The user can choose whether the mapping takes place via the Open Collector Bus (OC Bus) or the Raw Bus.
- 2- If the OC Bus is used, a jumper must be set on the RLC16 card to enable the OC Bus line that is associated with that specific relay.  
or
- 3- If the Raw Bus is used, a jumper must be set on the IOC8T card to select one of the four Raw Bus line associated with that particular relay. Another jumper must be set on the RLC16 card to connect the Raw Bus line chosen to the specific relay.

---

**NOTE:** Refer to the *VM600 Machinery Protection System (MPS)* hardware manual for further information on using the OC Bus and the Raw Bus to switch relays on the RLC16.

---

Alarms are mapped to specific relays on the IOC8T card or RLC16 card (via OC Bus lines or Raw Bus lines) using the Discrete Outputs node in the Output Mapping branch of the configuration tree structure. When this node is selected, a relay mapping window appears (see Figure 14-2). This contains:

- 1- A **Relay Mapping** tree structure (left)
- 2- Combo boxes called **Source** and **Type** for selection of alarms
- 3- An **Apply** button.

To map an alarm to a relay:

- 1- Click a node (small box containing a "+" sign) in the tree structure to show more of the tree (Figure 14-3 shows the IOC Relays branch opened up).

Select the branches as follows:

<b>IOC Relays</b>	To select one of the 4 local relays on the IOC8T card.
<b>RLC / OC Bus</b>	To select one of the 16 relays on the RLC16 card using the OC Bus.
<b>RLC / Raw Bus</b>	To select one of the 16 relays on the RLC16 card using the Raw Bus.

Each line of a branch represents a relay. The numbers correspond to the relay numbers found on the rear panel of the respective card (IOC8T or RLC16).

- 2- Click the appropriate line to select a specific relay.
- 3- Choose an entry from the **Source** combo box. This allows the choice of any single channel, multi-channel, logically combined alarm (basic function or advanced function) or Common Status information.
- 4- Choose an entry from the **Type** combo box to precisely define the alarm.
- 5- Click the **Apply** button to attribute the alarm signal to the relay. The line now shows the alarm designation (for example, in Figure 14-3, Relay 2 on the IOC8T is attributed to the Channel 1 Alarm+ signal).

You cannot attribute the same alarm to two different relays. If this is attempted, an error message appears asking if you want to delete the first mapping. Click **Yes** or **No** as appropriate.



Figure 14-2: Relay Mapping tree structure (for AMC8 card)

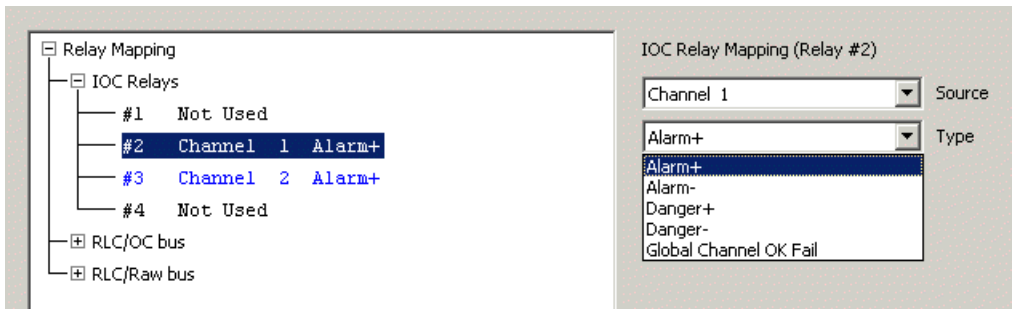

Figure 14-3: Example of attributing Relay 2 on the IOC8T card to the “Channel 1, Alarm+” alarm

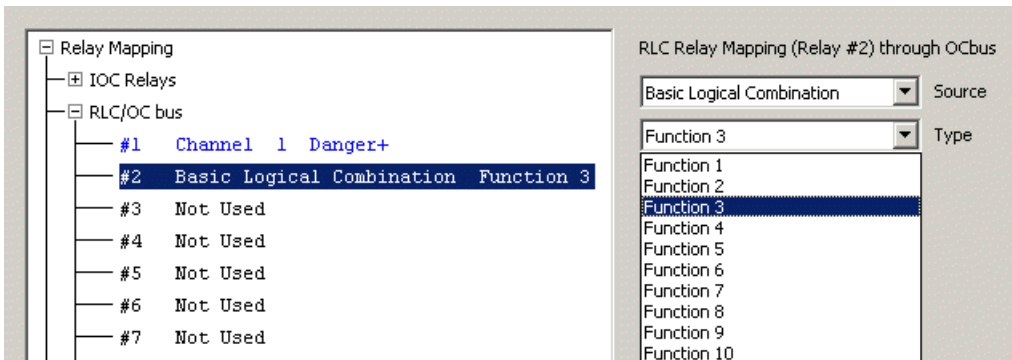

Figure 14-4: Example of attributing Relay 2 on the RLC16 card to Basic Function 3. The OC Bus is used to route the alarm.

## 14.3 Configuring DC outputs (analog outputs)

The IOC8T has eight analog outputs named DC OUT 1 to DC OUT 8. These are configured in the factory to provide a current-based output of 4 to 20 mA.

---

**NOTE:** On special request, these eight outputs can be configured to provide a voltage-based output (0 to 10 V).  
Contact your nearest Meggitt Sensing Systems representative for further information on this option.

---

Specific signals may be attributed to each analog output by selecting the **Output Mapping\DC Outputs** branch of the configuration tree structure. When this node is chosen, a DC Outputs configuration window appears (see Figure 14-5).

To configure a specific DC output:

- 1- Click the combo box in the left-most column (**IOC DC Output**) to show the list of signals that can be chosen.

---

**NOTE:** In the window, IOC DC Output 1 corresponds to the terminal called DC OUT 1 on the panel of the IOC8T card.  
Similarly, IOC DC Output 2 corresponds to DC OUT 2, and so on.

---

In the example shown in Figure 14-5, the choices are Channel 1, Channel 2, Channel 3, Multi-Channel 1 and Multi-Channel 4.

Note that these five channels are highlighted in blue in the Inputs \ Processing branch of the configuration tree structure, indicating that for each of them the **Channel Used** field on the Input Configuration tab is set to Used (see Figure 12-4).

- 2- Choose a signal from the list.
- 3- Enter a value in the **Minimum Level** column.  
This value corresponds to an output of 4 mA (or 0 V if a voltage-based output is configured)
- 4- Enter a value in the **Maximum Level** column.  
This value corresponds to an output of 20 mA (or 10 V if a voltage-based output is configured)

### To delete an existing routing

If you want to delete an existing analog output definition:

- 1- Select the signal again from the combo box in the left-most column (**IOC DC Output**).
- 2- Select the **Not Used** option.

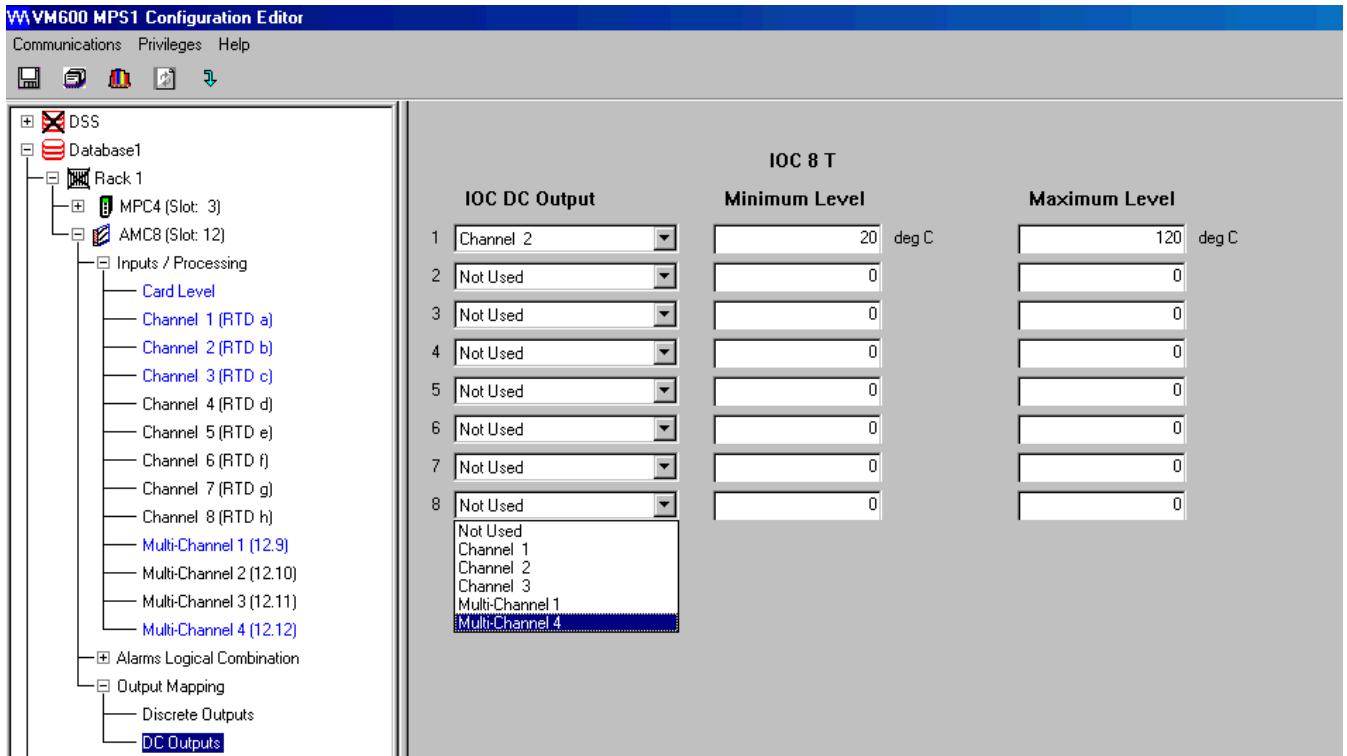

Figure 14-5: DC Outputs configuration window (for AMC8 card)

**THIS PAGE INTENTIONALLY LEFT BLANK**

## 15 COMMUNICATIONS MENU (AMC8)

### 15.1 Introduction

This section describes the commands available in the **Communications** drop-down menu at rack level and at AMC8 card level (see 6 Main window menus and commands). The structure of the menu is shown in Figure 15-1.

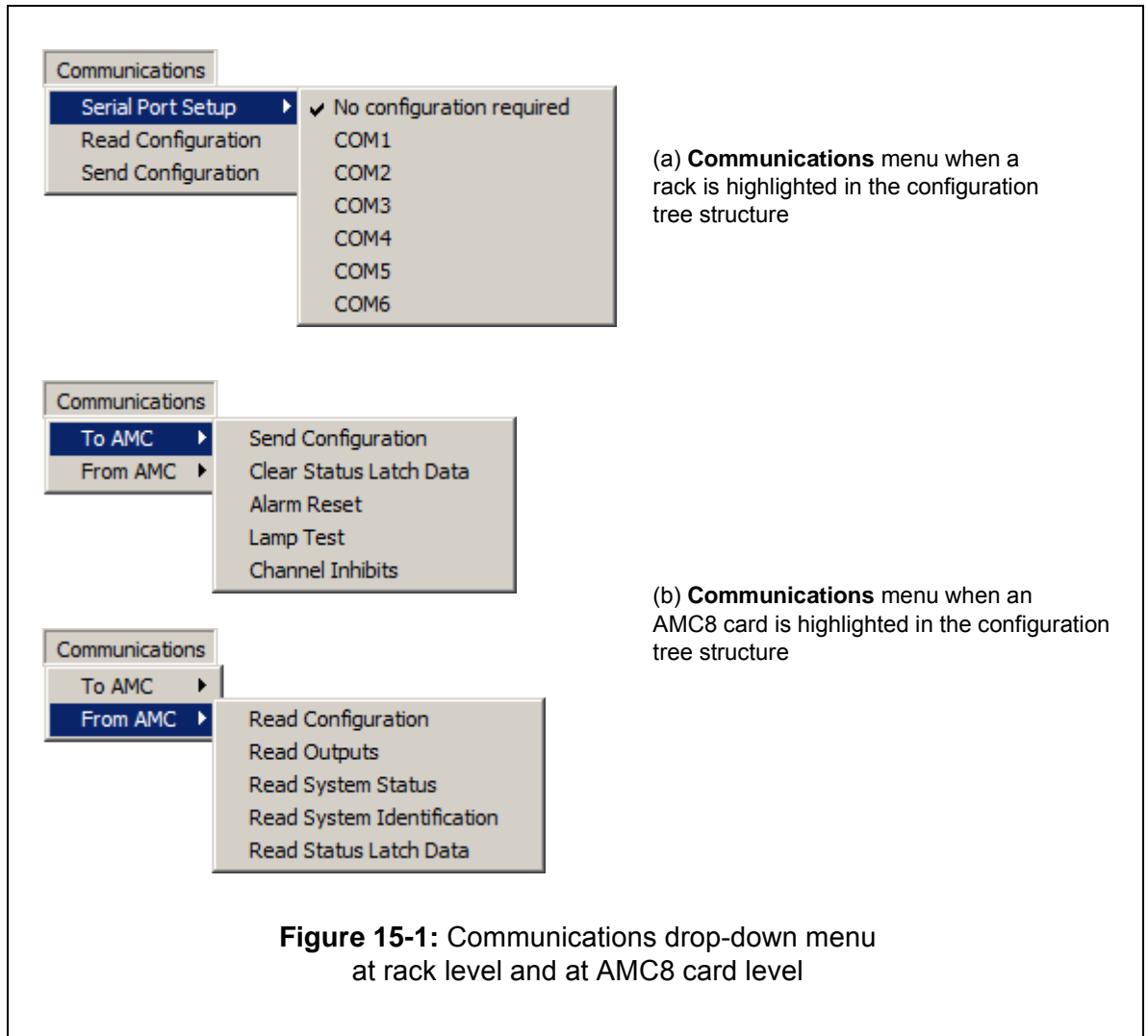

Note that at rack level (that is, when a rack is highlighted in the configuration tree structure), selecting **Read Configuration** uploads the configuration of all cards from the rack and selecting **Send Configuration** downloads the configuration of all cards to the rack.

See also 6.3.3 Sending a configuration to a VM600 rack or card.

## 15.2 Communication with a stand-alone rack (no CPUM present)

The procedure for a rack with AMC8 cards is the same as for a rack with MPC4 cards.

---

**NOTE:** See 11.2 Communication with a stand-alone rack (no CPUM present) for details. Simply read “AMC8” for “MPC4” in the description.

---

## 15.3 Communication with a networked rack (CPUM present)

The procedure for a rack with AMC8 cards is the same as for a rack with MPC4 cards.

---

**NOTE:** See 11.3 Communication with a networked rack (CPUM present) for details. Simply read “AMC8” for “MPC4” in the description.

---

## 15.4 Downloading the configuration (Send Configuration)

See also 6.3.3 Sending a configuration to a VM600 rack or card.

### Networked rack

To download an entire rack configuration to a networked rack:

- 1- Activate the communications link (Ethernet or PPP) to the rack as described in 11.3 Communication with a networked rack (CPUM present).
- 2- From the configuration tree structure, select the rack you want to download the configuration to.  
This should be the same rack as in step 1 above.
- 3- Select **Send Configuration** from the **Communications** drop-down menu.

To download a single card's configuration to a networked rack:

- 1- In the configuration tree structure, select the card you want to download.
- 2- Select **Communications**, **To AMC**, and **Send Configuration**.

### Stand-alone rack

For a stand-alone rack, the configuration of each card can be downloaded one card at a time as follows:

- 1- Activate the communications link (RS-232 serial link) to the card in question as described in 11.2.1 Setup procedure.
- 2- From the configuration tree structure, select the card you want to download the configuration to.  
This should be the same card as in step 1 above.
- 3- Select **To AMC** from the **Communications** drop-down menu and choose the **Send Configuration** command.

## 15.5 Reading the configuration (Read Configuration)

When a new card is installed in a slot its configuration can be “uploaded” to the VM600 MPS1 software for analysis.

If required, the configuration can then be saved under a particular name by selecting **Export AMC Configuration** from the **File** drop-down menu.

### Networked rack

To upload the configuration of an individual card, or the entire rack, to the personal computer:

- 1- Activate the communications link (Ethernet or PPP) to the rack as described in 11.3 Communication with a networked rack (CPUM present).
- 2- From the configuration tree structure, select the card you want to upload the configuration from.  
You can also upload the configuration of the entire rack by selecting the rack in the configuration tree structure.
- 3- Select **Read Configuration** from the **Communications** drop-down menu.

### Stand-alone rack

For a stand-alone rack, the configuration of each card can be uploaded one card at a time as follows:

- 1- Activate the communications link (RS-232 serial link) to the card in question as described in 11.2.1 Setup procedure.
- 2- From the configuration tree structure, select the card you want to upload the configuration from.  
This should be the same card as in step 1 above.
- 3- Select **From AMC** from the **Communications** drop-down menu and choose the **Read Configuration** command.

## 15.6 Testing the communications link (Read System Identification)

To test the communication link, select **From AMC** from the **Communications** menu and choose the **Read System Identification** command. The System Identification window appears, as shown in Figure 15-2.

In the case of a problem, this window contains information that can be communicated to Meggitt Sensing Systems customer support.

```
Serial Number : ABCDEF
AMC Hardware Part Number : 200-550-000-XXX
AMC Software Part Number : 209-550-200-XXX

IOC Hardware Part Number : 200-580-000-XXX
IOC PCB Assembly Part Number : 200-580-100-XXX

IOC Identification : IOC 8T
Slot Number : 12
Slot Assignment : 12
```

**Figure 15-2:** System Identification window (for AMC8 / IOC8T card pair)

## 15.7 The status latch (clearing and reading)

When an alarm or flag with the ability to be latched occurs, the event is noted on a “latched event list”. This can be examined by selecting **From AMC** from the **Communications** menu and then choosing the **Read Status Latch Data** command. A window resembling that shown in Figure 15-3 appears.

This feature is useful for checking if an event has occurred over a certain period of time (that is, since the last Clear Status Latch Data operation), when the operator cannot permanently check the output data.

The latched data can be cleared at any moment by selecting **To AMC** from the **Communications** menu and then choosing the **Clear Status Latch Data** command.

### Data Concerning Single Channels and Multi-Channels

Information on each channel is provided as a 32-bit value that is hexadecimal coded and represented by eight bytes (the prefix “0x” indicates the data is in hexadecimal). If no alarm/failure is present, the code 0x00000000 is returned. If an alarm/failure occurs, the code is followed by text describing the problem (for example, Alarm+, Global Channel OK Fail).

The 32-bits are defined as shown in Table 15-1.

### Data Concerning Common Status

Common Status information is provided as a 32-bit value that is hexadecimal coded and represented by eight bytes. The code is followed by text describing the status (for example, Status Latched).

The 32-bits are defined as shown in Table 15-2.

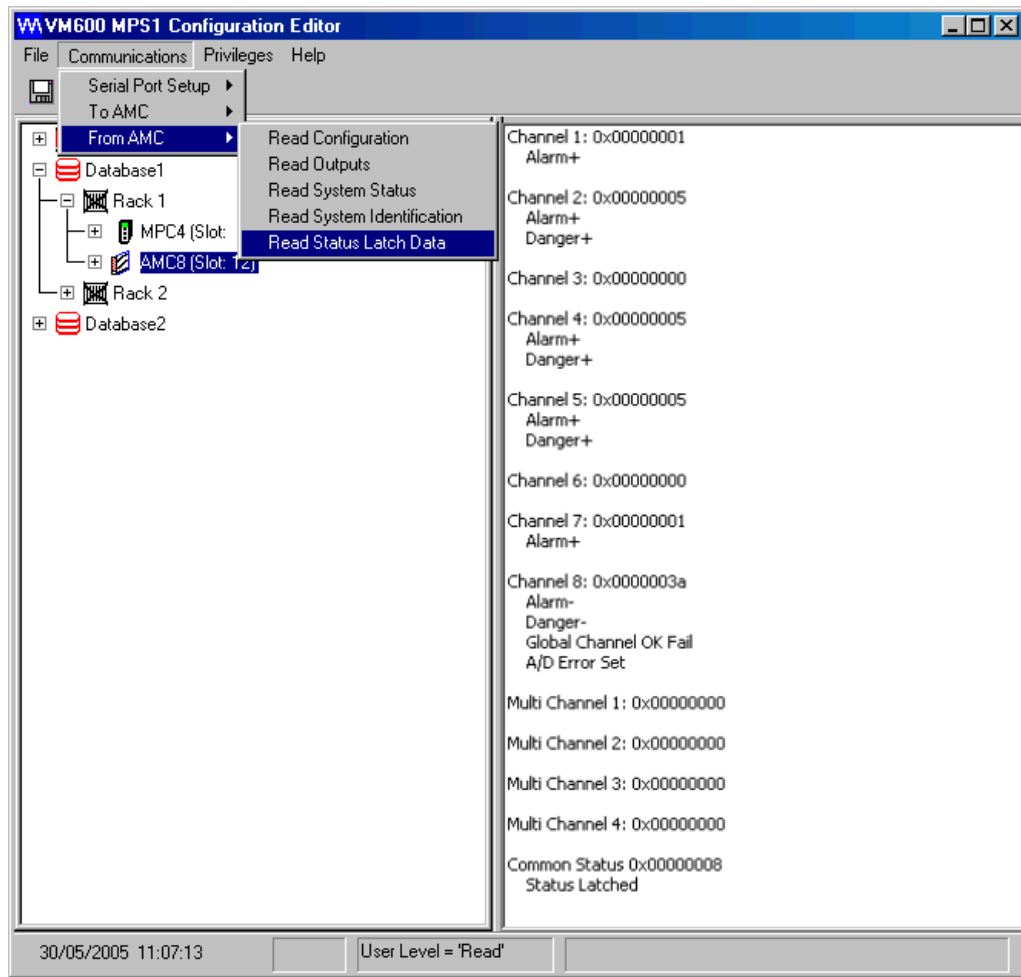

Figure 15-3: Read Status Latch Data window

**Table 15-1:** Definition of bits for latch data concerning single channels and multi-channels

Bit Number	Hex. Byte	Definition
Bit 0	0 (LSB)	Alarm+ (boolean)
Bit 1		Alarm- (boolean)
Bit 2		Danger+ (boolean)
Bit 3		Danger- (boolean)
Bit 4	1	Global Channel OK fail (boolean)
Bit 5		A/D error set (boolean)
Bit 6		A/D standby set (boolean)
Bit 7		A/D PLL lock error (boolean)
Bit 8	2	A/D transmission error (boolean)
Bit 9		A/D dynamic configuration error (boolean)
Bit 10		BIT result fail (boolean)
Bit 11		No sample received (boolean)
Bit 12	3	OK Level fail (boolean)
Bit 13		Outside linearisation range error (boolean)
Bit 14		Cold junction temperature error (boolean)
Bit 15		Not used
Bits 16 to 19	4	Not used
Bits 20 to 23	5	Not used
Bits 24 to 27	6	Not used
Bits 28 to 31	7 (MSB)	Not used
Status of bits:		
<b>Setting</b>		<b>Definition</b>
Bit set to 0 (false)		normal / no Alarm / no Danger / flag not set / no error
Bit set to 1 (true)		not normal / Alarm / Danger / flag set / error

**Table 15-2:** Definition of bits for latch data concerning common status

Bit Number	Hex. Byte	Definition
Bit 0	0 (LSB)	ACNR: AMC configuration not running (boolean)
Bit 1		AR: Alarm Reset (boolean)
Bit 2		DB: Danger Bypass (boolean)
Bit 3		SL: Status Latched (boolean)
Bits 4 to 7	1	Not used
Bits 8 to 11	2	Not used
Bits 12 to 15	3)	Not used
Bits 16 to 19	4	Not used
Bits 20 to 23	5	Not used
Bits 24 to 27	6	Not used
Bits 28 to 31	7 (MSB)	Not used
Status of bits:		
<b>Setting</b>		<b>Definition</b>
Bit set to 0 (false)		Configuration running / no SL / no DB / no AR
Bit set to 1 (true)		Not normal / Alarm / Danger / flag set / error

## 15.8 The AMC outputs window (Read Outputs)

The AMC Outputs window (Figure 15-4) show detailed information concerning measured values, alarms, hardware and software status. The window is called up by selecting **From AMC** from the **Communications** menu and then choosing the **Read Outputs** command.

Measurements can be obtained in two ways:

- 1- A single acquisition can be made, providing a “snapshot” of the machine status at a given moment in time.  
To do this, click the **Get Outputs** button (Figure 15-5). The button to the right of this one should read “**Poll Outputs**” (indicating continuous acquisitions are presently disabled).
- 2- A continuous series of acquisitions can be made. The period between successive acquisitions is fixed at 1.0 second.  
To do this, click the **Poll Outputs** button (Figure 15-5). The text on the button changes to “**End Polling**” when this is done. Click the **End Polling** button to stop acquiring data.

To end the session, click the **Done** button.

### 15.8.1 Explanation of fields

The AMC Outputs window can be broken down into the following areas for the purposes of this explanation:

- 1- Fields concerning the eight single channels (see Figure 15-6)
- 2- Fields concerning the four multi-channels (see Figure 15-8)
- 3- Fields concerning the basic and advanced logical combinations of alarms (see Figure 15-9)
- 4- Fields concerning status information (see Figure 15-10)

The **AMC Running** indicator (see Figure 15-4) has the following behaviour:

- It flashes green/white alternately when the configuration is running.
- It is continually red when the configuration is not running.

When this occurs, it is often due to an incorrect configuration. It may also occur during the AMC8 card's warm-up period.

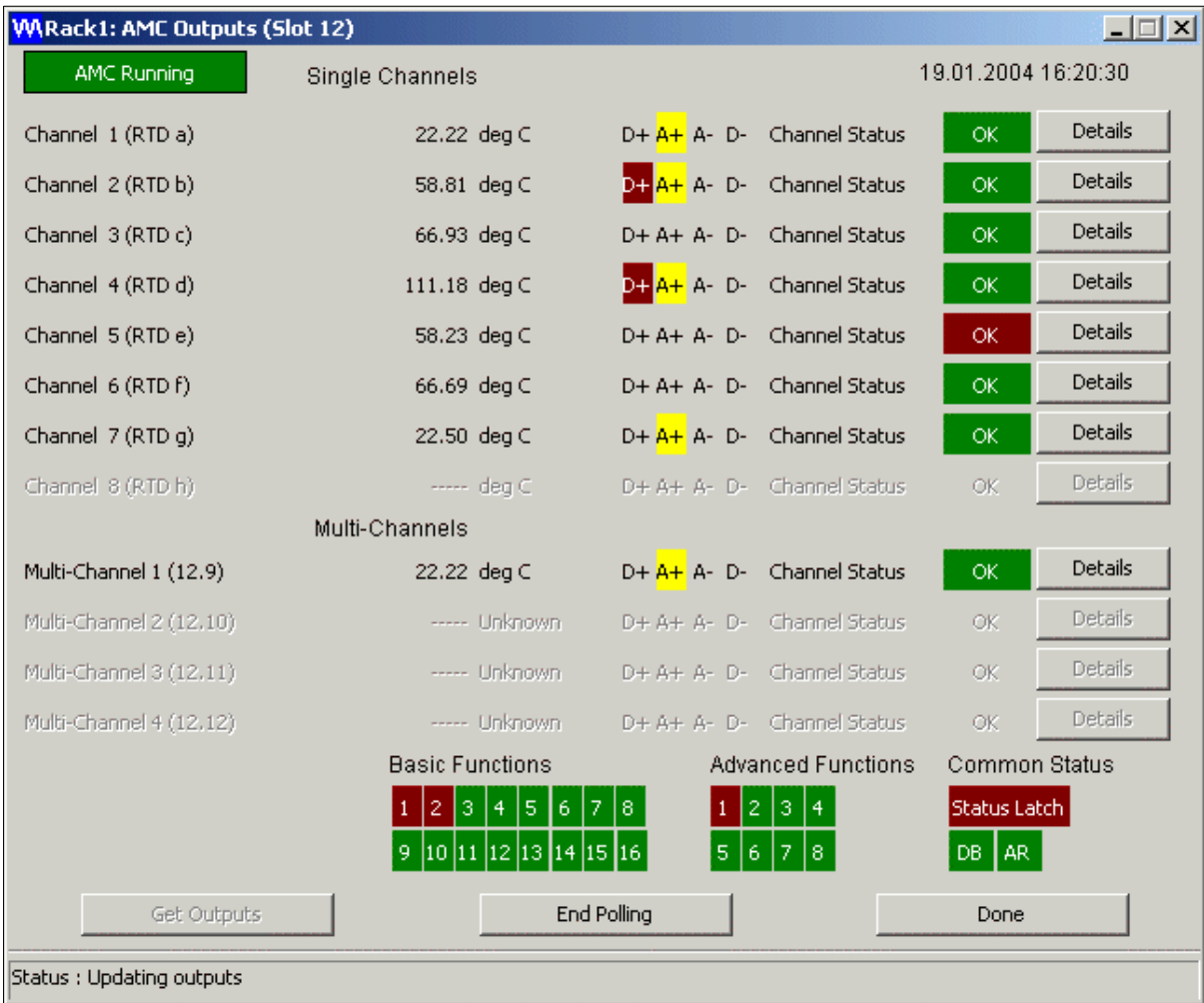

Figure 15-4: Typical AMC Outputs window



**Figure 15-5:** Get Outputs and Poll Outputs buttons

### 15.8.1.1 Fields concerning the eight single channels

The AMC Outputs window shows measured values and alarm status for the eight single channels (see Figure 15-6).

A line appears dimmed (greyed out) if the **Channel Used** field on the Input Configuration tab (see Figure 12-4) is set to Not Used (this is the case for Channel 8 in Figure 15-6).

The first column shows the channel number, followed in brackets by the sensor tag entered for the channel. This tag is defined in the **Tag** field of the Input Configuration tab.

The second column shows the measured value. This is expressed in the units selected in the **Output Unit** field of the Processing & Alarms tab (see Figure 12-13).

The Alert+ (A+) and Alert- (A-) alarm flags indicate when the measured value is in/out of Alert limits. The following colour coding applies:

- Grey, indicating the value is within Alert limits
- Yellow, indicating the value is out of Alert limits.

The Danger+ (D+) and Danger- (D-) alarm flags indicate when the measured value is in/out of Danger limits. The following colour coding applies:

- Grey, indicating the value is within Danger limits (NB: The value may nevertheless be out of Alert limits)
- Red, indicating the value is out of Danger limits.

The Channel Status OK indicator shows at a glance whether there is a processing error for the channel in question. The following colour coding applies:

- Green, indicating no channel failure
- Red, indicating channel failure.

More information on the channel status can be obtained by clicking the **Details** button. A window resembling that shown in Figure 15-7 appears when this is done. In the absence of a problem, every parameter is indicated as being “false”.

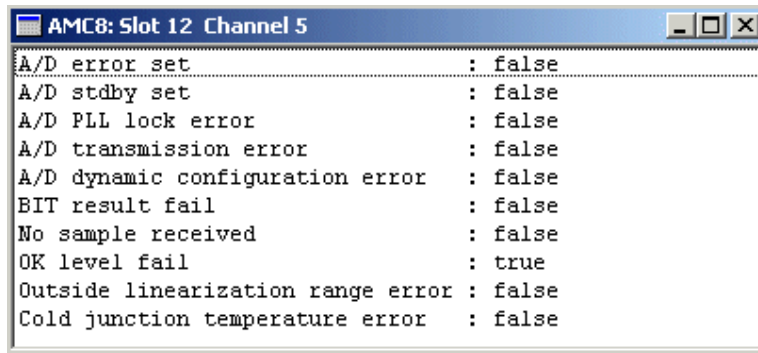
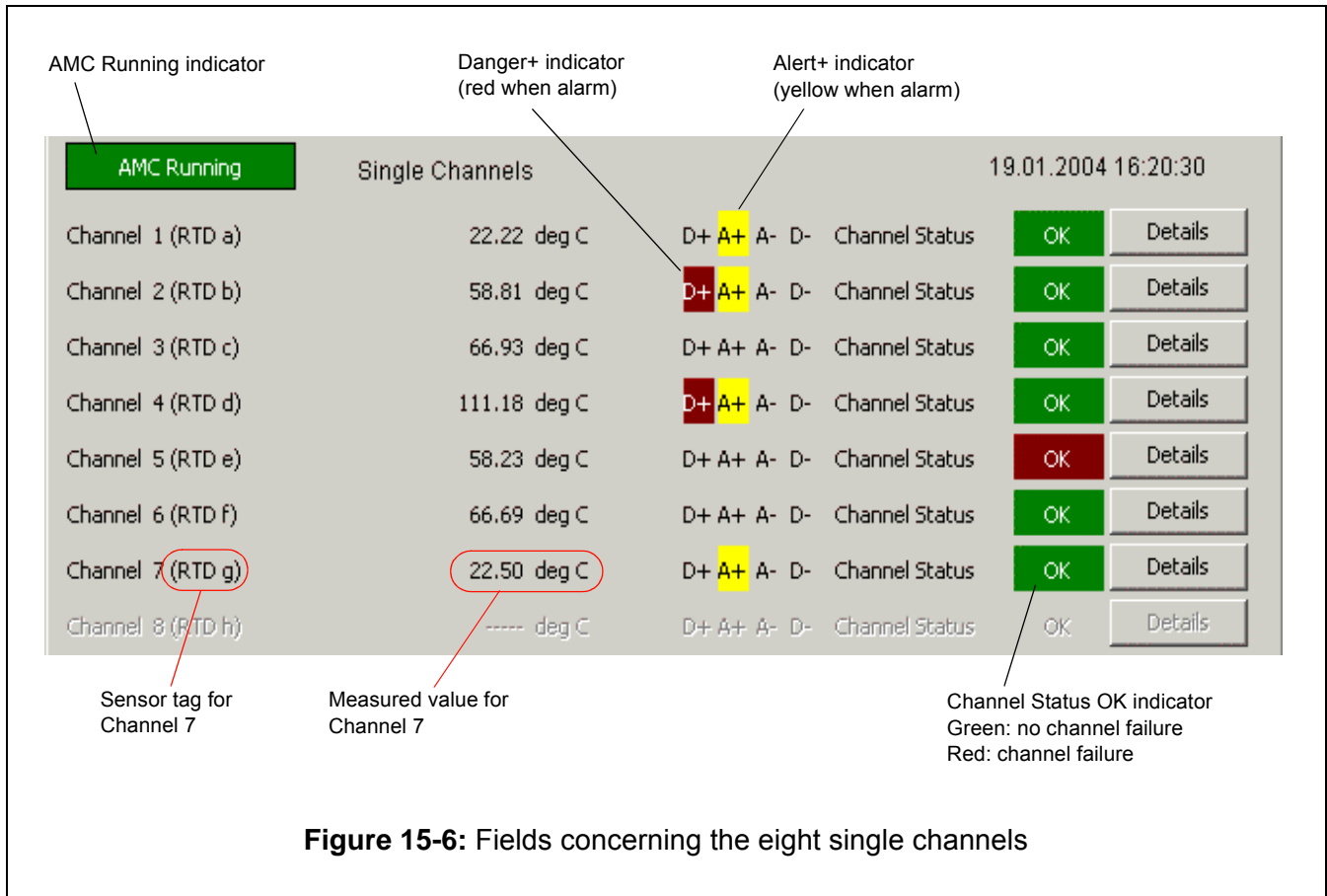

**Figure 15-7: Window showing channel status details**

**15.8.1.2 Fields concerning the four multi-channels**

The AMC Outputs window shows measured values and alarm status for the four multi-channels (see Figure 15-8). The type of information shown, the colour-coding of alarms and so on, is exactly as for the eight single channels. See 15.8.1.1 Fields concerning the eight single channels for further information.

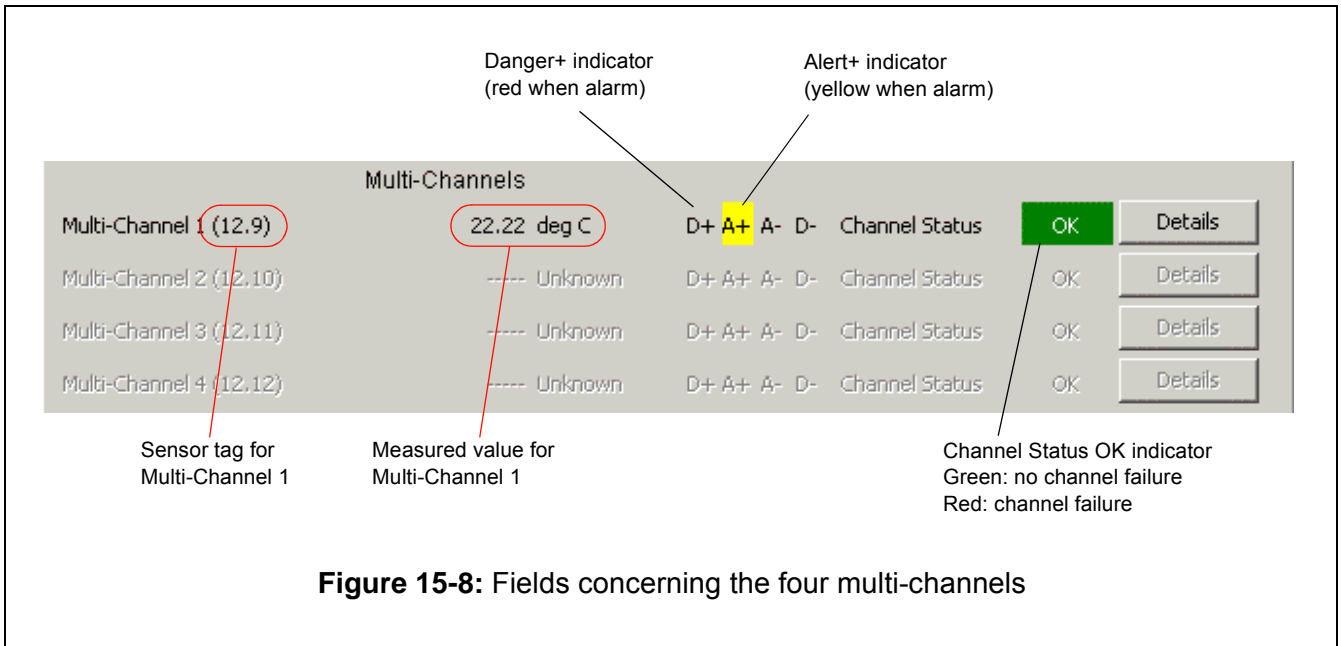

**15.8.1.3 Fields concerning basic and advanced logical combinations of alarms**

The AMC Outputs window shows the status of the 16 Basic and 8 Advanced logical combinations of alarms (Figure 15-9).

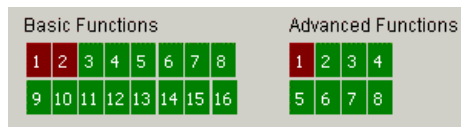

**Figure 15-9: Fields concerning the basic and advanced logical combinations of alarms**

The alarm flags have the following colour coding:

- Green, indicating there is no alarm
- Red, indicating an alarm.

**15.8.1.4 Fields concerning status information**

The MPC Outputs window shows information on common alarms as well as status information for diagnostics purposes.



**Figure 15-10: Fields concerning status information**

The **Status Latch** flag (Figure 15-10) has the following colour coding:

- Green, indicating no data has been latched since the last Clear Status Latch Data operation
- Red, indicating data has been latched.

See also 15.7 The status latch (clearing and reading).

The **DB** and **AR** flags are summarised in Table 15-3.

**Table 15-3:** Danger Bypass (DB) and Alarm Reset (AR) flags

Flag name	Description	Colour coding
DB	Danger Bypass indicator	Green: indicating DB or AR is not active Red: indicating DB or AR is active
AR	Alarm Reset indicator	

## 15.9 Resetting alarms (Alarm Reset)

Alarms indicated by the status indicators (LEDs) on the front panel of the AMC8 card, or on the AMC Outputs window, can be reset by selecting **To AMC** from the **Communications** menu and then choosing the **Alarm Reset** command.

## 15.10 Checking LEDs on the AMC8 front panel (Lamp Test)

All the status indicators (LEDs) on the front panel of the AMC8 card can be tested by selecting **To AMC** from the **Communications** menu and then choosing the **Lamp Test** command.

This action initiates a single test cycle that activates sequentially each possible colour of each multi-colour LED.

## 15.11 Checking the card status (Read System Status)

This menu command is mainly provided for troubleshooting purposes. In case of problems with a card, Meggitt Sensing Systems customer support may ask you to pass on to them certain information available from the VM600 MPS software (see Figure 15-11).

To view the card status, select **From AMC** from the **Communications** menu and then select the **Read System Status** command.

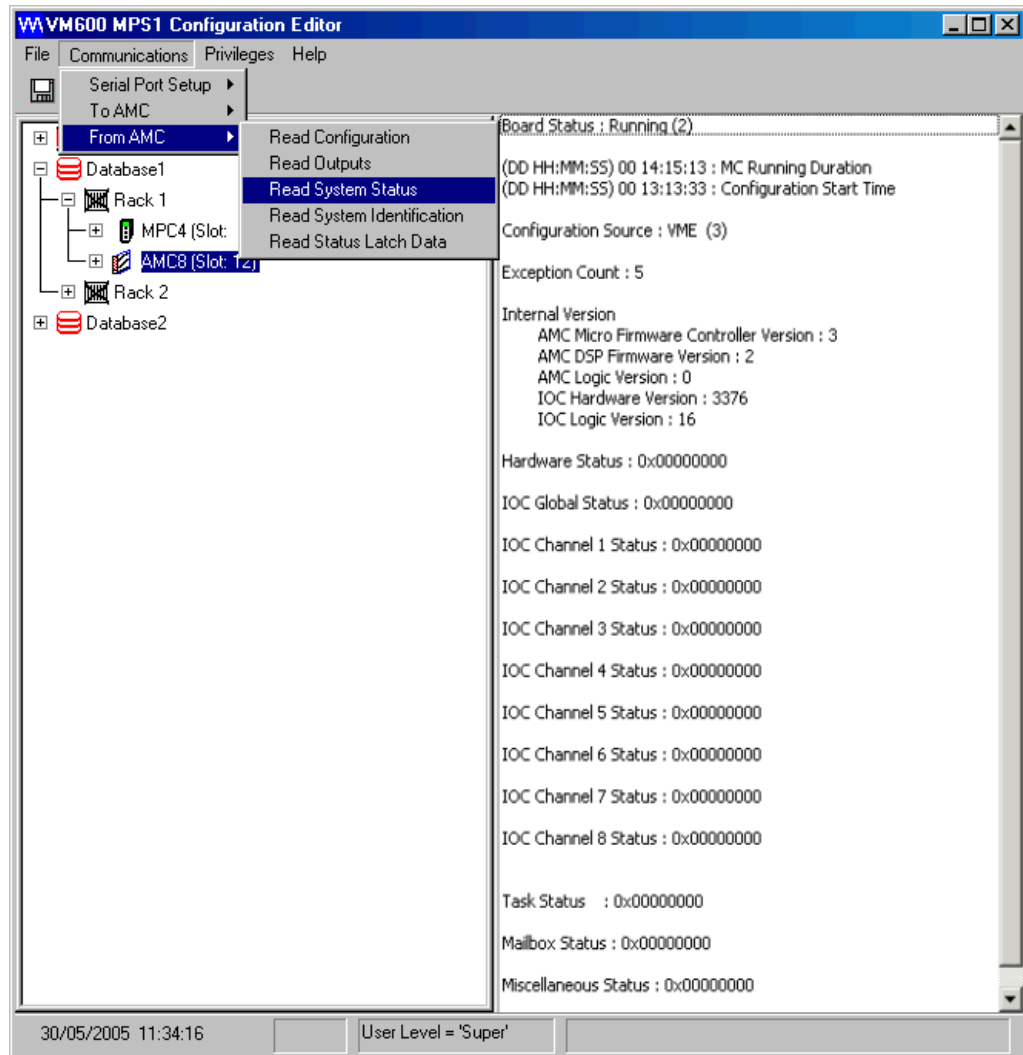

Figure 15-11: Read System Status window (AMC8 / IOC8T card pair)

## 15.12 Inhibiting a channel (Channel Inhibits)

The channel inhibit function allows individual AMC8 input channels and the processing associated with them to be temporarily bypassed.

The channel inhibit function is activated when one of the VM600 MPS software packages (MPS1 or MPS2) is used to send channel inhibit commands to individual AMC8 input channels. Alternatively, Modbus can be used to control the channel inhibit function for networked VM600 machinery protection systems (containing a CPUM card).

To activate the channel inhibit function for an AMC8 input channel or channels:

- 1- Click **Communications > To AMC > Channel Inhibits**.
- 2- Use the Channel Inhibits dialog box that appears to select the Channels for which the channel inhibit function is required. Then click **Send**.

The channel inhibit function is activated for the selected channels.

When the channel inhibit function is activated for a channel:

- Any processing channels that depend on the channel are also automatically bypassed.
- The power supply for the channel is turned off.
- An Inhibit On event is recorded in the database.
- The MPC outputs window displays the channel information with an “Inhibited” label and in grey coloured text (see 15.8 The AMC outputs window (Read Outputs)).
- The channel’s status indicator (LED) on the front panel of the AMC8 card slowly blinks green for the duration of the channel inhibit (approximately once per second).

Also, clicking **Communications > To AMC > Channel Inhibits** again will display the Channel Inhibits dialog box with the check boxes selected for each inhibited input channel.

---

**NOTE:** When an AMC8 card is configured (for example, using **Communications > To AMC > Send Configuration**), the channel inhibit function is automatically deactivated for any channels where it is active.

---

To de-activate the channel inhibit function for an AMC8 input channel or channels:

- 1- Click **Communications > To AMC > Channel Inhibits**.
- 2- Use the Channel Inhibits dialog box that appears to clear the Channels for which the channel inhibit function is no longer required. Then click **Send**.  
The channel inhibit function is de-activated for the cleared channels.

When the channel inhibit function is de-activated for a channel:

- The power supply for the channel is turned back on and the AMC8 card waits 2 seconds for signal stabilisation (in addition to the OK system check recovery time).
- Any latched alarms are reset (cleared) and the processing channels that depend on the channel resume normal operation.
- An Inhibit Off event is recorded in the database.
- The MPC outputs window displays the channel information as usual (see 15.8 The AMC outputs window (Read Outputs)).
- The channel’s status indicator (LED) on the front panel of the AMC8 card indicates the operational status of the card.

---

**NOTE:** Cards that support the channel inhibit function can coexist in a VM600 rack with cards (running older versions of firmware) that do not support this function. For cards that do not support the channel inhibit function, the VM600 MPS software will report the channel inhibit function as unavailable.

---

# Part V: Configuring the system at rack level

**THIS PAGE INTENTIONALLY LEFT BLANK**

# 16 CONFIGURATION WINDOWS AT RACK LEVEL

## 16.1 Introduction

This section is intended to help you navigate around the VM600 rack backplane. It describes the five tabs seen at rack level, that is, when a rack is selected in the configuration tree structure (see Figure 16-1):

- General Information      See 16.2 The general information tab.
- Backplane Bus View      See 16.3 The backplane bus view tab.
- Backplane Configuration      See 16.4 The backplane configuration tab.
- IOC Jumper Matrix      See 16.5 IOC jumper matrix and RLC jumper matrix tabs.
- RLC Jumper Matrix      See 16.5 IOC jumper matrix and RLC jumper matrix tabs.

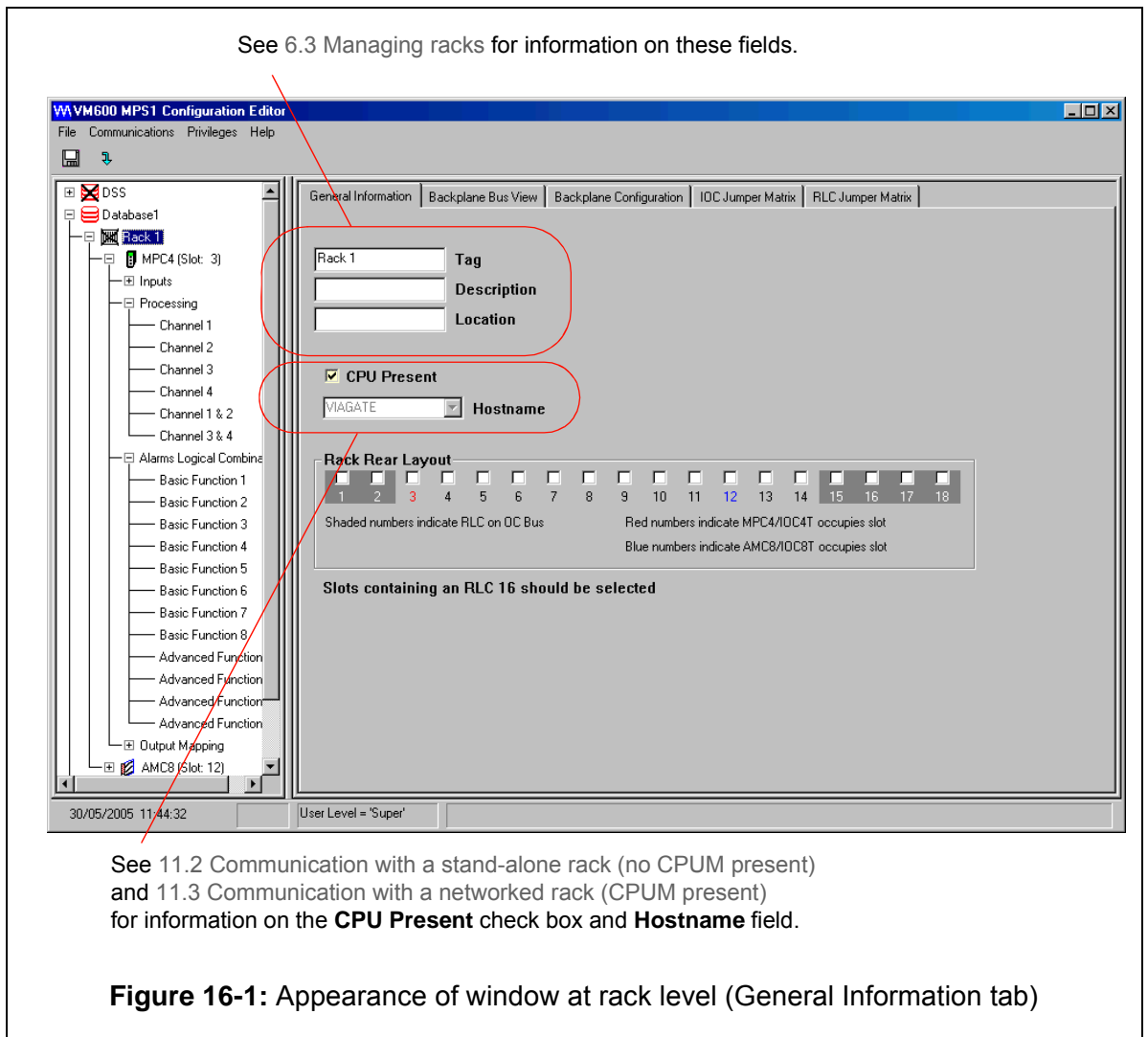

## 16.2 The general information tab

This section describes the check boxes under **Rack Rear Layout** (see Figure 16-1 and Figure 16-2). This area contains 18 check boxes. These represent slots 1 to 18 at the rear of the VM600 rack. These slots are intended to house various types of input/output cards (IOC4T, IOC8T) and relay cards (RLC16).

A slot number shown in red indicates that it is occupied by an MPC4 / IOC4T card pair (see Figure 16-1 and Figure 16-2, where slots 3 and 5 contain this type of card pair).

A slot number shown in blue indicates that it is occupied by an AMC8 / IOC8T card pair (see Figure 16-1 and Figure 16-2, where slots 7 and 9 contain this type of card pair).

Slots 1, 2, 15, 16, 17 and 18 (shown on a dark grey background) have special significance. An RLC16 card housed in any one of these slots can be communicated with over the OC Bus under certain conditions. For example, a card pair in slot 5 or 6 can switch relays on an RLC16 card in slot 2 using the OC Bus. See Figure 16-3 and refer to the *VM600 Machinery Protection System (MPS)* hardware manual for further information.

**NOTE:** It is very important to identify the slots that contain an RLC16 card by selecting (clicking) the corresponding check boxes (for example, in Figure 16-2 slots 1, 2 and 4 contain an RLC16 card).

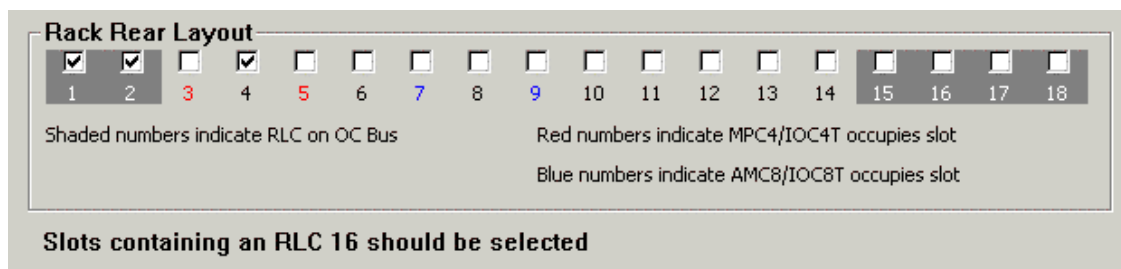

**Figure 16-2:** Rack Rear Layout area of the General Information tab

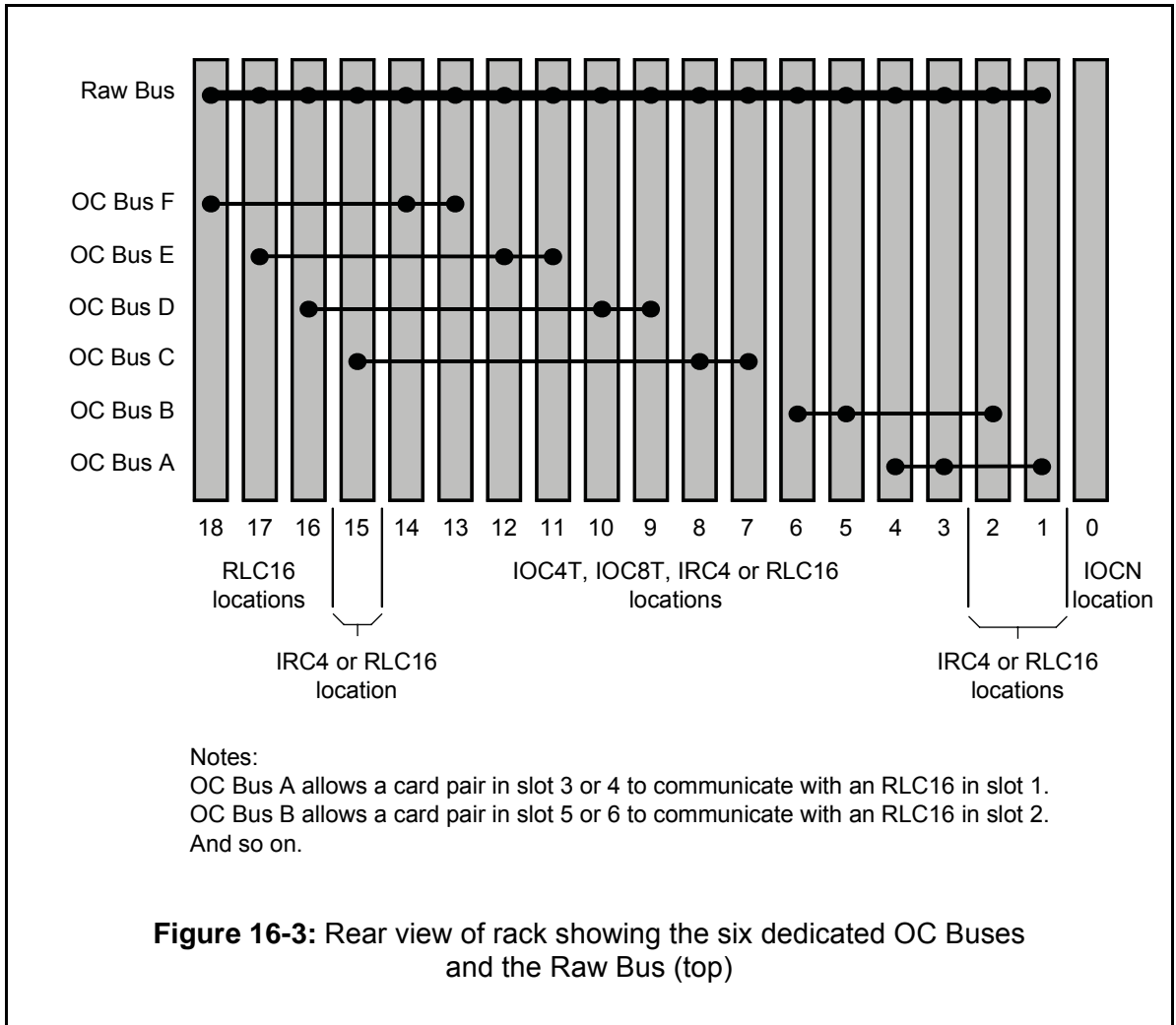

**Figure 16-3:** Rear view of rack showing the six dedicated OC Buses and the Raw Bus (top)

### 16.3 The backplane bus view tab

This read-only tab (Figure 16-4) provides information at a glance on the VM600 rack's three internal buses. This section shows how this tab relates to information entered on other windows.

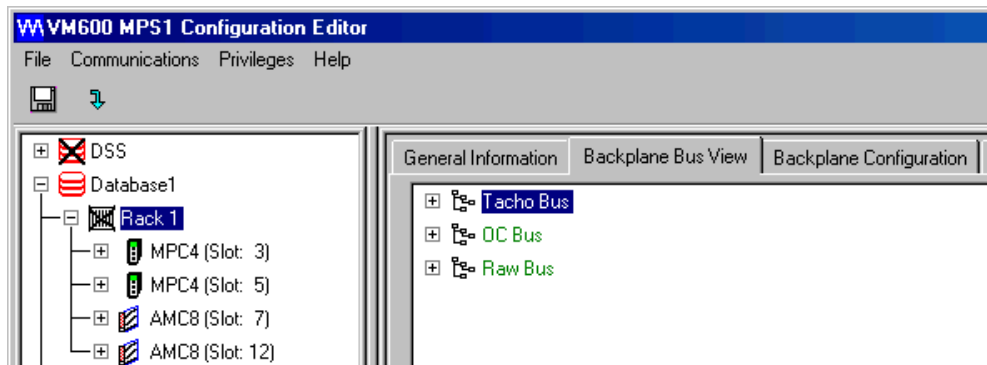

**Figure 16-4:** Backplane Bus View showing the three buses

### 16.3.1 The Tacho Bus branch

Speed signals can be put onto a Tacho Bus line by selecting a destination in the **Tachometer Output** field. This is visible when a speed channel is selected in the configuration tree structure. See the example in Figure 16-5 (a).

A speed signal can be picked off a Tacho Bus line using the **Sensor Connected** field. This is visible when a speed channel is selected in the configuration tree structure. See the example in Figure 16-5 (b).

The routing of speed signals over the Tacho Bus is summarised in the Backplane Bus View, as shown in Figure 16-5 (c).

Unused bus lines are shown in green.

Tacho Bus lines 7 and 8 are reserved for routing cold-junction compensation (CJC) signals between AMC8 cards in the rack and cannot be used for speed signals.

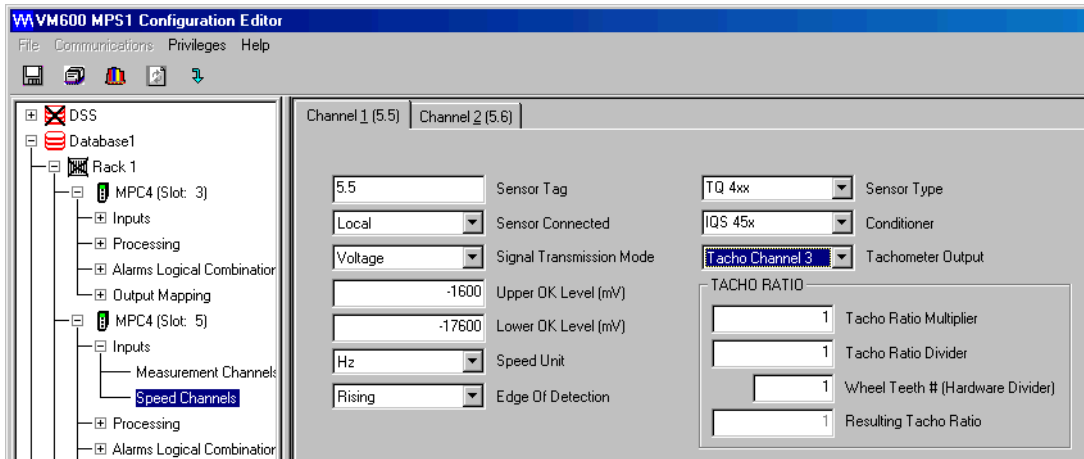

- a. Placing the signal obtained on Speed Channel 2 (TACHO 2) of the MPC4 card in slot 5 of Rack A onto Tacho Channel 3 (that is, line 3 of the Tacho Bus)

- a. Using the signal on Remote Channel 3 (that is, line 3 of the Tacho Bus) as the speed input for Channel 2 of the MPC4 card in slot 3 of Rack A

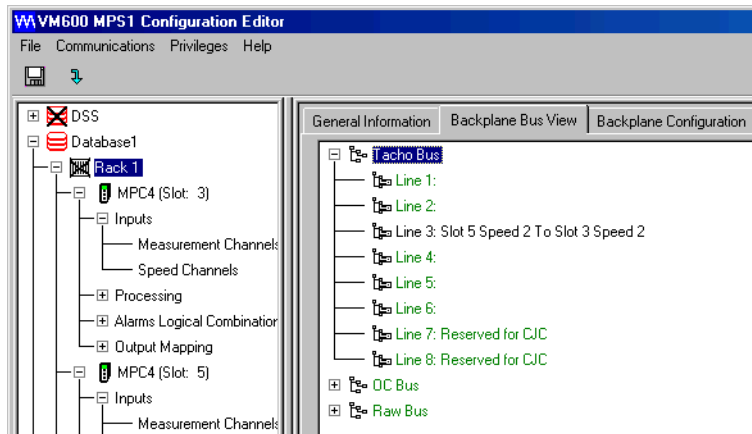
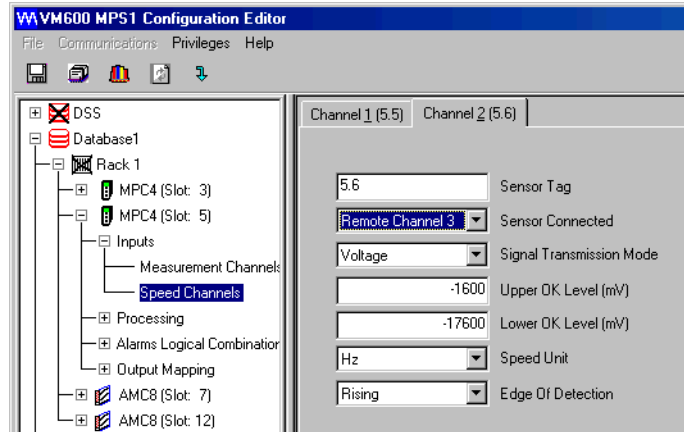

- a. How this configuration is represented on the Backplane Bus View tab

Figure 16-5: Signals on the Tacho Bus

### 16.3.2 The OC Bus branch

Signals can be put on to the OC Bus by selecting the Output Mapping \ Discrete Outputs branch of the configuration tree structure, as shown in Figure 16-6 (a). The software automatically selects the appropriate OC Bus among the six that exist (OC Bus A to OC Bus F). For example, in Figure 16-6, OC Bus A is selected because the signal originates on the card pair in slot 3. This links slot 3 to the RLC16 card in slot 1 (see Figure 16-3).

The Backplane Bus View allows you to see which of the 16 OC Bus lines are free. These are indicated in green, as shown in Figure 16-6 (b).

Choose a free OC Bus line for the signal. There is a direct correspondence between the line chosen and the number of the relay on the target RLC16 card. In this example, choosing OC Bus line 2 allows Relay 2 on the RLC16 card in slot 1 to be controlled by the signal.

Figure 16-6 (a) shows how to attribute the alarm signal “Measurement Channel 1, Output 1, Danger+ High” to line 2. This setting can be checked on the Backplane Bus View tab as shown in Figure 16-6 (b). This shows that Relay 2 is controlled by the signal having the code “V11D+”.

See Table 16-1 for the definition of all codes that can be found on this tab. The table shows how the fields were set up when the Output Mapping \ Discrete Outputs branch of the configuration tree structure was selected (see Figure 16-6 (a)).

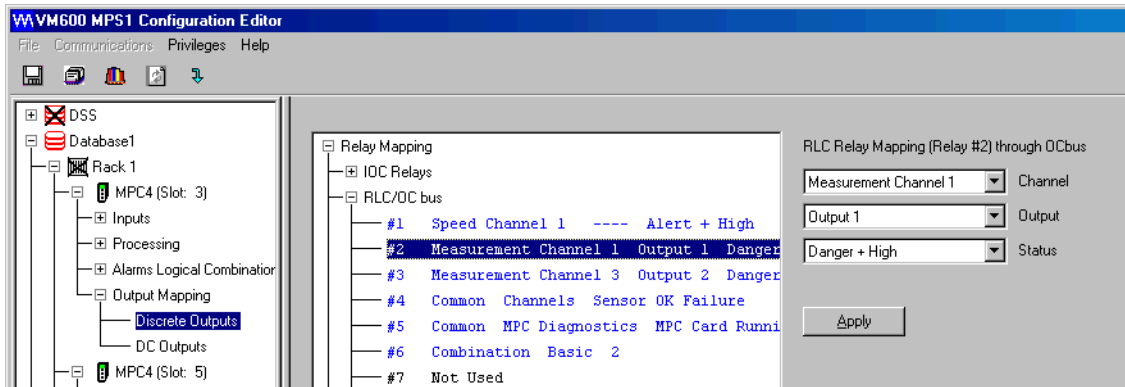

- a. Attributing the alarm signal “Measurement Channel 1, Output 1, Danger+ High” to line 2 on the OC Bus (OC Bus A, which links slots 3 and 4 to the RLC card in slot 1)

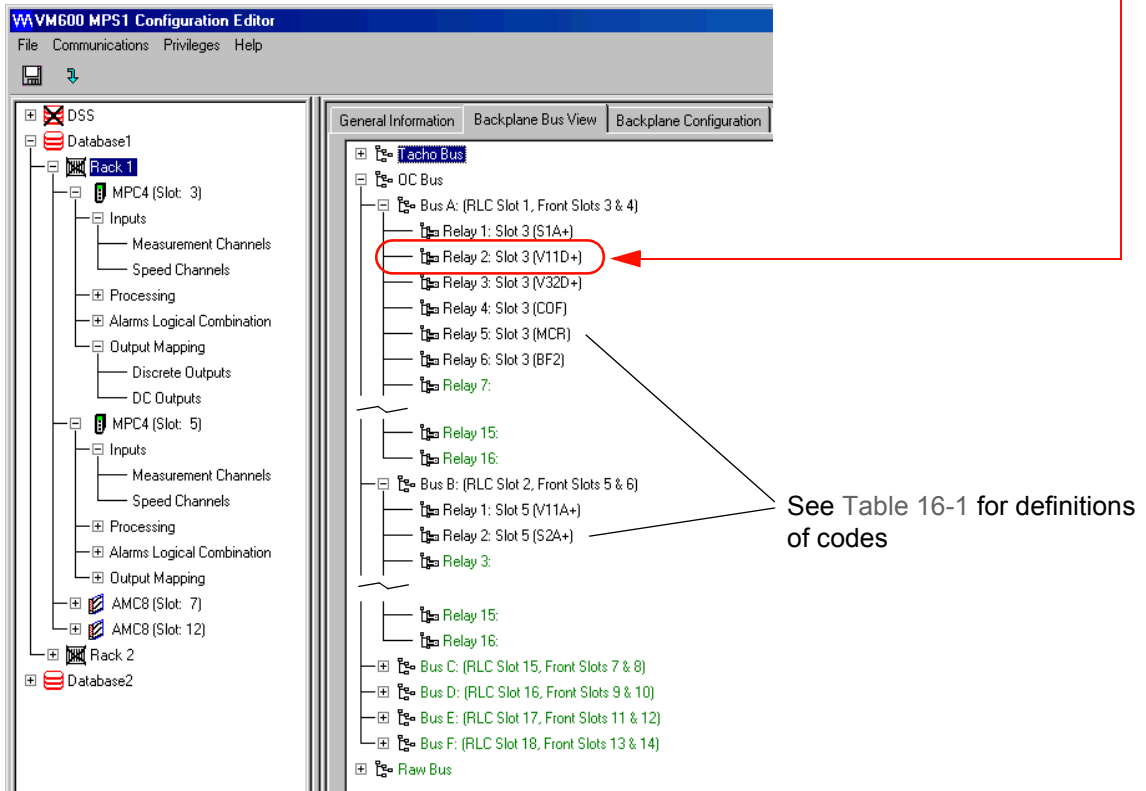

- a. Typical configuration on the Backplane Bus View tab

Figure 16-6: Signals on the OC Bus

**Table 16-1:** Definition of codes seen in the OC Bus branch of the backplane bus view (Part 1 of 3)

Code in Bus View	Card type	Configuration of fields when Output Mapping \ Discrete Outputs branch selected		
AFn	MPC4	Combination	Advanced Function	Number n (n = 1 to 4)
AFn	AMC8	Advanced Logical Combination		Function n (n = 1 to 8)
Alarm Reset	AMC8	Common Status		Alarm Reset
AMC Not Running	AMC8	Common Status		AMC Configuration Not Running
AR	MPC4	Common	Controls	Alarm Reset
BFn	MPC4	Combination	Basic Function	Number n (n = 1 to 8)
BFn	AMC8	Basic Logical Combination		Function n (n = 1 to 16)
CA	MPC4	Common	Channels	Alert
CCME	MPC4	Common	Signal Diagnostics	Common Mode Overflow
CD	MPC4	Common	Channels	Danger
CDSE	MPC4	Common	MPC Diagnostics	DSP Saturation Error
CHn A-	AMC8	Channel n (n = 1 to 8)		Alarm-
CHn A+	AMC8	Channel n (n = 1 to 8)		Alarm+
CHn D-	AMC8	Channel n (n = 1 to 8)		Danger-
CHn D+	AMC8	Channel n (n = 1 to 8)		Danger+
CHn Global OK Fail	AMC8	Channel n (n = 1 to 8)		Global Channel OK Fail
CIE	MPC4	Common	Signal Diagnostics	Input Signal Error
CISE	MPC4	Common	Signal Diagnostics	Input Saturation Error
CMF	MPC4	Common	MPC Diagnostics	Monitoring Failure
COF	MPC4	Common	Channels	Sensor OK Failure
CPE	MPC4	Common	MPC Diagnostics	Processing Error

**Table 16-1:** Definition of codes seen in the OC Bus branch of the backplane bus view (Part 2 of 3)

Code in Bus View	Card type	Configuration of fields when Output Mapping \ Discrete Outputs branch selected		
CSOL	MPC4	Common	Track/Speed Diagnostics	Speed out of Limit
CTL	MPC4	Common	Track/Speed Diagnostics	Track Lost
CTOR	MPC4	Common	Track/Speed Diagnostics	Track out of Limit
D12A-	MPC4	(Dual) Measurement Channel 1 & 2	Output 1	Alert- Low
D12A+	MPC4	(Dual) Measurement Channel 1 & 2	Output 1	Alert+ High
D12D-	MPC4	(Dual) Measurement Channel 1 & 2	Output 1	Danger- Low
D12D+	MPC4	(Dual) Measurement Channel 1 & 2	Output 1	Danger+ High
D12ERR	MPC4	(Dual) Measurement Channel 1 & 2	Output 1	Invalid
D12PGA	MPC4	(Dual) Measurement Channel 1 & 2		PGA Saturation Error
D12SOK	MPC4	(Dual) Measurement Channel 1 & 2		SOK Level
D34...	MPC4	(Dual) Measurement Channel 3 & 4	Output 1	... (as for Dual Channel 1 & 2)
Danger Bypass	AMC8	Common Status		Danger Bypass
DBP	MPC4	Common	Controls	Danger Bypass
DTM	MPC4	Common	Controls	Direct Trip Multiply
MCHn Global OK Fail	AMC8	Multi-Channel n (n = 1 to 4)		Global Channel OK Fail
MCHn A-	AMC8	Multi-Channel n (n = 1 to 4)		Alarm-
MCHn A+	AMC8	Multi-Channel n (n = 1 to 4)		Alarm+
MCHn D-	AMC8	Multi-Channel n (n = 1 to 4)		Danger-
MCHn D+	AMC8	Multi-Channel n (n = 1 to 4)		Danger+

**Table 16-1:** Definition of codes seen in the OC Bus branch of the backplane bus view (Part 3 of 3)

Code in Bus View	Card type	Configuration of fields when Output Mapping \ Discrete Outputs branch selected		
MCR	MPC4	Common	MPC Diagnostics	MPC Card Running
S1A-	MPC4	Speed Channel 1		Alert- Low
S1A+	MPC4	Speed Channel 1		Alert+ High
S1ERR	MPC4	Speed Channel 1		Invalid
S1SOK	MPC4	Speed Channel 1		SOK Level
S2...	MPC4	Speed Channel 2		... (as for Speed Channel 1)
SL	MPC4	Common	MPC Diagnostics	Status Latch / Error Log
Status Latched	AMC8	Common Status		Status Latched
V11A-	MPC4	Measurement Channel 1	Output 1	Alert- Low
V11A+	MPC4	Measurement Channel 1	Output 1	Alert+ High
V11D-	MPC4	Measurement Channel 1	Output 1	Danger- Low
V11D+	MPC4	Measurement Channel 1	Output 1	Danger+ High
V11ERR	MPC4	Measurement Channel 1	Output 1	Invalid
VnPGA	MPC4	Measurement Channel n (n = 1 to 4)		PGA Saturation Error
VnSOK	MPC4	Measurement Channel n (n = 1 to 4)		SOK Level
V12...	MPC4	Measurement Channel 1	Output 2	... (as for Channel 1, Output 1)
V21...	MPC4	Measurement Channel 2	Output 1	... (as for Channel 1, Output 1)
V22...	MPC4	Measurement Channel 2	Output 2	... (as for Channel 1, Output 1)
V31...	MPC4	Measurement Channel 3	Output 1	... (as for Channel 1, Output 1)
V32...	MPC4	Measurement Channel 3	Output 2	... (as for Channel 1, Output 1)
V41...	MPC4	Measurement Channel 4	Output 1	... (as for Channel 1, Output 1)
V42...	MPC4	Measurement Channel 4	Output 2	... (as for Channel 1, Output 1)

### 16.3.3 The Raw Bus branch

The raw signal entering each channel of an MPC4 / IOC4T card pair can be placed on the Raw Bus for use by other cards in the VM600 rack.

The Raw Bus contains 32 pairs of lines for this purpose. These pairs have one line defined as “High” and the other as “Low”.

To attribute a pair of lines to a particular card and channel:

- 1- Select the rack in the configuration tree structure as shown in Figure 16-7 (a).
- 2- Select the Backplane Configuration tab.
- 3- Select the slot number and channel number from the Raw Signals / Raw Bus branch of the tree structure.
- 4- Pick a pair of lines from those proposed in the **Raw Signal Attribution Lines** combo box. The software automatically displays only the possibilities that are allowed by the hardware configuration.
- 5- Click the **Apply** button.

Figure 16-7 (a) shows how the raw signal on Channel 2 of the card pair in slot 5 can be placed on Raw Bus line pair “37 - 5”.

Figure 16-7 (b) shows how this appears on the Backplane Bus View tab. Lines 5 and 37 are identified as Raw Signal Low and Raw Signal High, respectively.

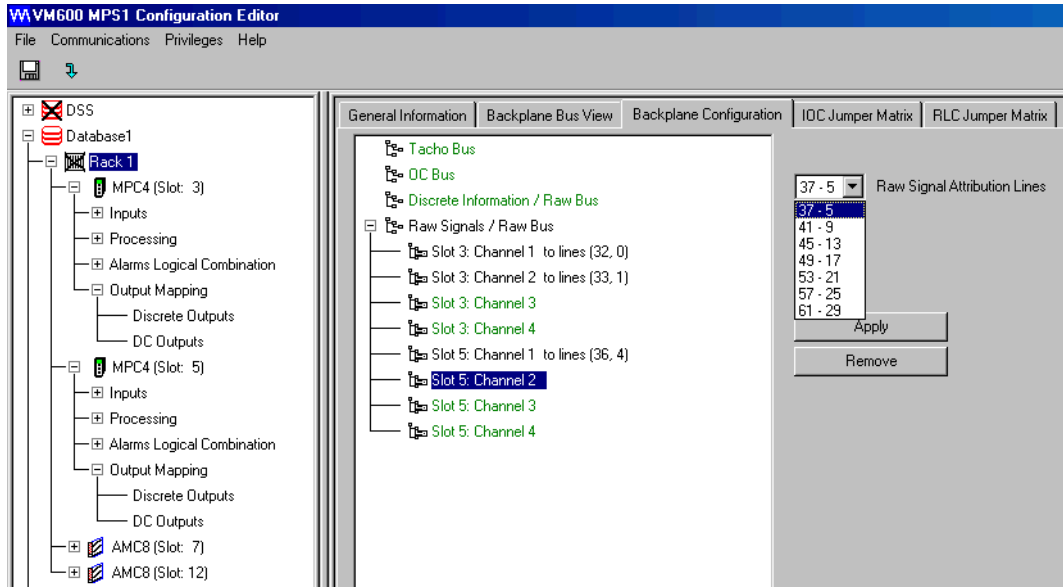

a. Attributing the signal on Channel 2 of the card in slot 5 to the Raw Bus line pair “37 - 5”

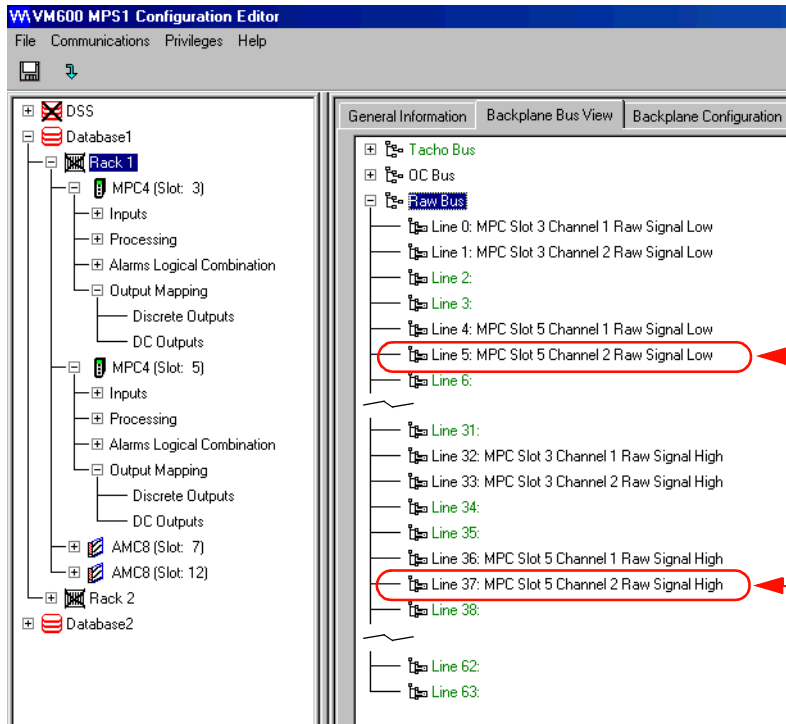

b. How this configuration appears on the Backplane Bus View tab

Figure 16-7: Signals on the Raw Bus

## 16.4 The backplane configuration tab

### 16.4.1 The Tacho Bus branch

This read-only branch of the tree structure shows the signals on the Tacho Bus.

Figure 16-8 shows the appearance of the Tacho Bus branch if the software is configured as described in the example given in Figure 16-5.

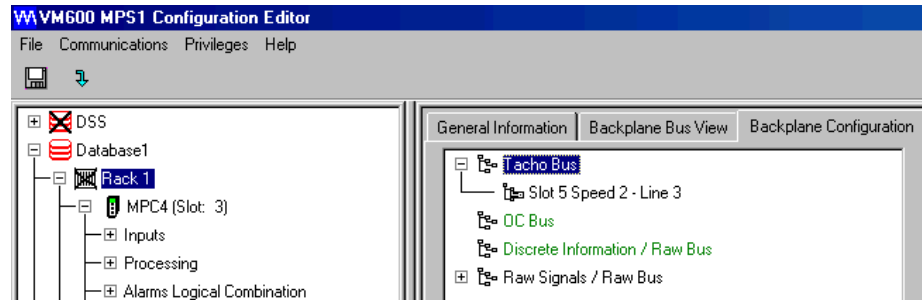

**Figure 16-8:** Tacho Bus branch

### 16.4.2 The OC Bus branch

Figure 16-9 shows the appearance of the OC Bus branch if the software is configured as described in the example given in Figure 16-6.

This branch of the tree structure allows the polarity of a relay on an RLC16 card to be set, as follows:

- 1- Select a signal from the OC Bus branch of the tree structure.  
The example in Figure 16-9 shows how to select the signal driving Relay 2 on the RLC16 card in slot 1.
- 2- Select the desired polarity from the **Relay Polarity** combo box:
  - NDE = Relay normally de-energised
  - NE = Relay normally energised.
- 3- Click the **Apply** button.

The setting of each relay is shown in brackets at the end of each line.

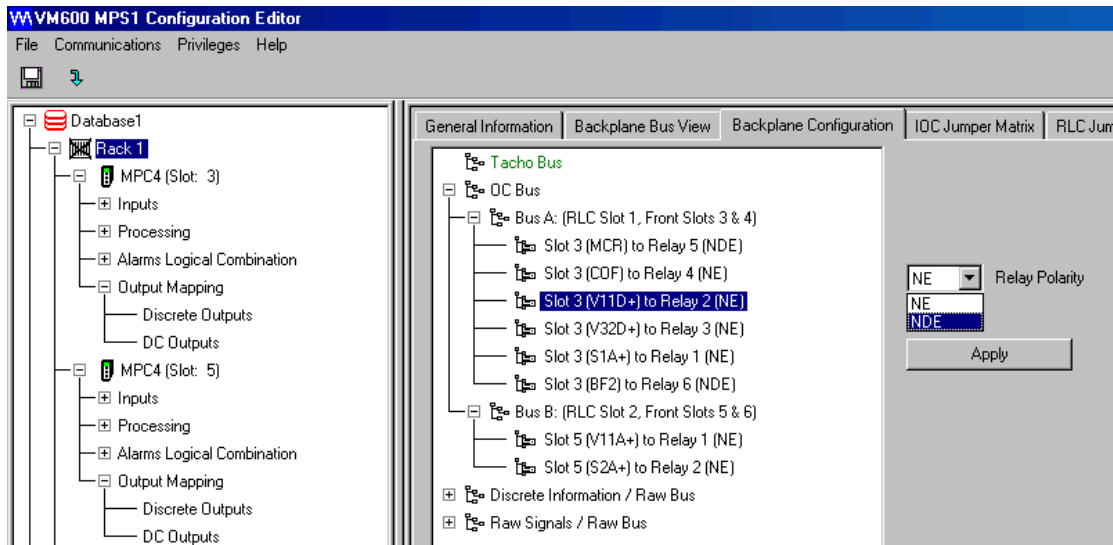

Figure 16-9: Defining relay characteristics for signals using the OC Bus

### 16.4.3 The discrete information / Raw Bus branch

Relays on an RLC16 card can be controlled over the Raw Bus, as well as over the OC Bus as previously described.

To place a relay control signal on the Raw Bus:

- 1- Select the Output Mapping / Discrete Outputs branch of the configuration tree structure, as shown on the left of Figure 16-10 (a).
- 2- Open the Relay Mapping / RLC / Raw Bus branch of the tree structure appearing on the right of the window.  
This branch lists 16 bus lines, identified as #1 to #16. There is a direct correspondence between the line number and the number of the relay on the target RLC16 card.
- 3- Select the line that corresponds to the number of the relay you want to switch, for example select line #3 for Relay 3.
- 4- Attribute a signal to the line using the combo boxes on the right of the window.
- 5- Click the **Apply** button.

To configure the relay control signal:

- 1- Select the rack in the main configuration tree structure, as shown in Figure 16-10 (b).
- 2- Select the Backplane Configuration tab and open up the Discrete Information / Raw Bus branch of the tree structure.
- 3- Select the line corresponding to the relay control signal. These signals are identified by a code such as "V32A+" (see Table 16-1 for a definition of all possible codes).
- 4- Select the target RLC16 card from the **RLC Destination Slots** combo box. This lists the slot numbers of all RLC16 cards defined for the rack. For example, if the **Rack Rear**

**Layout** check boxes are set up as shown in Figure 16-2, only slots 1, 2 and 4 are shown in the list.

- 5- Select a bus line from the **Discrete Info Attribution Line** combo box. The software automatically proposes only the bus lines that are relevant to the relay number in question, but care must be taken to avoid putting conflicting signals on the same bus line. See 16.4.3.1 Avoiding signal conflicts on the same bus line below.
- 6- Select the desired polarity from the **Relay Polarity** combo box:
  - NDE = Relay normally de-energised
  - NE = Relay normally energised.
- 7- Click the **Apply** button.

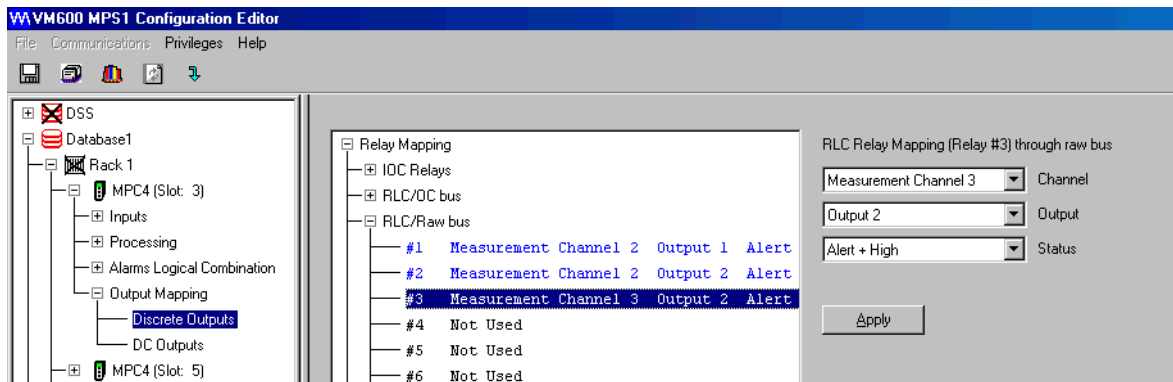

a. Attributing the alarm signal “Measurement Channel 3, Output 2, Alert+ High” to line 3 on the Raw Bus. This allows Relay 3 to be controlled on a given RLC16 card.

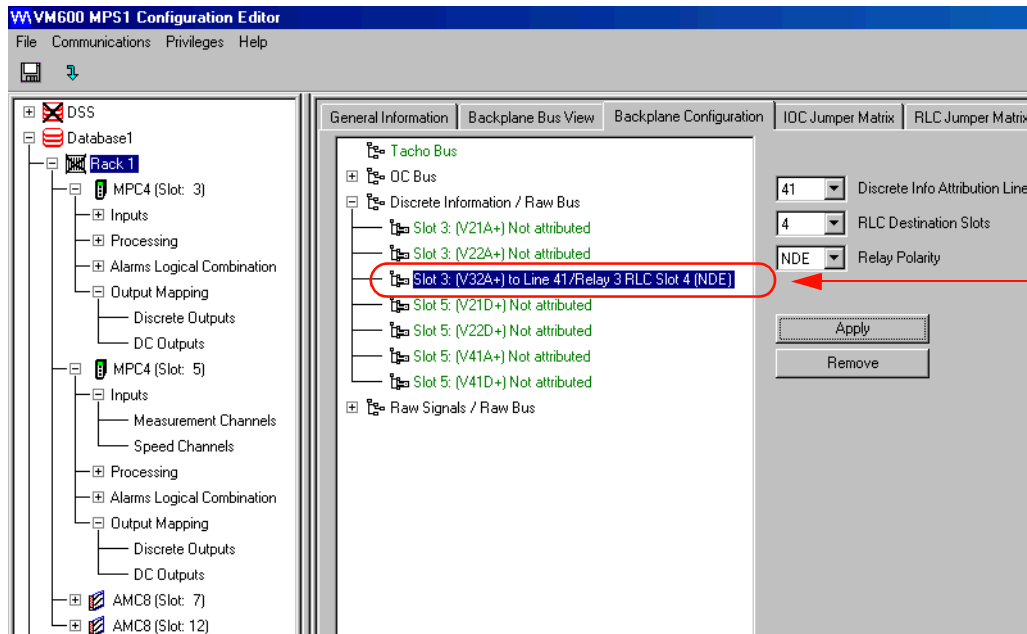

b. Typical configuration on the Backplane Configuration tab

**Figure 16-10: Signals on the OC Bus**

### 16.4.3.1 Avoiding signal conflicts on the same bus line

It is important to avoid creating signal conflicts on the same bus line. An example is shown in Figure 16-11.

As seen in Figure 16-11 (a), line 41 is already used to switch Relay 3 on the RLC16 card in slot 4. The control signal has the code “V32A+” and it originates in slot 3.

The control signal “V41A+”, which originates in slot 5, is intended to switch Relay 3 on the RLC16 card in slot 1.

When the **RLC Destination Slots** field is set to “1”, the first entry in the **Discrete Info Attribution Line** field shows “41”. This value must not be applied as it will cause a signal conflict on bus line 41. You must select an alternative value (49 or 57) from the combo box as shown in Figure 16-11 (b).

### 16.4.4 The raw signals / Raw Bus branch

See 16.3.3 The Raw Bus branch for a description of this branch.

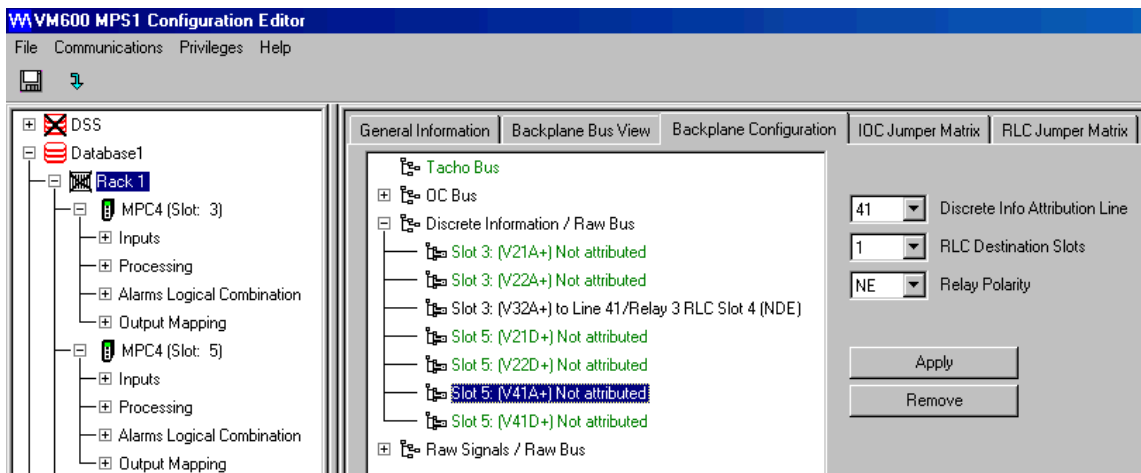

- a. Configuring the signal “V41A+” to switch Relay 3 on the card in slot 1. Line 41 is proposed, but this line is already used for the signal “V32A+”.

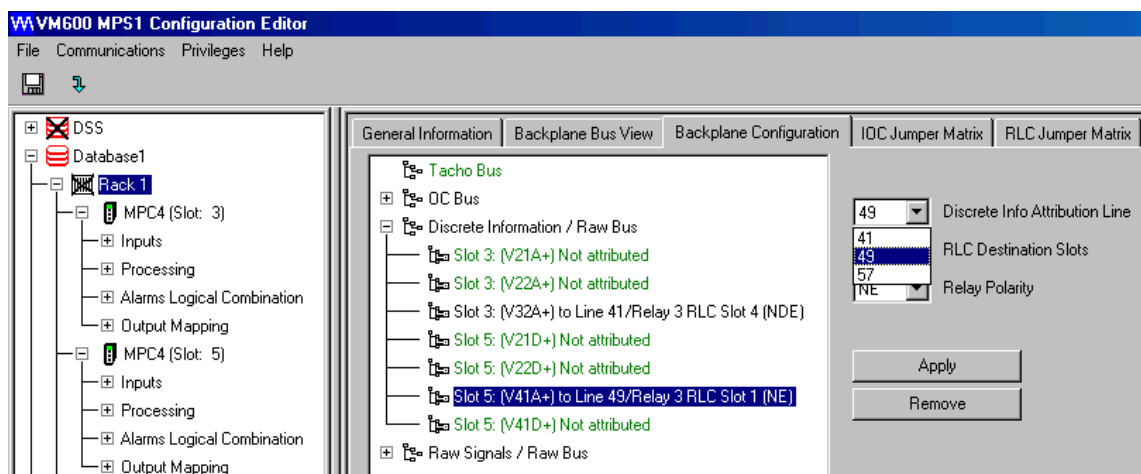

- b. Select an alternative line (49 or 57) from the combo box.

**Figure 16-11:** Avoiding signal conflicts on the same Raw Bus line

## 16.5 IOC jumper matrix and RLC jumper matrix tabs

These tabs provide a pictorial representation of how jumpers should be set on the IOC4T, IOC8T and RLC16 cards in the rack. See the examples shown in Figure 16-13 to Figure 16-15. A tab is present for each IOC and RLC card installed in the rack.

### 16.5.1 Using the shortcut menu

Place the mouse pointer over the jumper matrix diagram and click the right mouse button to obtain the shortcut menu shown in Figure 16-12.

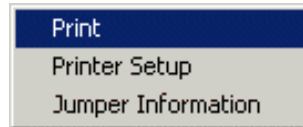

**Figure 16-12:** shortcut menu for jumper matrix windows

This menu has the following three commands:

<b>Print</b>	Prints out the diagram that is displayed on the screen.
<b>Printer Setup</b>	Allows you to choose a printer and set up the printer properties.
<b>Jumper Information</b>	Opens a relay map summary window. See 16.5.2 Jumper information (Relay Map Summary).

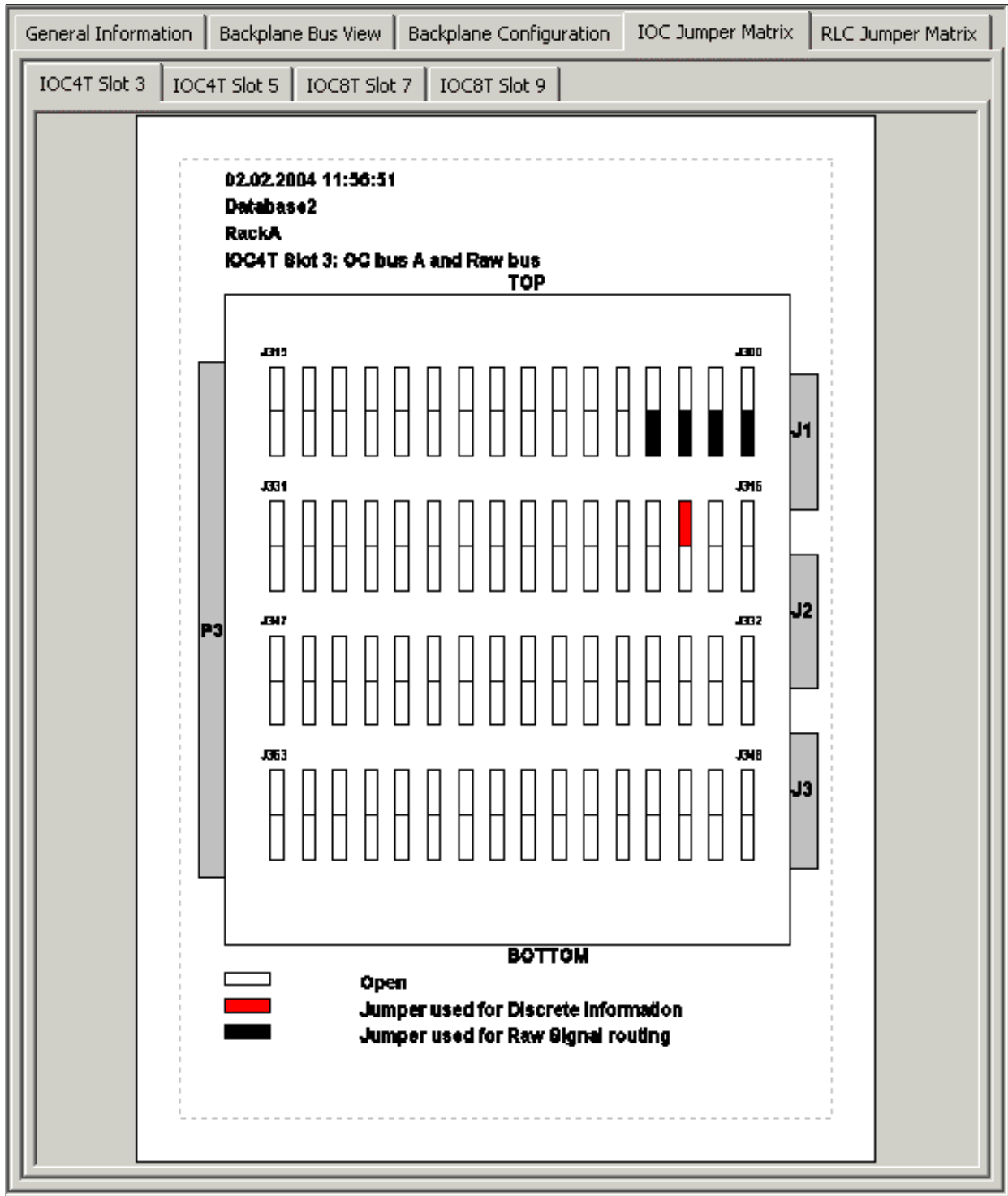
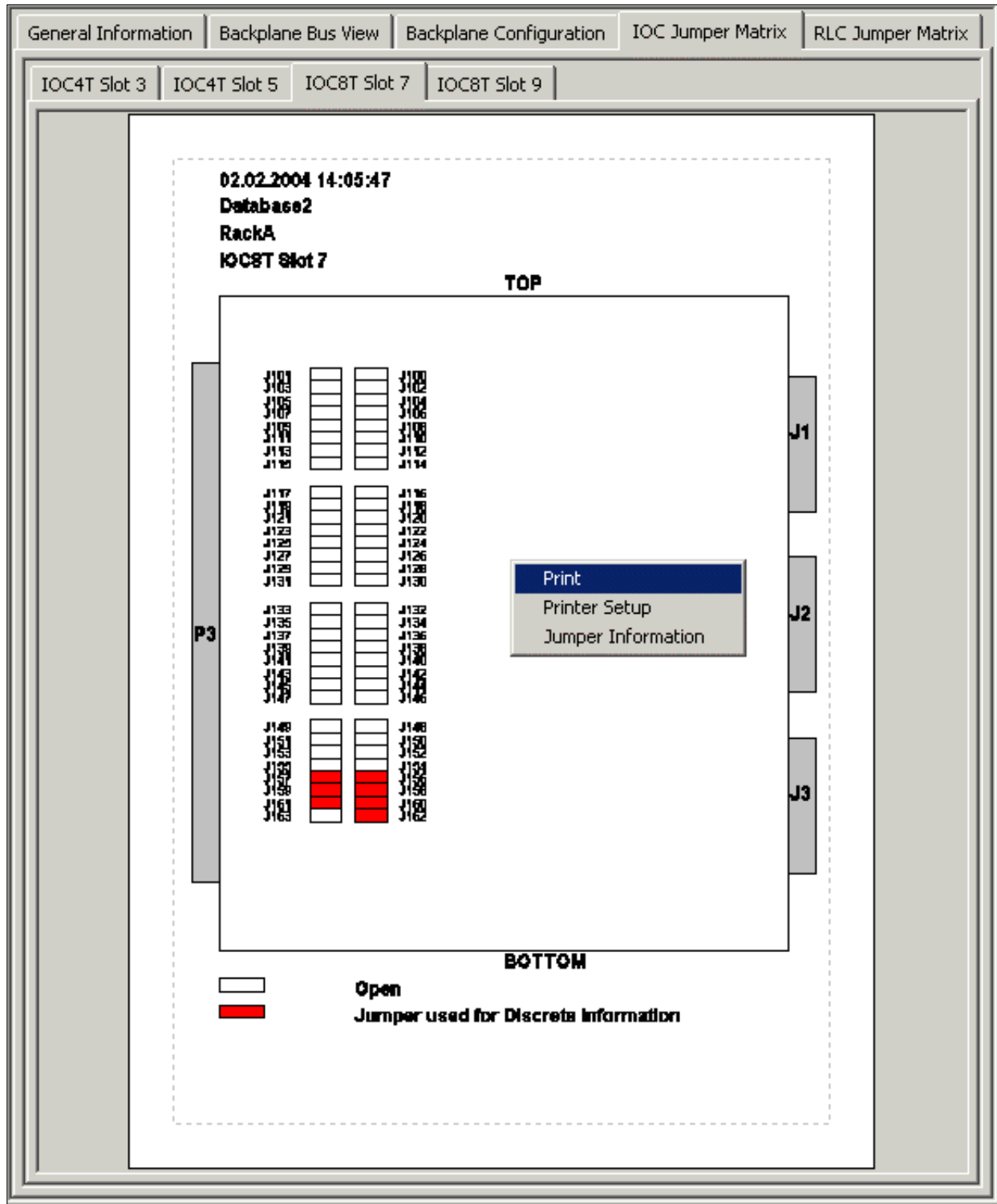

Figure 16-13: Typical jumper matrix for an IOC4T card

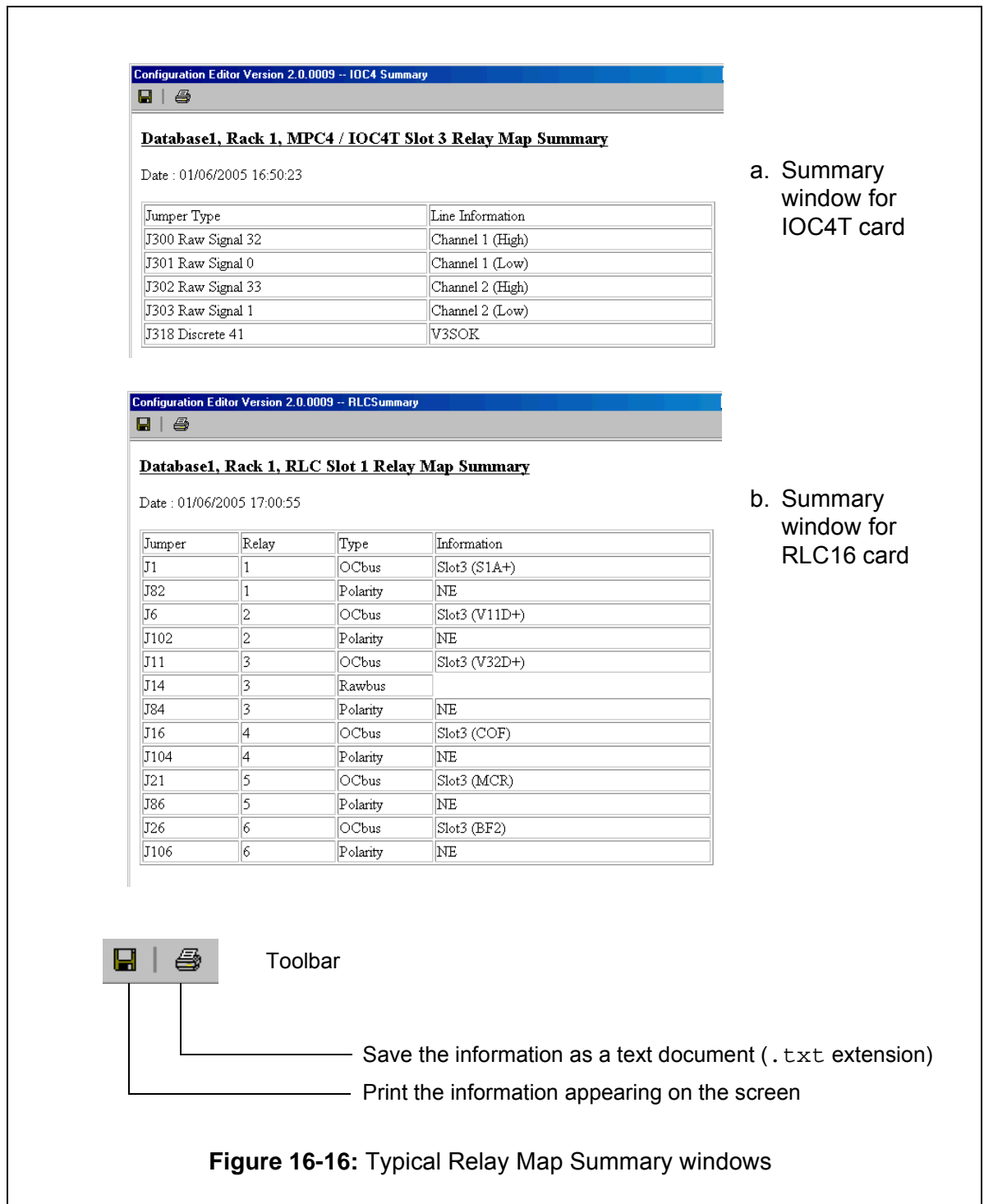

**Figure 16-14:** Typical jumper matrix for an IOC8T card (also showing the shortcut menu to print the diagram)



### 16.5.2 Jumper information (Relay Map Summary)

A Relay Map Summary window appears when the **Jumper Information** command is chosen from the shortcut menu. A typical example for an IOC4T card is shown in Figure 16-16.



**Figure 16-16: Typical Relay Map Summary windows**

**THIS PAGE INTENTIONALLY LEFT BLANK**

## 17 CUSTOMER SUPPORT

### 17.1 Contacting us

Meggitt Sensing Systems' worldwide customer support network offers a range of support including 17.2 Technical support and 17.3 Sales and repairs support. For customer support, contact your local Meggitt Sensing Systems representative. Alternatively, contact our main office:

Customer support  
Meggitt SA  
Route de Moncor 4  
PO Box 1616  
CH-1701 Fribourg  
Switzerland

Telephone: +41 (0)26 407 11 11  
Email: [energysupport@ch.meggitt.com](mailto:energysupport@ch.meggitt.com)  
Web: [www.meggittsensingsystems.com](http://www.meggittsensingsystems.com)

### 17.2 Technical support

Meggitt Sensing Systems' technical support team provide both pre-sales and post-sales technical support, including:

- 1- General advice
- 2- Technical advice
- 3- Troubleshooting
- 4- Site visits.

---

**NOTE:** For further information, contact Meggitt Sensing Systems (see 17.1 Contacting us).

---

### 17.3 Sales and repairs support

Meggitt Sensing Systems' sales team provide both pre-sales and post-sales support, including advice on:

- 1- New products
- 2- Spare parts
- 3- Repairs.

---

**NOTE:** If a product has to be returned for repairs, then it should be accompanied by a completed Failure report form, included on page 17-3.

---

## 17.4 Customer feedback

As part of our continuing commitment to improving customer service, we warmly welcome your opinions. To provide feedback, complete the Customer feedback form on page 17-5 and return it Meggitt Sensing Systems' main office (see 17.1 Contacting us).

# FAILURE REPORT FORM

If the product has to be returned to Meggitt Sensing Systems for repairs, then:

- 1- Complete this failure report form.
- 2- Attach a photocopy of this report to the faulty unit and retain the original copy for your records.
- 3- Send the product together with the attached failure report form to Meggitt SA by registered post.

---

**NOTE:** Please provide as much information as possible in order to assist fault diagnosis.

---



---

**NOTE:** A failure report must be sent with each faulty product.

---

**Contact details:**

Name \_\_\_\_\_ Job title \_\_\_\_\_

Company \_\_\_\_\_ Email \_\_\_\_\_

Address \_\_\_\_\_

Country \_\_\_\_\_ Post code \_\_\_\_\_

Telephone \_\_\_\_\_ Fax \_\_\_\_\_

Signature \_\_\_\_\_ Date \_\_\_\_\_

**Product details:**

Product type: \_\_\_\_\_

Serial number (S/N): \_\_\_\_\_ Part number (P/N): \_\_\_\_\_

Meggitt SA order number: \_\_\_\_\_

Date of purchase: \_\_\_\_\_ Site where installed: \_\_\_\_\_

**Is the failure** (put an  where appropriate):

- Continuous?                       Intermittent?                       Temperature dependent?

**Description of failure:**

\_\_\_\_\_

\_\_\_\_\_

\_\_\_\_\_

\_\_\_\_\_

\_\_\_\_\_

*(Continue overleaf)*





