

Intelligent Relay Card

The IRC 4 is a jumperless card driven by a modern 16 bits micro controller. This product can process complex equations up to 86 Discrete Inputs coming from all the MPC/AMC cards of a VM600 rack. Its high level of configuration makes it ideal to handle 2oo3 voting.

FEATURES

- 8 relays can be combined as 4 DPDT or 8 SPDT
- Each relay is controlled by a specific logic equation, which can be a combination of AND, OR, NOT or VOTE (x between y) operators
- Each relay can be latched; reset is set by a external DSI or by a specific equation
- 64 Raw Bus lines, 16 OC Bus lines and 6 external DSI can be used as terms of the equations
- Each relay can be set to NE or NDE
- Delays can be set on each relay to ensure glitch-free operation
- 4 external DSI can be used as general purpose input for the logic equations
- AR and DB external DSI act as Alarm Reset (Latch reset) and Danger Bypass
- Fully software configurable
- Non volatile configuration
- Screw terminal strip (32 terminals)
- Ensures EMI protection for all inputs and outputs
- Live insertion / removal of card possible

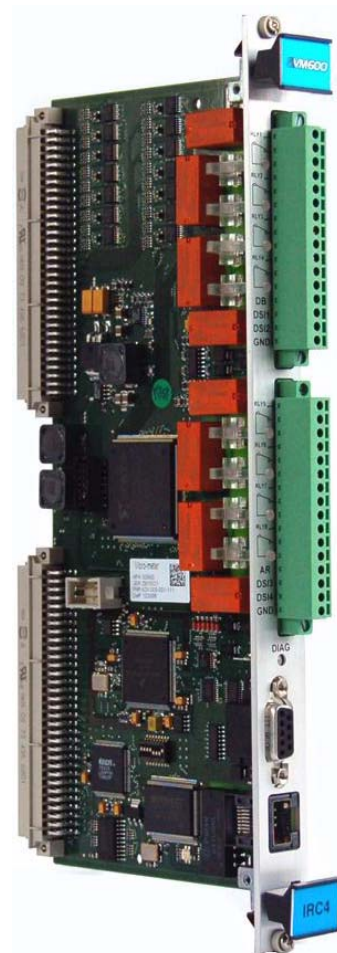

The information contained in this document may be subject to export control regulations of the European Community, USA or other countries. Each recipient of this document is responsible for ensuring that the transfer or use of any information contained in this document complies with all relevant export control regulations. ECN N/A.

DESCRIPTION

The IRC 4 Intelligent Relay Card is designed for use in Vibro-Meter's VM 600 series of machinery protection systems and condition and performance monitoring systems. It is an optional card, for use when complex combinations of MPC or AMC internal Discrete Output are required.

The IRC 4 is installed in the rear of the ABE 04X rack and connects directly to the rack backplane via a single connector.

The IRC 4 contains 8 relays with change-over

contacts. Each relay is associated with 3 terminals on a screw terminal strip accessible at the rear of the ABE 04X rack.

No jumper is needed, since every parameters of the IRC 4 is set through software.

The IRC 4 configuration is done using a specific PC GUI - the "IRC4 Configurator".

The GUI uses both files from MPS for the rack environment and Excel file where the equations are described (VM signals list).

BLOCK DIAGRAM

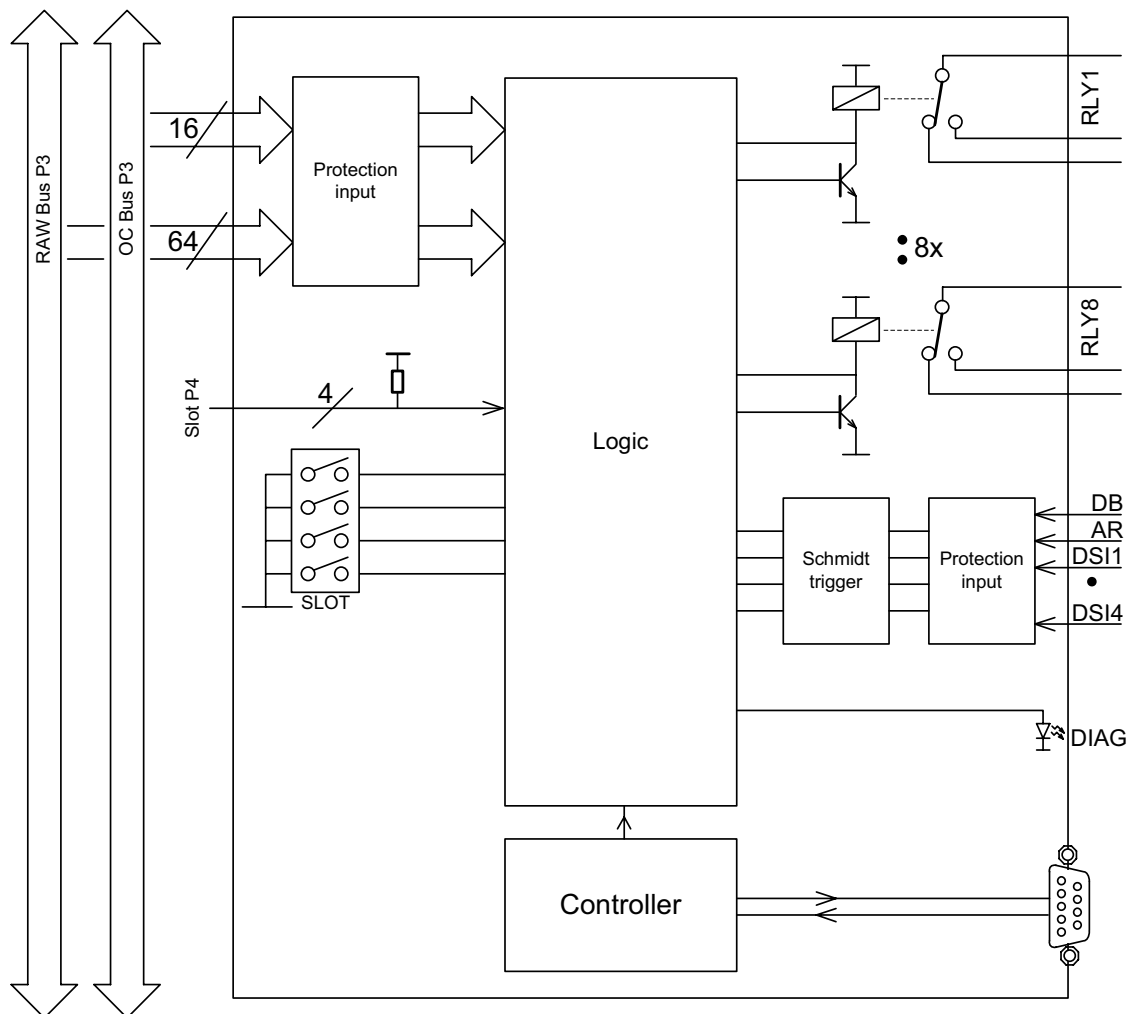

SPECIFICATIONS

RELAY CHARACTERISTICS

Make	: Siemens
Type	: PE014005
Contact arrangement	: 1 x NO / NC contacts per relay (SPDT)
Coil voltage	: 5 VDC
Coil resistance	: 125 Ω \pm 10%
Nominal current	: 0.35 ADC / 5 AAC
Nominal voltage	: 300 VDC / 250 VAC
Max. break power without contact protection	: 100 W (1250 VA)
Pick-up / drop-out / bounce time (contact NO)	: Typically 5 / 2 / 1 ms
Test voltage coil - contact	: 4000 VAC
Test voltage open contact	: 1000 VAC
Mechanical life	: 30 x 10 ⁶ operations
Electrical life	: 10 ⁵ operations

INPUT CHARACTERISTICS

Operating principle	: Detection of open or closed circuit on the input
DANGER BYPASS (DB)	: A closed contact between DB and GND inputs allows operator to inhibit relay outputs
ALARM RESET (AR)	: A closed contact between AR and GND inputs resets latched alarms

DISCRETE INPUTS

Number of inputs	: 64x RAW Bus, 16x OC Bus, 4x General purpose DSI, AR, DB
Input impedance	: Raw Bus and OC Bus \cong 1 M Ω DSI \cong 10 k Ω
Raw Bus & OC Bus Threshold level	: TTL
DSI Threshold level	: Ground = < 3 V Open = < 4.5 V (Pull-up to + 12 V)

ENVIRONMENTAL

Temperature range	
• Operation	: -25°C to +65°C (-13°F to +149°F)
• Storage	: -40°C to +85°C (-40°F to +185°F)
Humidity	
• Operation	: 0 to 90% non-condensing
• Storage	: 0 to 95% non-condensing
Vibration and shock	: See general rack specifications

RELAY PCB ASSEMBLY

Presentation	: 8 relay PCB
Power supply	: +5 VDC / 0.5 A, +12 VDC / 0.01 A
Connections	: Screw terminals
Mounting	: Connects to back plane from rear of rack via a connector

SPECIFICATIONS (Continued)

PHYSICAL

Height	: 6 U (262 mm, 10.31 in)
Width	: 20.1 mm
Depth	: 125 mm
Weight	: 0.3 kg

ORDERING INFORMATION

To order please specify :

Type	Designation	Ordering Number
IRC 4	Relay Card	
	- Standard - No configuration set	620-005-0Ss-1Hh
	- Standard - Specific configuration programmed	601-001-CCC-VVv

Note : "Hh" represents the hardware version. "H" increments for major modifications that can affect product interchangeability. "h" increments for minor modifications that have no effect on interchangeability.
"Ss" represents the FW and Logic version. "S" increments for major modifications that can affect product interchangeability. "s" increments for minor modifications that have no effect on interchangeability.
"VVv" represents the IRC4 version. "V" increments for major modifications that can affect product interchangeability. "v" increments for minor modifications that have no effect on interchangeability.
"CCC" is a specific configuration managed by Vibro-Meter.



All statements, technical information, drawings, performance rates and descriptions in this document, whilst stated in good faith, are issued for the sole purpose of giving an approximate indication of the products described in them, and are not binding on Vibro-Meter SA unless expressly agreed in writing. Before acquiring this product, you must evaluate it and determine if it is suitable for your intended application. Unless otherwise expressly agreed in writing with Vibro-Meter, you assume all risks and liability associated with its use. Any recommendations and advice given without charge, whilst given in good faith, are not binding on Vibro-Meter.

Vibro-Meter takes no responsibility for any statements related to the product which are not contained in a current Vibro-Meter publication, nor for any statements contained in extracts, summaries, translations or any other documents not authored by Vibro-Meter. We reserve the right to alter any part of this publication without prior notice.

In this publication, a dot (.) is used as the decimal separator and thousands are separated by spaces. Example : 12 345.678 90.

Sales offices

Vibro-Meter has offices in more than 30 countries. For a complete list, please visit our website.

Your local agent

Head office

Vibro-Meter SA
Rte de Moncor 4
P.O. Box
CH-1701 Fribourg
Switzerland

Tel: +41 26 407 11 11
Fax: +41 26 407 13 01



www.vibro-meter.com

MEGGITT
smart engineering for
extreme environments