

Hardware Manual

VM600 Condition Monitoring System (CMS)

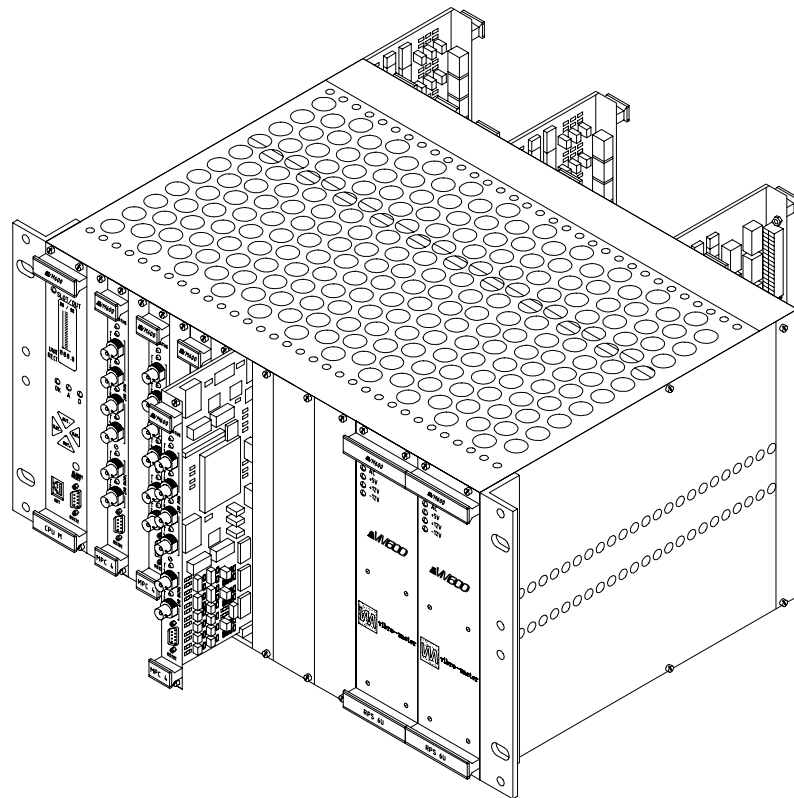

Vibro-Meter SA
Route de Moncor 4
CH - 1701 Fribourg
SWITZERLAND

www.vibro-meter.com

REVISION RECORD SHEET

Edition	Date of Issue	Written by / Modified by	PM No.	Description	Signature
1	20.04.01	R. Meyer	-	Original edition.	
2	28.11.01	R. Meyer		Sections 4.4.4.3 and 4.4.4.4: Correction of settings for SW5_3 (exchange "left" & "right"). Fig. 4-19: SW5_3 set to left now = CJC. Fig. 4-20: FSD on CMC 16 = 4 Vac for the function named "5VAC". Fig. 4-22: SW6 turned anticlockwise by 90°.	
3	31.03.06	N. Parker		Updated for new Corporate Identity	

	Department	Name	Date	Signature
Technical content of original issue approved by	Development	H. Reiss		HR
	Product Management	G. Zurbruggen		GZ
Document released by	Technical Publications	R. Arnaud		RA

The duly signed master copy of this page is stored by the Technical Publications Department of Vibro-Meter S.A. and can be obtained by writing to the Technical Publications Manager.

Copyright © Vibro-Meter SA, 2001-2006

All rights reserved

Published and printed by Vibro-Meter SA in Fribourg, Switzerland

The names of actual companies and products mentioned herein may be the trademarks of their respective owners.

The information contained in this document is subject to change without notice. This information shall not be used, duplicated or disclosed, in whole or in part, without the express written permission of Vibro-Meter.

THIS PAGE INTENTIONALLY LEFT BLANK

TABLE OF CONTENTS

TITLE PAGE	i
REVISION RECORD SHEET	ii
COPYRIGHT	iii
TABLE OF CONTENTS	v
PREFACE	vii
SAFETY	ix
1 INTRODUCTION	1-1
1.1 Application	1-1
1.2 General Overview	1-1
1.2.1 Hardware and Software	1-1
1.2.2 Communicating with the CMS	1-4
1.3 Features	1-6
1.4 Specifications	1-7
2 PHYSICAL PRESENTATION OF CMS HARDWARE	2-1
2.1 19" Rack (ABE 040 / ABE 042)	2-1
2.2 CMC 16 Condition Monitoring Card	2-3
2.3 IOC 16T Input / Output Card	2-3
2.4 CPU M Modular CPU Card	2-6
2.5 IOC N Input / Output Card	2-7
2.6 RPS 6U Rack Power Supply Unit	2-8
2.6.1 Available Versions	2-8
2.6.2 Front Panel LEDs	2-11
2.6.3 Relay to Check Power Supply	2-11
3 INSTALLATION	3-1
3.1 Introduction	3-1
3.2 Attribution of Slots in the Rack	3-1
3.3 Rack Safety Requirements	3-3
3.3.1 Adequate Ventilation	3-3

3.3.2	Circuit Breaker	3-3
3.4	Installation Procedure for Cards	3-5
3.4.1	First-Time Installation of the CMS	3-5
3.4.2	Subsequent Installation of Cards ("Live Insertion" Capability)	3-6
3.4.3	Setting the IP Address of the CPU M Card	3-7
4	ELECTRICAL DESCRIPTION	4-1
4.1	Introduction	4-1
4.2	CMS General Block Diagram	4-1
4.3	VM 600 Backplane	4-3
4.3.1	Overview	4-3
4.3.2	The Tacho Bus	4-6
4.3.3	The Raw Bus	4-8
4.4	Configuration of IOC 16T Cards	4-9
4.4.1	Position of User-Adjustable Elements on the IOC 16T	4-9
4.4.2	Channels 1 to 4 (Tacho, Vibration & Analogue Signals)	4-9
4.4.3	Channels 5 to 16 (Vibration, Analogue & Thermocouple Signals)	4-17
4.4.4	Channel 16	4-22
4.4.5	Elements on the CMC 16	4-29
4.5	Elements on the CMC 16	4-32
4.5.1	CMC 16 Front Panel LED (DIAG)	4-32
4.5.2	DIP Switch Package	4-33
A	ABBREVIATIONS	A-1
PRODUCT DEFECT REPORT		
DOCUMENT EVALUATION FORM		

PREFACE

About This Manual

This manual provides information on the hardware aspects of Vibro-Meter's VM600 series CMS (Condition Monitoring System). It describes the installation, configuration and general use of the system.

Who Should Use This Manual?

This manual is written for operators of process monitoring/control systems using CMS.

The operator is assumed to have the necessary technical training in electronics and mechanical engineering (professional certificate/diploma, or equivalent) to enable him to install, program and use the system.

Related Documentation

Related documents are:

- *VM600 Condition Monitoring System (CMS) Software Manual, Volumes 1 and 2*
Vibro-Meter Document No. MACMS-SW/E
- *VM600 Condition Monitoring System (CMS) Quick Start Manual*
Vibro-Meter Document No. MACMS-QS/E
- *VM600 Networking Manual*
Vibro-Meter Document No. MAVM600-NET/E

THIS PAGE INTENTIONALLY LEFT BLANK

SAFETY

Symbols and Styles Used in This Manual

The following symbols are used in this manual where appropriate :



The WARNING safety symbol

THIS INTRODUCES DIRECTIVES, PROCEDURES OR PRECAUTIONARY MEASURES WHICH MUST BE EXECUTED OR FOLLOWED. FAILURE TO OBEY A WARNING CAN RESULT IN INJURY TO THE OPERATOR OR THIRD PARTIES.



The CAUTION safety symbol

This draws the operator's attention to information, directives or procedures which must be executed or followed. Failure to obey a caution can result in damage to equipment.



The ELECTROSTATIC SENSITIVE DEVICE symbol

This indicates that the device or system being handled can be damaged by electrostatic discharges.

Refer to Handling Precautions for Electrostatic Sensitive Devices on page xii for further information.

NOTE : This is an example of the NOTE paragraph style. This draws the operator's attention to complementary information or advice relating to the subject being treated.

Important Remarks on Safety



Read this manual carefully and observe the safety instructions before using the equipment described.

Location of Safety Symbols

The following safety symbols are found on the pages specified below :



THIS SYMBOL IS FOUND ON THE FOLLOWING PAGES:



This symbol is found on the following pages:



This symbol is found on the following page:

Additional Remarks

Every effort has been made to include specific safety-related procedures in this manual using the symbols described above. However, operating personnel are expected to follow all generally accepted safety procedures.

Safety procedures should be communicated to all personnel who are liable to operate the equipment described in this manual.

Vibro-Meter does not accept any liability for injury or material damage caused by failure to obey any safety-related instructions or due to any modification, transformation or repair carried out on the equipment without written permission from Vibro-Meter. Any modification, transformation or repair carried out on the equipment without written permission from Vibro-Meter will invalidate any warranty.

Equipment Used in Potentially Explosive Atmospheres



THIS MANUAL COVERS EQUIPMENT THAT CAN BE USED IN POTENTIALLY EXPLOSIVE ATMOSPHERES, AS WELL AS EQUIPMENT THAT CANNOT BE USED IN POTENTIALLY EXPLOSIVE ATMOSPHERES.

TO ENSURE THAT THE EQUIPMENT CAN SAFELY BE USED IN POTENTIALLY EXPLOSIVE ATMOSPHERES, IT IS ESSENTIAL TO:

- VERIFY IT IS IDENTIFIED WITH SPECIAL MARKING DESCRIBED IN THE “EC TYPE EXAMINATION CERTIFICATE” FOR THE PRODUCT,
- RESPECT THE CRITERIA MENTIONED IN THE SAME “EC TYPE EXAMINATION CERTIFICATE”.

AN “X” OR A “U” PLACED AFTER THE CERTIFICATE NUMBER INDICATES THAT THE EQUIPMENT IS SUBJECT TO SPECIAL CONDITIONS FOR SAFE USE. THESE CONDITIONS ARE MENTIONED IN THE “SCHEDULE” SECTION OF THE CERTIFICATE.

REFER TO THE SAFETY MANUAL MENTIONED IN PREFACE (PAGE VII OF THIS MANUAL) FOR FURTHER INFORMATION.

General Handling Precautions

Vibro-Meter’s transducers are rugged devices which can withstand a certain amount of careless handling. Nevertheless, certain precautions should be taken when handling.



Read the following recommendations carefully before handling transducers.

- Do not drop the transducer onto a hard surface or subject it to violent shocks.
- Protect the body/head of the transducer with plastic protective netting when it is being handled, stored or transported. Remove this protection only when mounting the transducer or when inspecting/testing it.
- Check for dents when inspecting the transducer as this is a sign that it could have suffered a physical shock by impact. This may have caused damage to components within the transducer.
- Do not excessively bend the transducer cable or associated cables. Respect the minimum bending radius quoted in the appropriate data sheet.
- When storing and using the equipment, respect the environmental specifications (temperature, humidity) quoted in the appropriate data sheet.
- Refer also to section Handling Precautions for Electrostatic Sensitive Devices on page xii.

Handling Precautions for Electrostatic Sensitive Devices

Certain devices used in electronic equipment can be damaged by electrostatic discharges resulting from built-up static electricity. Because of this, special precautions must be taken to minimize or eliminate the possibility of these electrostatic discharges occurring.



Read the following recommendations carefully before handling electronic circuits, printed circuit boards or modules containing electronic components.

- Before handling electronic circuits, discharge the static electricity from your body by touching and momentarily holding a grounded metal object (e.g. a pipe or cabinet).
- Avoid the build-up of static electricity on your body by not wearing synthetic clothing material, as these tend to generate and store static electric charges. Cotton or cotton blend materials are preferred because they do not store static electric charges.
- Do not handle electronic circuits unless it is absolutely necessary. Only hold modules by their front panel handles.
- Do not touch printed circuit boards, their connectors or their components with conductive devices or with your hands.
- Put the electronic circuit, printed circuit board or module containing electronic components into an antistatic protective bag immediately after removing it from the system rack.

1 INTRODUCTION

1.1 Application

CMS is a digital Condition Monitoring System designed for use in industrial applications. It is intended principally for monitoring the condition of rotating machinery used in, for example, the power generation, petro-chemical and petroleum industries as well as in marine-related applications.

1.2 General Overview

1.2.1 Hardware and Software

The CMS belongs to Vibro-Meter's VM600 series of Machinery Protection and Monitoring Systems. It is a modular system consisting of cards that fit into a common rack assembly (19" x 6 U). Two types of 19" x 6U rack exist: the ABE 040 and the ABE 042. These are identical except for the position of the rack mounting brackets.

In its most basic configuration the ABE 04X rack houses the following types of CMS hardware:

- CMC 16 Condition monitoring card
- IOC 16T Input/output card (matching the CMC 16)
- RPS 6U Rack power supply unit

The CMC 16 and IOC 16T cards form an inseparable pair and one cannot be used without the other.

A networked version of the CMS will in addition contain the following hardware in the ABE 04X rack:

- CPU M Modular CPU card
- IOC N Input/output card (matching the CPU M)

A combined machinery protection system (MPS) and condition monitoring system (CMS) can in addition contain the following hardware in the ABE 04X rack:

- MPC 4 Machinery protection card
- IOC 4T Input/output card (matching the MPC 4)
- RLC 16 Relay card

Figure 1-1 and Figure 1-2 show front and rear views of a typical rack featuring MPS and CMS hardware.

NOTE : Refer to the *VM 600 Series MPS1 Software Instruction Manual* (Doc. No. 665.040) for further information on the MPC 4, IOC 4T and RLC 16 cards, and their use in a machinery protection system.

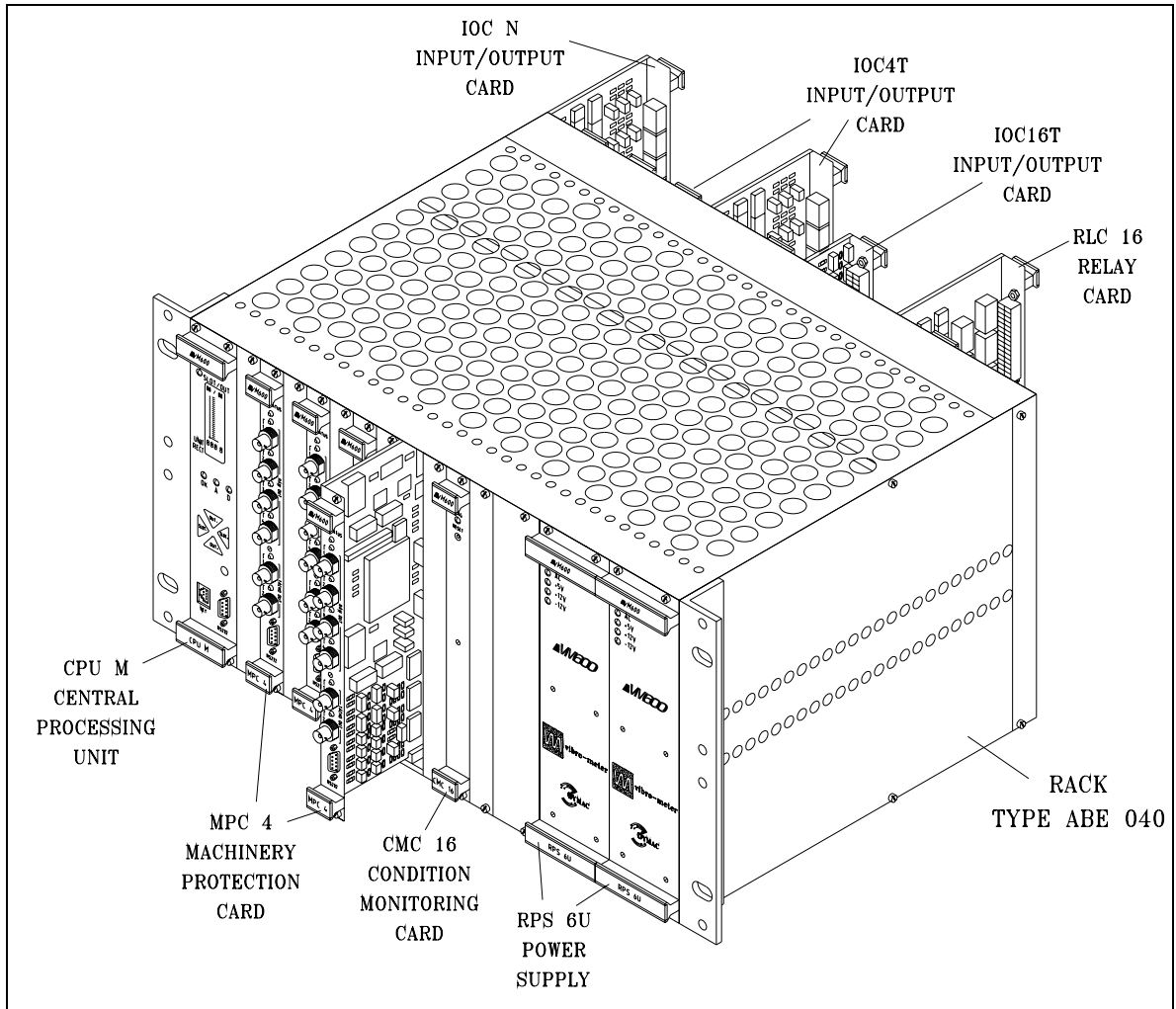

Figure 1-1 : Front view schematic of a VM 600 Series CMS within a 19" x 6U ABE 04X rack (The rack shown also contains MPC 4, RLC 16 and IOC 4T cards for machinery protection purposes)

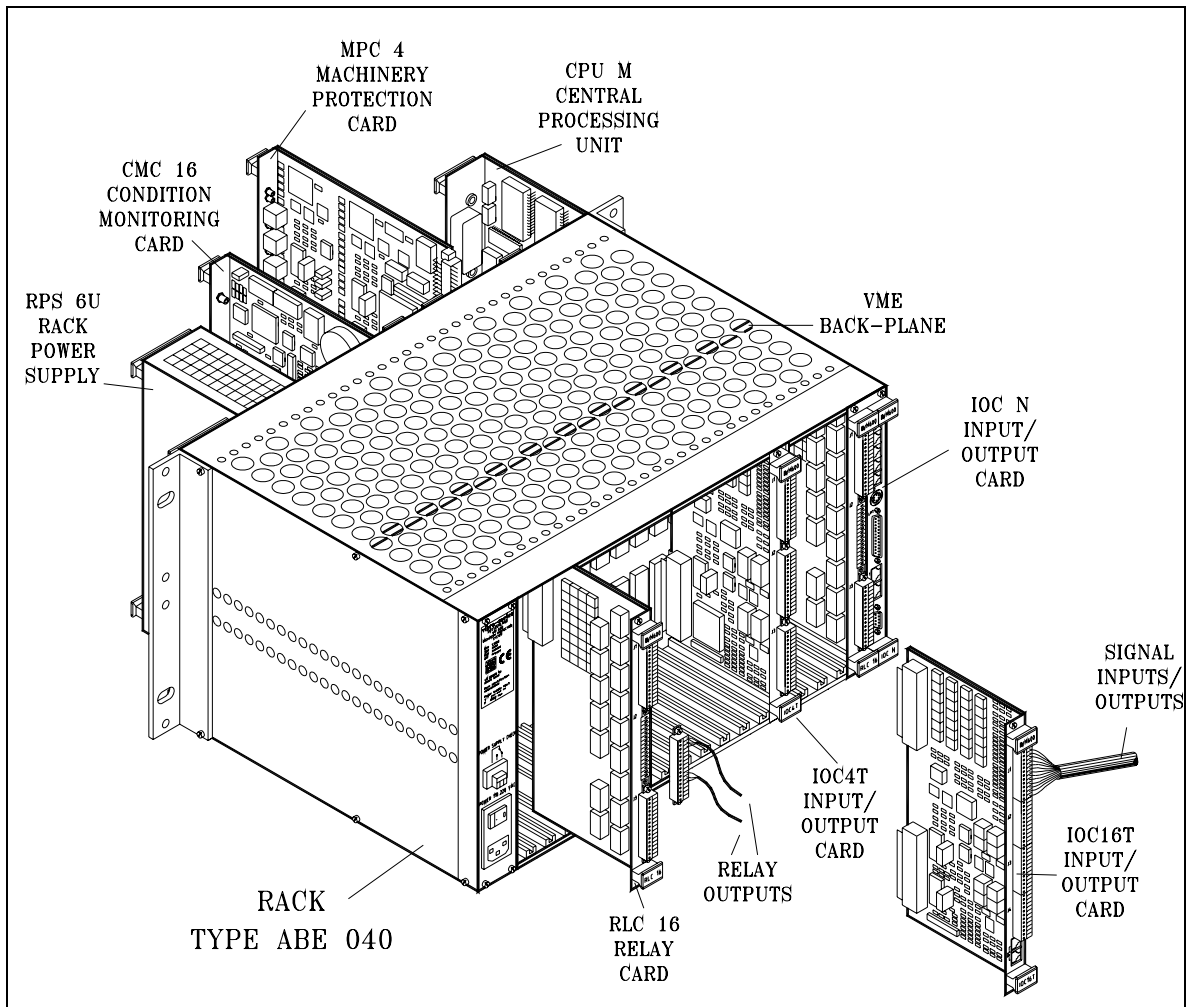

Figure 1-2 : Rear view schematic of a VM 600 Series CMS within a 19" x 6U ABE 04X rack (The rack shown also contains MPC 4, RLC 16 and IOC 4T cards for machinery protection purposes)

The following software package is required to configure the CMS:

- VM600 CMS Software

This software runs on a personal computer or server having Windows 98, Windows NT, or Windows XP installed.

NOTE : Refer to the *VM600 CMS Software Manual* for further information.

1.2.2 Communicating with the CMS

The CMS may be configured in several ways, depending on the hardware installed in the ABE 04X rack. Figure 1-3 shows the various possibilities for communicating with the system.

Figure 1-3 (a) shows the simplest configuration. A personal computer communicates over an RS-485 multi-drop link to all IOC 16T / CMC 16 pairs in the rack. The IOC 16T cards are daisy-chained together at the back of the rack.

Figure 1-3 (b) shows a rack containing a modular CPU card (type CPU M). An Ethernet link may be established between the personal computer and the CMS via this card. The connection is made on the front panel of the CPU M, hence at the front of the rack. Communication between the CPU M and the IOC 16T / CMC 16 pair takes place over a VME bus on the rack backplane.

Figure 1-3 (c) shows a rack containing a modular CPU card (type CPU M) and the matching IOC N input / output card. An Ethernet link may be established between the personal computer and the CMS via the IOC N. The connection is made on the IOC N panel, hence at the rear of the rack. Communication between the IOC N/CPU M pair and the IOC 16T/CMC 16 pair takes place over a VME bus on the rack backplane.

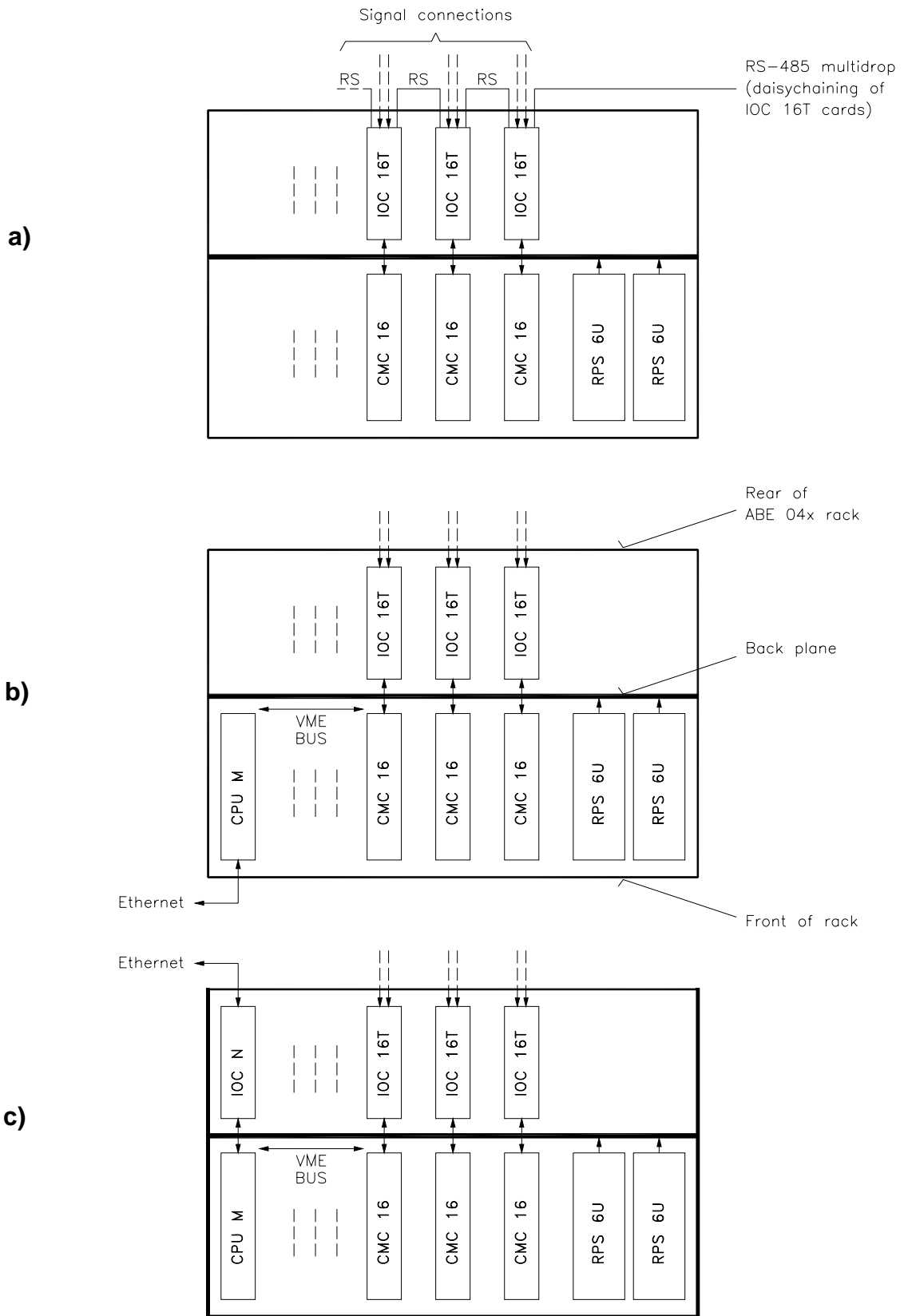

Figure 1-3 : Methods of Communicating with the CMS

1.3 Features

The CMS is based around the CMC 16 / IOC 16T pair of cards. The main features of this combination of cards are listed below:

- 16 individually configurable channels. All 16 channels can be used for “vibration” signals (i.e. dynamic signals representing vibration, dynamic pressure or any other rapidly-changing parameter). All channels can also all be used for “analogue” signals (i.e. slowly-varying, quasi-static or DC signals representing temperature, static pressure, flow rate, fluid level, position, etc.).
- Channels 1 to 4 can additionally be used for processing tacho signals.
- Channels 5 to 16 can additionally be used for processing thermocouple signals.
- Channel 16 can additionally be used to connect a temperature sensor (type AD590). This allows cold junction compensation for thermocouples connected to Channels 5 to 15.
- Signal conditioning provided by the IOC 16T for all inputs.
- Configurable synchronous and asynchronous sampling.
- Various operating modes available: Background, Transient, Scheduled, Real-Time and Oscilloscope
- High-resolution 3200-line Fast Fourier Transform (FFT) analysis.
- Vibration background logging based on 400-line spectra.
- Processing and analysis of up to 10 fully-configurable frequency bands per dynamic channel.
- 6 configurable alarms thresholds per band (Low/High Alert, Low/High Alarm and Low/High Validation). A hysteresis deadband may be attributed to each threshold.
- Historic and transient trending of bands.
- Spectrum trending (transient cascades).
- Simultaneous sampling possible for channels having the same tacho and bandwidth.
- Programmable anti-aliasing filters and ADCs for each of the 16 channels (on CMC 16).
- Host communication via the VME bus on rack backplane to a CPU M card in Slot 0, with subsequent Ethernet link, or Communication via direct multi-drop RS-485 serial link to connectors on the IOC 16T.
- Screw terminal strip (48 terminals) on IOC 16T for connection of signal transmission lines coming from external measuring systems.
- Live insertion / removal (“hot swapping”) of CMC 16 and IOC 16T cards.
- Protection against electromagnetic interference (EMI) provided by the IOC 16T for all inputs and outputs.
- Meets electromagnetic compatibility (EMC) standards.

Refer to the corresponding chapters for further information.

1.4 Specifications

For full technical specifications of the elements used in the CMS, refer to the corresponding data sheets available from Vibro-Meter:

Data Sheet		Document No.
<i>ABE 040 & ABE 042</i>	<i>19" Rack</i>	268-001 E
<i>CMC 16</i>	<i>Condition monitoring card</i>	268-051 E
<i>CPU M & IOC N</i>	<i>Modular CPU card & Input / output card</i>	268-031 E
<i>IOC 16T</i>	<i>Input/output card</i>	268-074 E
<i>RPS 6U</i>	<i>Rack power supply unit</i>	268 011 E

THIS PAGE INTENTIONALLY LEFT BLANK

2 PHYSICAL PRESENTATION OF CMS HARDWARE

This chapter provides a brief overview of the physical appearance of the condition monitoring system (CMS) hardware. Functional information is also given for certain elements (push buttons, LEDs, etc.) found on the front / rear panels.

NOTE : Further information on specific elements can be found in the corresponding data sheets.

2.1 19" Rack (ABE 040 / ABE 042)

The CMS is housed in a 19-inch rack (84TE) having a height of 6U (6HE). Two rack types exist: the ABE 040 and the ABE 042. These are identical, except for the position of the rack mounting brackets. An example of a CMS housed in an ABE 040 rack is shown in Figure 2-1.

The ABE 04X contains a front and a rear card cage. The card cages are separated by the rack backplane.

The appearance of the front and rear panels of the rack depends entirely on the types of cards installed in the two card cages. These cards are presented in the following sections of this chapter.

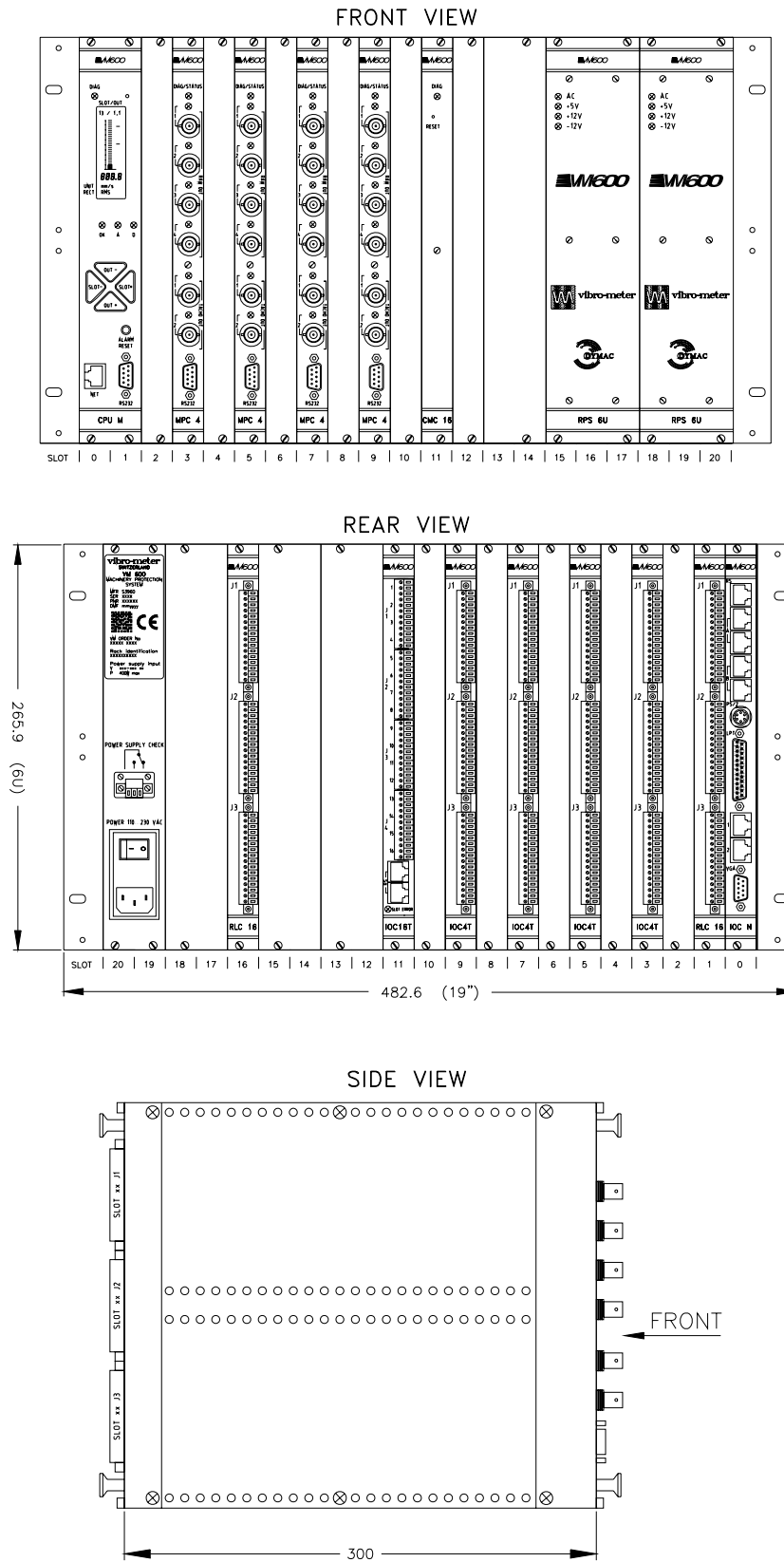

Figure 2-1 : Views of a typical ABE 040 rack with several cards installed

2.2 CMC 16 Condition Monitoring Card

Figure 2-2 (a) shows a view of the CMC 16 front panel. A side view of this panel is shown in Figure 2-2 (b). The panel contains the following elements:

- 1- DIAG (Diagnostic) LED indicator
- 2- RESET button Pushing the RESET button generates a hardware reset that erases the whole RAM memory.

NOTE : Refer to Chapter 4 - Electrical Description for a full description of the operation of the LED.

2.3 IOC 16T Input / Output Card

The IOC 16T panel (found on the rear of the ABE 04X rack) contains 4 terminal strips, identified as J1, J2, J3 and J4 (see Figure 2-3). Each strip consists of a socket and a mating connector, which contains 12 screw terminals. The screw terminals can accept wires with a cross section of 1.5 mm². The socket and mating connector can be equipped with a mechanical key system to prevent incorrect connection.

The panel also contains two RJ11 connectors (denominated RS) to allow RS-485 multi-drop communication between a host PC and the IOC 16T cards in the rack.

The SLOT ERROR LED indicates if the IOC 16T card has been installed in the correct slot of the rack. The LED is green when the card is inserted in the correct slot, and is red when it is inserted in an incorrect slot.

Figure 2-3 (a) shows the appearance of the IOC 16T panel without the 4 mating connectors. In this configuration, the engraving showing the terminal definitions is clearly seen. Figure 2-3 (b) shows the appearance of the panel when the 4 mating connectors are inserted. Figure 2-3 (c) shows a side view of the IOC 4T panel with the mating connectors inserted.

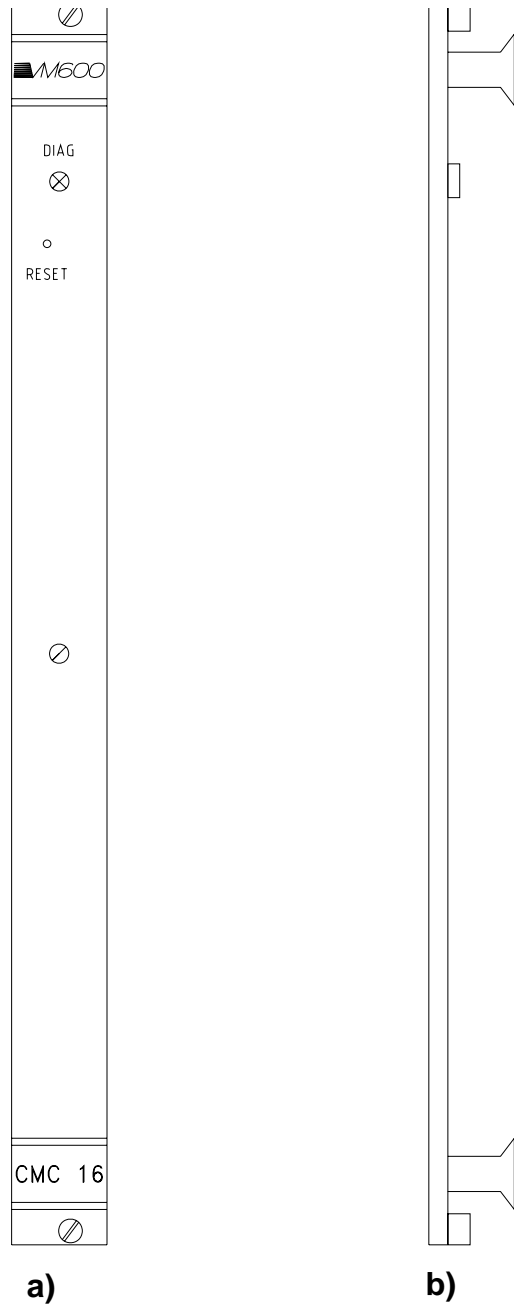

Figure 2-2 : Front panel of the CMC16

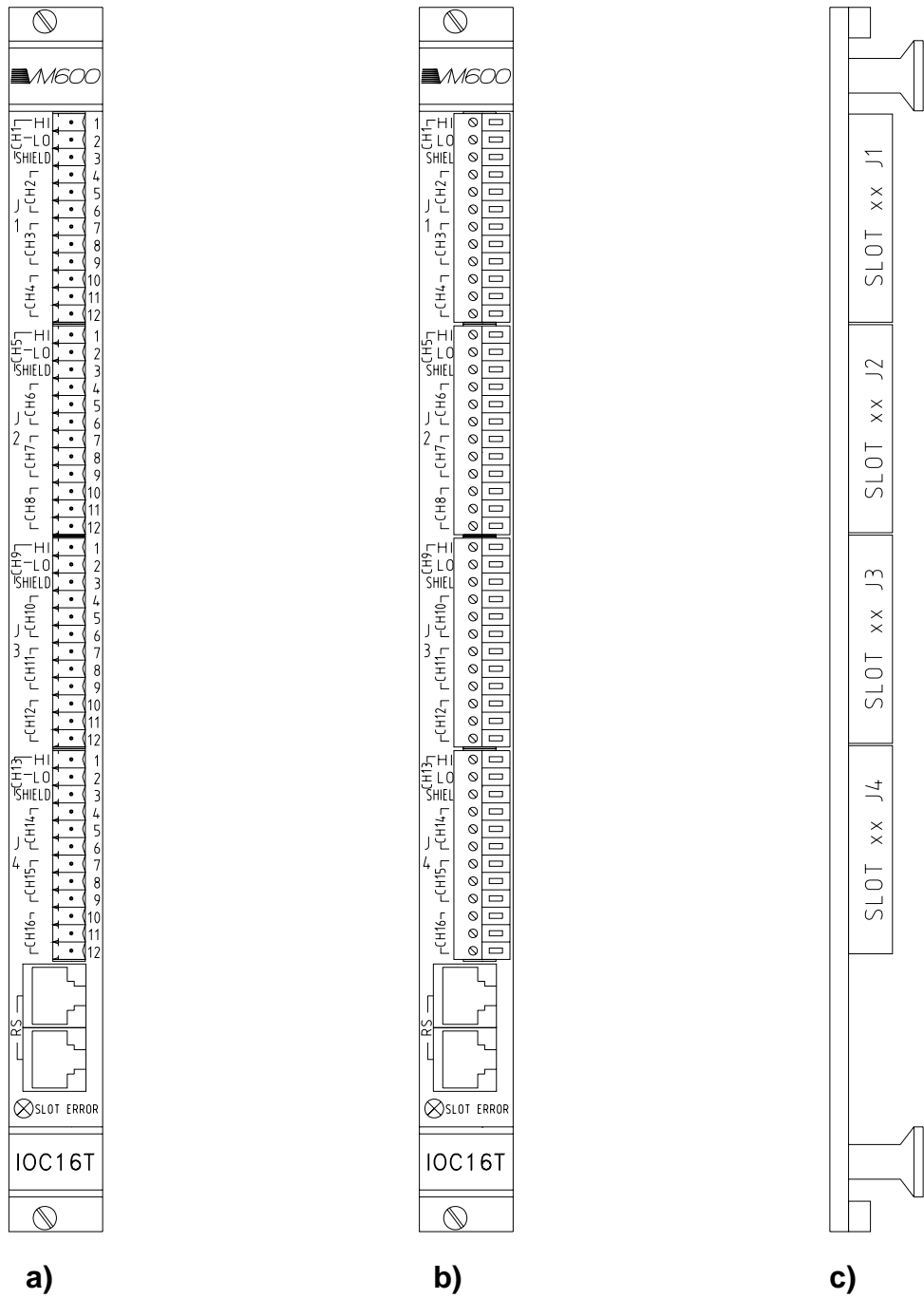

Figure 2-3 : The IOC 16T panel (on rear of the ABE 04X rack)

2.4 CPU M Modular CPU Card

The CPU M is an optional card in the CMS rack. Figure 2-4(a) shows a view of the CPU M front panel. A side view of this panel is shown in Figure 2-4(b).

NOTE : Refer to the CPU M & IOC N data sheet for further information on the elements on the CPU M front panel.

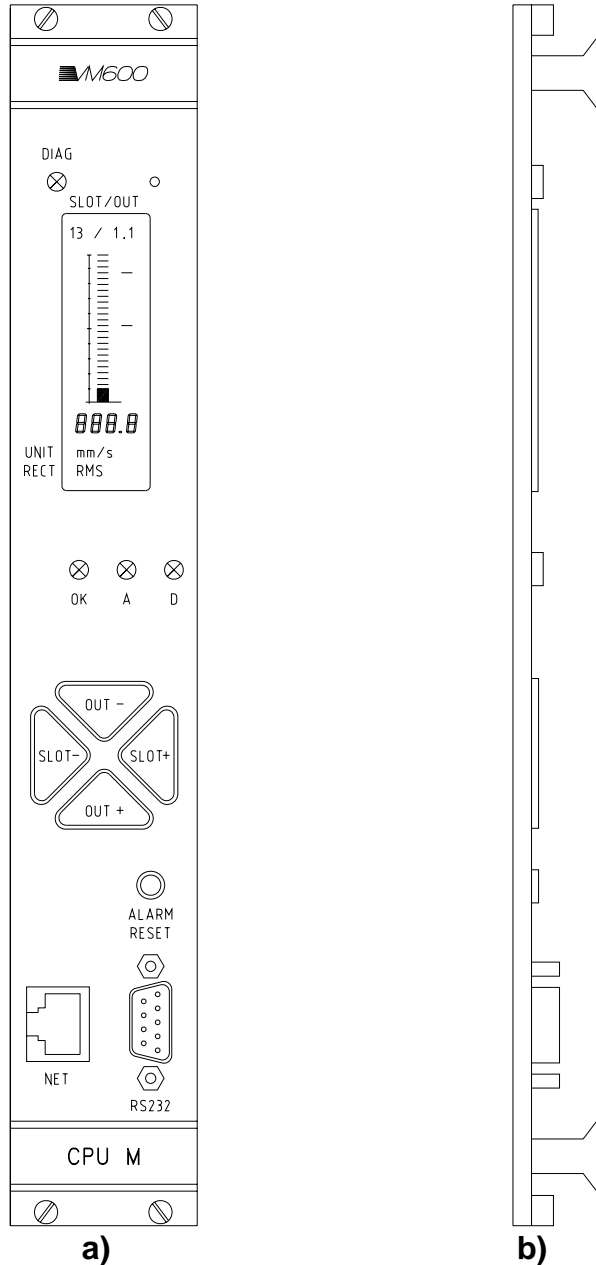

Figure 2-4 : The CPU M Front Panel

2.5 IOC N Input / Output Card

The IOC N is an optional card in the CMS rack. Figure 2-5(a) shows a view of the IOC N panel. A side view of this panel is shown in Figure 2-5(b).

NOTE : Refer to the CPU M & IOC N data sheet for further information on the elements on the IOC N panel.

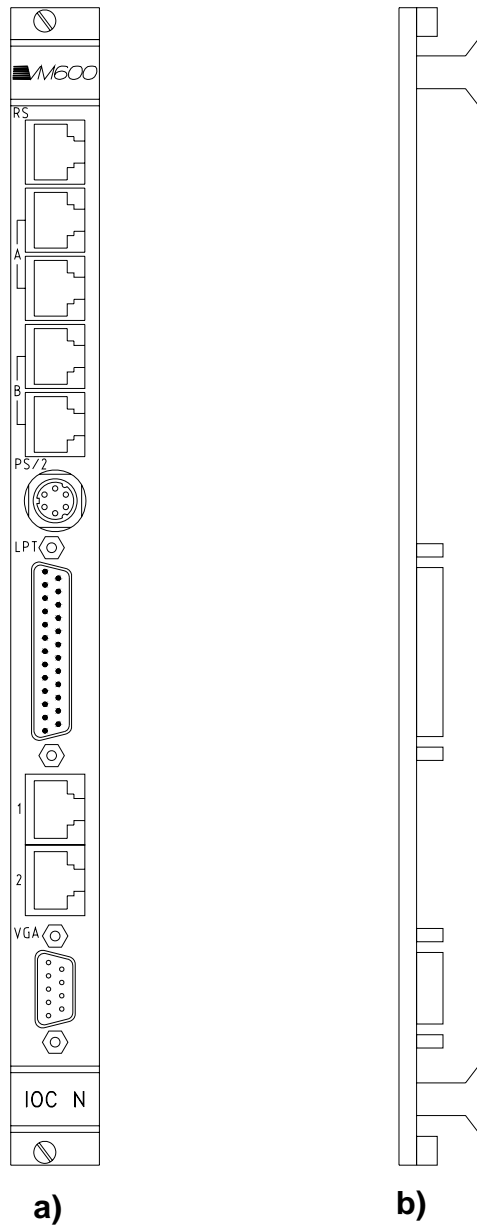

Figure 2-5 : The IOC N panel (on rear of the ABE 04X rack)

2.6 RPS 6U Rack Power Supply Unit

2.6.1 Available Versions

The following versions of the RPS 6U unit are available:

- An RPS 6U unit intended for use with an AC mains supply and having an associated rear panel with an AC mains socket (see Figure 2-6)
- An RPS 6U unit intended for use with a DC mains supply and having an associated rear panel with a DC mains socket (see Figure 2-7 and Figure 2-8)

One or two RPS 6U units may be present in a rack. If two are present, one of the units is “redundant”.

These units are distinguished by their ordering number (refer to the RPS 6U data sheet).

Figure 2-6 shows:

- The front panel of the AC version of the RPS 6U rack power supply unit.
- The associated rear panel found at the rear of the ABE 04X rack.
- A side view of this rear panel.

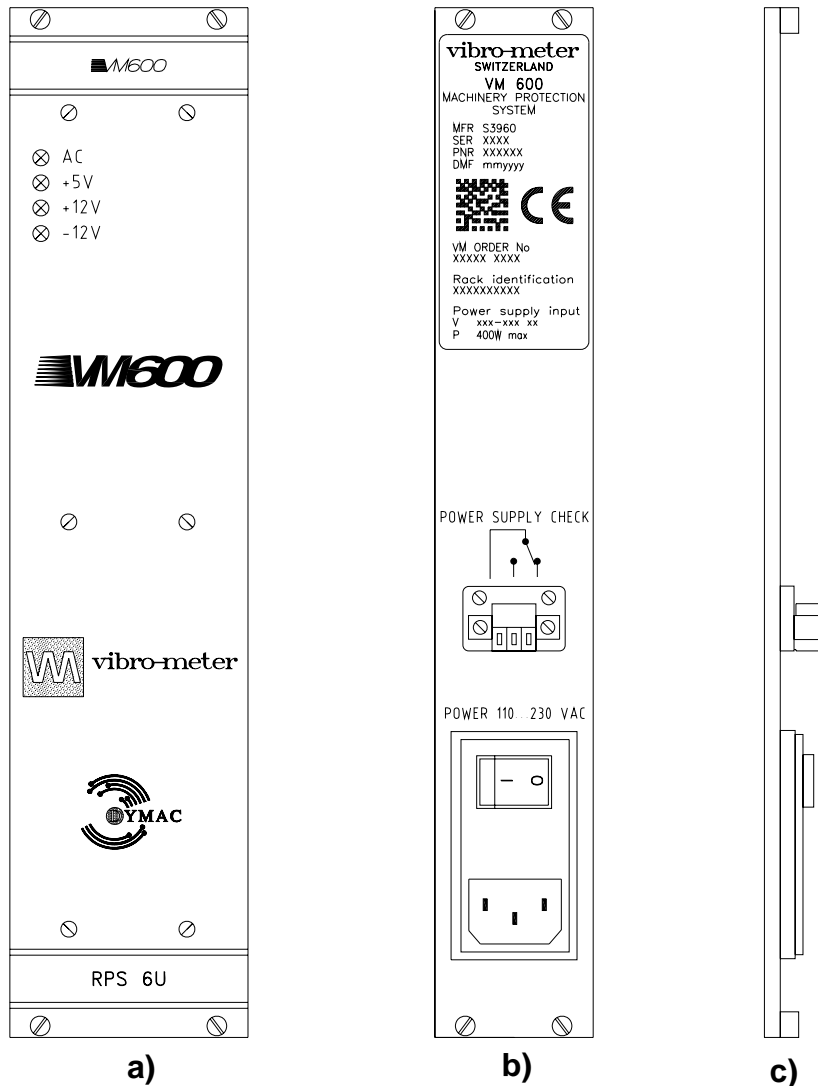

Figure 2-6 : The RPS 6U rack power supply unit intended for use with an AC mains supply

Figure 2-7 shows:

- a) The front panel of the DC version of the RPS 6U rack power supply unit.
- b) The associated rear panel found at the rear of the ABE 04X rack.
- c) A side view of this rear panel.

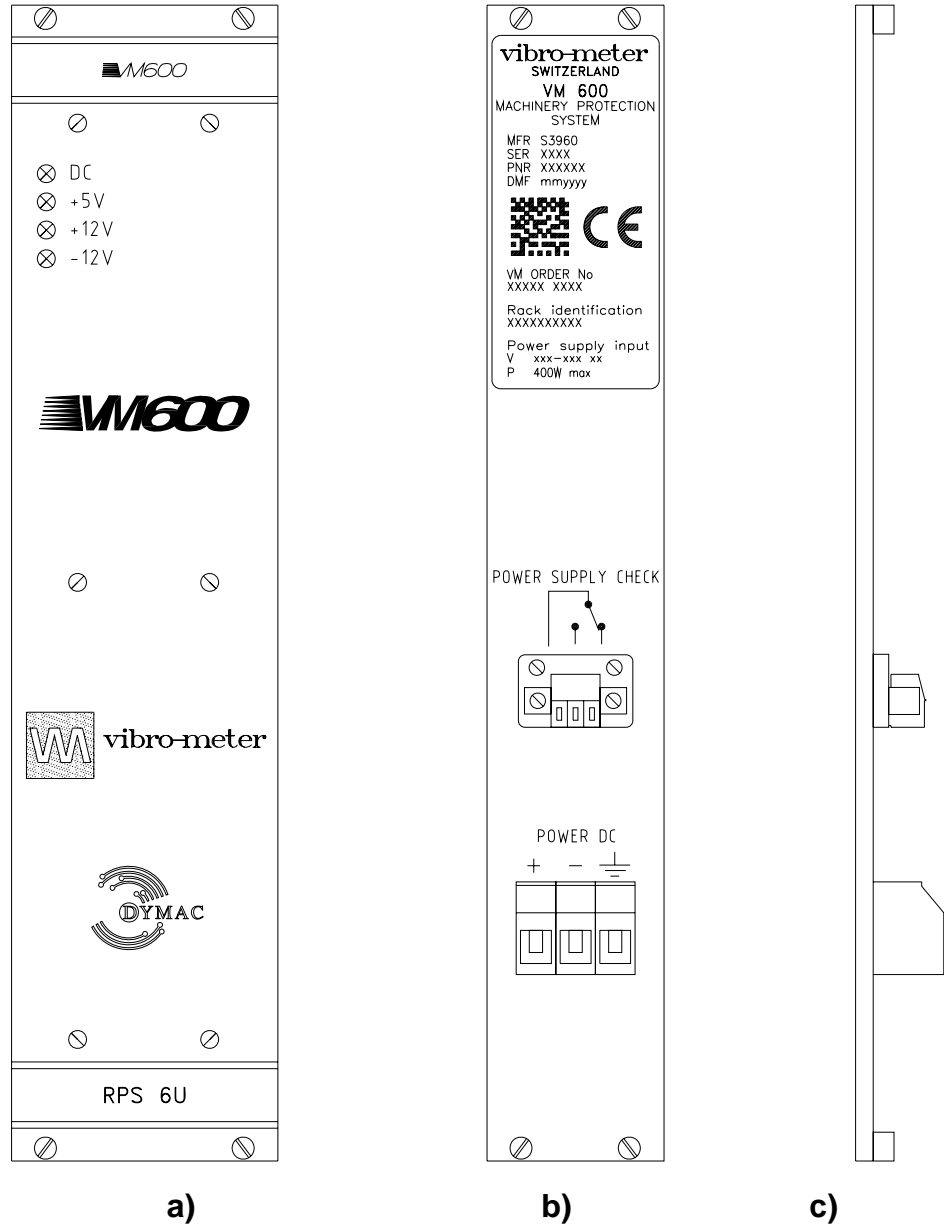

Figure 2-7 : The RPS 6U rack power supply unit intended for use with a DC mains supply (showing standard version of associated rear panel)

Figure 2-7 shows the standard version of the associated rear panel.

An alternative option having two independent DC sockets is shown in Figure 2-8. This can be used with racks having a single RPS 6U unit or racks having two RPS 6U units (one of them being “redundant”).

Figure 2-8 shows:

- a) The (standard) front panel of the DC version.
- b) The optional associated rear panel found at the rear of the ABE04X rack.
This panel allows the connection of two independent DC mains supplies.
- c) A side view of this optional rear panel.

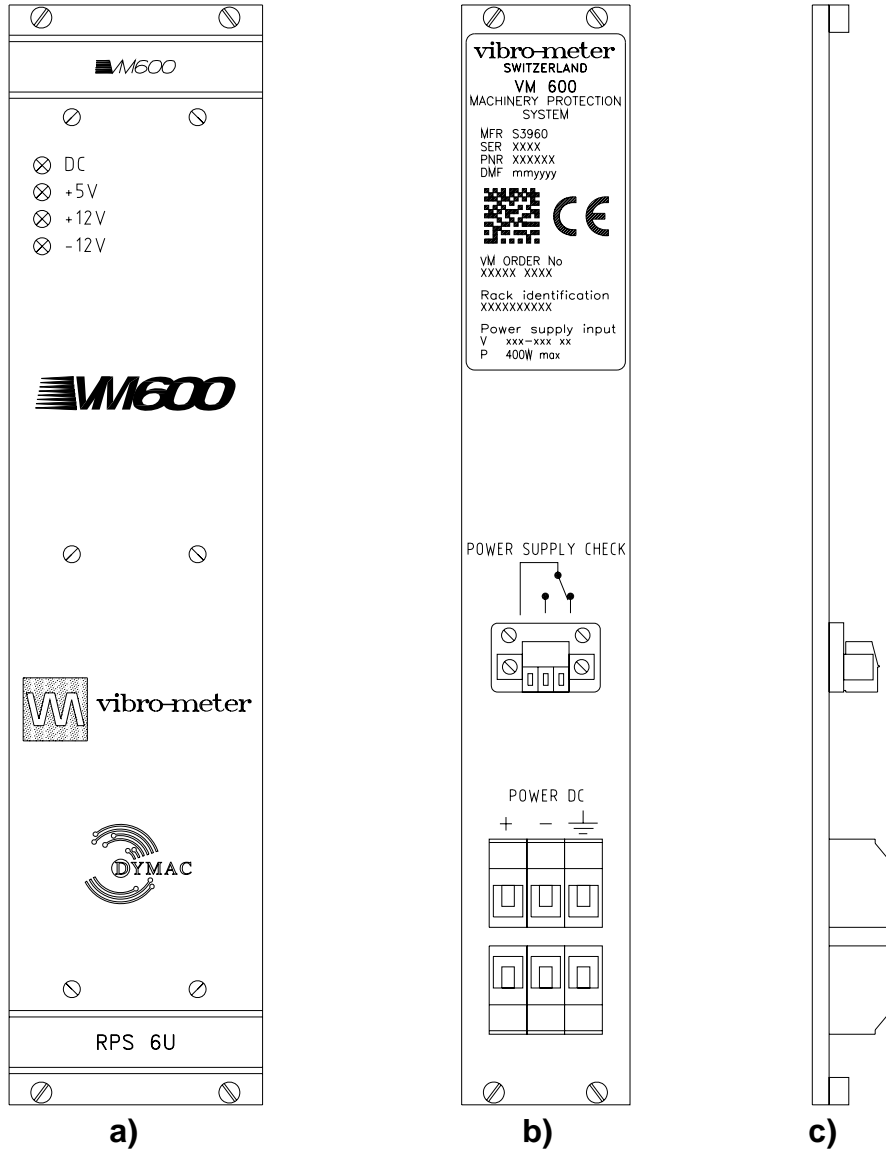

Figure 2-8 : The RPS 6U rack power supply unit intended for use with two independent DC mains supplies

Both sockets on the rear panel are connected to the same points on the rack backplane, as shown in Figure 2-9. The diodes on the DC+ lines protect one supply if the other one fails.

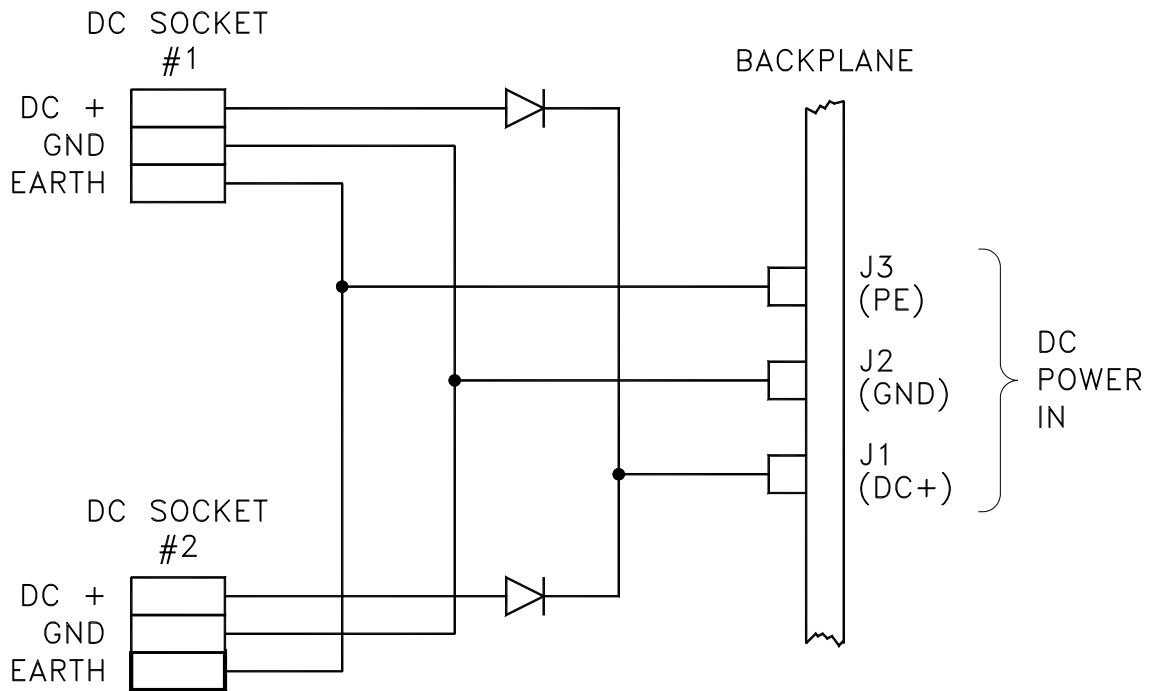

Figure 2-9 : Wiring between the two DC mains sockets and the rack backplane

2.6.2 Front Panel LEDs

In all versions of the RPS 6U, the +5V, +12V and -12V LEDs are yellow and are all lit when the unit is functioning correctly. If a problem exists with one of these derived voltages, the corresponding LED indicator will be off.

The mains supply indicator (named “AC” or ”DC”) is green and is lit when the mains supply is connected.

2.6.3 Relay to Check Power Supply

The POWER SUPPLY CHECK relay on the rear panel may be used to check the +5 V supply delivered by the RPS unit(s) to the backplane. The relay has 3 terminals, numbered 1, 2 and 3 from left to right, as shown in Figure 2-10 below. The behaviour depends on whether one or two RPS units are present.

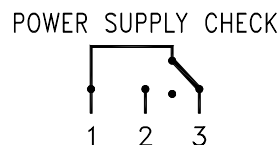

Figure 2-10 : The POWER SUPPLY CHECK relay

When one RPS unit is present:

- Supply OK: All contacts open circuit
- Supply not OK: Contacts 1 3 closed
- Power off: Contacts 1 3 closed

Note the relay behaves in “normally energized” (NE) mode.

When two RPS units (in a “redundant” configuration) are present:

- Supply OK: Contacts 12 closed
- 1 out of 2 RPS units defective: All contacts open-circuit
- 2 out of 2 RPS units defective: Contacts 1-3 closed
- Power off: Contacts 1 3 closed

Note the relay behaves in “normally energized” (NE) mode.

3 INSTALLATION

3.1 Introduction

The CMS is a modular system with cards being installed in a 19" x 6U rack (type ABE 040 or ABE 042). This rack has 21 VME slots, designated Slot 0 to Slot 20 (from left to right, as seen from the front).

The front and rear card cages of the rack are partitioned by a back plane. Each side of the back plane is equipped with connectors allowing modules and cards to be quickly and easily installed.

The following elements are connected to the back plane by installing them from the front of the rack:

- CMC 16 Condition monitoring card
- CPU M Modular CPU card (optional)
- RPS 6U Mains power supply unit

The following elements are connected to the back plane by installing them from the rear of the rack:

- IOC 16T Input/output card
- IOC N Input/output card for CPU M (optional)

If the ABE 04X is intended for use as a machinery protection system (MPS) as well as a condition monitoring system (CMS) it may also have some or all of the following elements in it:

- MPC 4 Machinery protection card
 Installed in front card cage.
- IOC 4T Input/output card (matching MPC 4)
 Installed in rear card cage.
- RLC 16 Relay card
 Installed in rear card cage.

3.2 Attribution of Slots in the Rack

The following installation restrictions apply:

VME Slot No.	Unit / card accepted in front card cage	Card accepted in rear card cage
0	CPU M	IOC N (matching CPU M)
1	Inserted in Slot 0	RLC 16 - Note (3)
2	(Width of unit = 3 slots)	RLC 16 - Note (3)
3	CMC 16 (MPC 4) Note (1)	IOC 16T (IOC 4T or RLC 16) - Note (2)
4	CMC 16 (MPC 4) Note (1)	IOC 16T (IOC 4T or RLC 16) - Note (2)

Figure 3-1 : Attribution of Slots in the Rack (Part 1 of 2)

VME Slot No.	Unit / card accepted in front card cage	Card accepted in rear card cage
5	CMC 16 (MPC 4) Note (1)	IOC 16T (IOC 4T or RLC 16) - Note (2)
6	CMC 16 (MPC 4) Note (1)	IOC 16T (IOC 4T or RLC 16) - Note (2)
7	CMC 16 (MPC 4) Note (1)	IOC 16T (IOC 4T or RLC 16) - Note (2)
8	CMC 16 (MPC 4) Note (1)	IOC 16T (IOC 4T or RLC 16) - Note (2)
9	CMC 16 (MPC 4) Note (1)	IOC 16T (IOC 4T or RLC 16) - Note (2)
10	CMC 16 (MPC 4) Note (1)	IOC 16T (IOC 4T or RLC 16) - Note (2)
11	CMC 16 (MPC 4) Note (1)	IOC 16T (IOC 4T or RLC 16) - Note (2)
12	CMC 16 (MPC 4) Note (1)	IOC 16T (IOC 4T or RLC 16) - Note (2)
13	CMC 16 (MPC 4) Note (1)	IOC 16T (IOC 4T or RLC 16) - Note (2)
14	CMC 16 (MPC 4) Note (1)	IOC 16T (IOC 4T or RLC 16) - Note (2)
15	RPS 6U unit - Note (4)	RLC 16 - Note (3)
16	Inserted in Slot 15	RLC 16 - Note (3)
17	(Width of unit = 3 slots)	RLC 16 - Note (3)
18	RPS 6U unit	RLC 16 - Note (3)
19	Inserted in Slot 18	Back plate of RPS 6U unit(s)
20	(Width of unit = 3 slots)	

Figure 3-1 : Attribution of Slots in the Rack (Part 2 of 2)

Notes relating to Table 3-1:

- (1) In a system intended purely for condition monitoring, Slots 3 to 14 contain only CMC 16 cards. MPC 4 cards may be installed in any of these slots if additional machinery protection capability is required.
- (2) When a CMC 16 card is installed in a given slot, an IOC 16T card must be installed in the slot directly behind it. When an MPC 4 card is installed in a given slot, an IOC 4T card must be installed in the slot directly behind it (an RLC 16 cannot be installed).
- (3) Only RLC 16 cards may be installed in these slots. This is only possible for racks with machinery protection capability (i.e. racks containing MPC 4 / IOC 4T cards).
- (4) Normally only one RPS 6U will be installed (occupying Slots 15 to 17). A second unit may be installed in systems requiring a “redundant” power supply (this will occupy Slots 18 to 20).

3.3 Rack Safety Requirements

3.3.1 Adequate Ventilation

The 19" x 6U racks (types ABE 040 and ABE 042) do not contain any ventilation units (fans). They therefore rely on either forced ventilation by fans in the cabinet or on natural ventilation (convection) for their cooling. Both require the free flow of air in an upward direction, with the air entering the rack through the vents in the base of the rack and leaving it through the vents on the top of the rack.

When racks are installed in a cabinet or enclosure in which natural ventilation is used, a space of at least 50 mm should be present below and above each rack (see Figure 3-2(a)).



Always ensure adequate spacing (minimum 50 mm) is provided below and above the rack to allow proper natural ventilation.

The rack will overheat if this is not done. This will affect the correct operation of the system.

It is possible to prevent warm air flowing from one rack to another by placing inclined plates between them (see Figure 3-2(b)). A space of 50 mm should be present below and above each rack.

If a rack is assembled without empty slots between the processing cards (MPC or CMC), it is recommended to use forced ventilation if the temperature of the air flowing through the rack exceeds 40° C. If the rack has at least one empty slot between each processing card, it is recommended to use forced ventilation if the temperature of the air flowing through the rack exceeds 55° C.

In a case where forced ventilation by fan units is used, the spacing above, below and between racks may be reduced to zero, providing that the air flow to/from neighbouring racks is ensured.

3.3.2 Circuit Breaker

In some circumstances the operator must ensure a switch or circuit breaker is provided in order to comply with the IEC 1010 standard. This standard stipulates that permanently connected equipment (such as an ABE 04X rack) must employ a switch or circuit breaker as a means of disconnection from the mains supply.

ABE 04X racks employing an AC version of the RPS 6U power supply already have an ON/OFF switch at the back of the rack. However, this is not the case for the DC versions of the RPS6U.



If the ABE 04X rack employs a DC version of the RPS 6U power supply, you must ensure that the power cable linking the rack to the mains supply passes through a switch or circuit breaker.

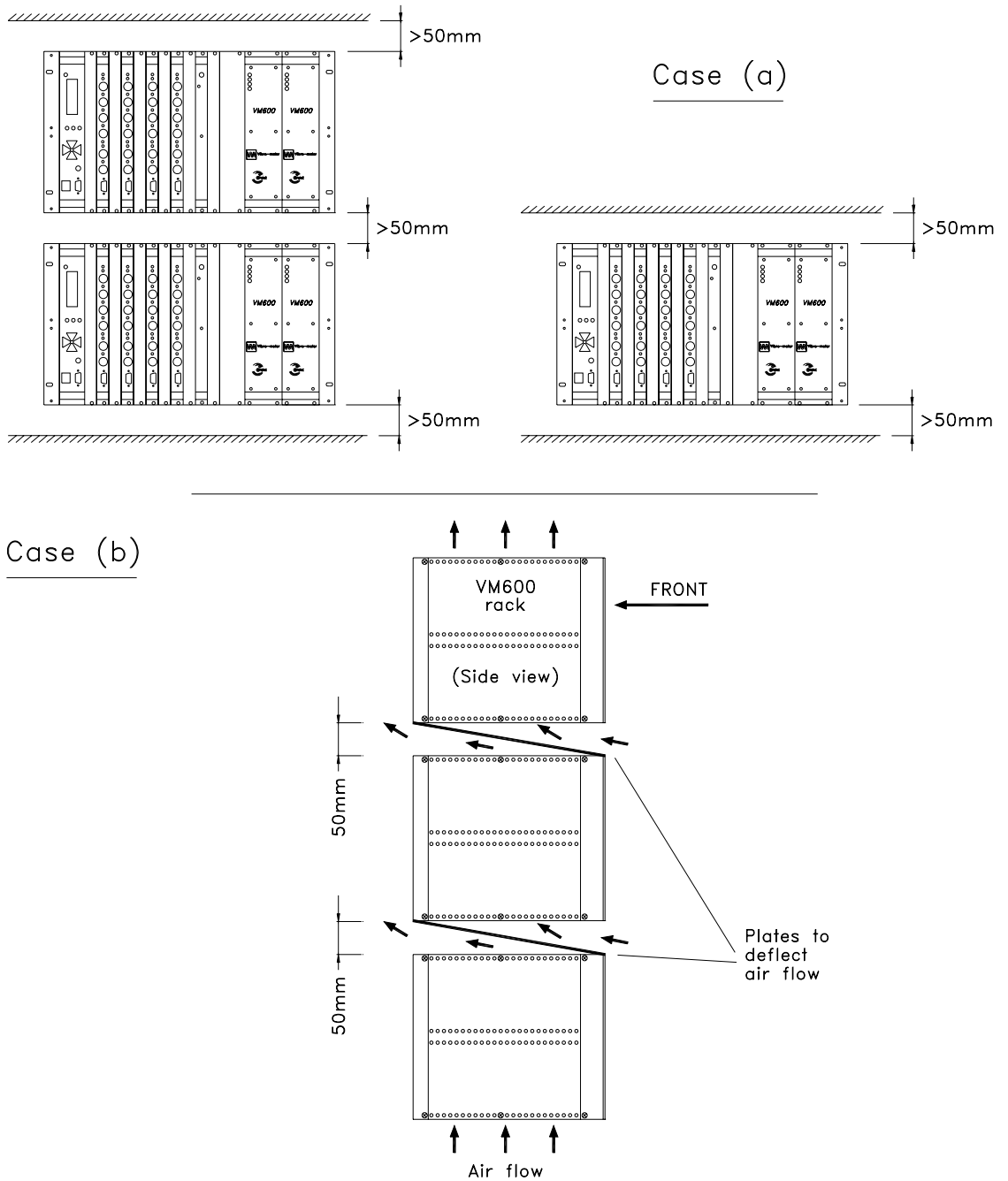

Figure 3-2 : Minimum required spacing below, above and between racks in an enclosure using natural ventilation

3.4 Installation Procedure for Cards



Operating personnel should remember to observe the handling precautions mentioned in *General Handling Precautions* on page xi when handling cards. Failure to do this may result in cards becoming damaged by electrostatic discharges.



Before inserting a card in the rack, check visually that none of the connector pins are bent.

3.4.1 First-Time Installation of the CMS



The initial insertion of elements in the ABE 04X rack should be done with the rack powered down.

When a CMS is installed for the first time, the pairs of CMC 16 / IOC 16T cards within it must be configured according to their intended application.

The IOC 16T cards have adjustable hardware elements (micro-switches and rotary switches) that have to be set up before insertion in the rack. This is described in 4.4 - Configuration of IOC 16T Cards.

The CMC 16 cards have only one user-adjustable hardware element (a DIP switch package). Refer to 4.5.2 - DIP Switch Package for further information.

NOTE : The elements on the IOC 16T and CMC 16 cards are normally configured in the factory before delivery of the CMS.

Note, however, that the configuration of individual channels on the CMC 16 must be done by software before the system can be used. This is done by using the VM600 CMS Software package, once the rack is powered up. The configuration can be downloaded from the PC or server via an RS-485 multi-drop link which connects all IOC 16T cards together in a “daisy-chain” manner. Alternatively, if the rack contains a CPU M card (and, optionally, its matching IOC N card), the configuration can be downloaded over an Ethernet link.

The majority of CMC 16 parameters will normally have been configured in the factory before delivery of the CMS. The customer is nevertheless able to modify all parameters if he wishes by using the VM600 CMS Software package.

NOTE : Refer to the relevant software manual for further information.

3.4.2 Subsequent Installation of Cards ("Live Insertion" Capability)

It is necessary to power down the ABE 04X rack before inserting or removing any of the following elements:

- CPU M
- IOC N
- RPS 6U. In racks employing a single RPS 6U power supply unit

The following elements have "live insertion" capability, i.e. they can be removed from / inserted in the CMS rack while it is powered up:

- CMC 16
- IOC 16T
- RPS 6U A single RPS 6U power supply unit may be replaced in racks employing two such units (one of the power supplies being "redundant")

The overall configuration of a CMC 16 card and its associated IOC 16T card is specific to a given slot in the rack. It depends on the type of hardware (transducer / conditioner or other system) connected to the IOC 16T, as well as the internal routing of signals over the rack backplane (via the Raw Bus or Tacho Bus).

The CMC 16 has no configurable hardware elements, but its software configuration is stored in an on-board non-volatile memory (NVRAM). When a new CMC 16 card is installed, this configuration is automatically downloaded from the host PC to the new card.

For the IOC 16T card, the adjustable hardware elements (micro-switches and rotary switches) have to be set up appropriately by the user on any new card put into a given slot.



You should set up the hardware configuration of a replacement IOC 16T card before installing it in a given slot.

Failure to do this can lead to measurement errors or incorrect operation of the CMS.

3.4.3 Setting the IP Address of the CPU M Card

The IP address of the CPU M must be defined for racks employing this type of card. Follow the procedure below:

- 1- Connect the CPU M to a VT 100 terminal emulator using an RS-232 serial cable. This cable should have a 9-pin male and a 9-pin female DB9 connector. These cables are available from Vibro-Meter: P/N = 957.18.09.030X
- 2- Required VT 100 terminal setup:
 - 57600 baud
 - 8 bits
 - 1 stop bit
 - No parity bit
- 3- Hit the <Enter> key to obtain the login prompt and log on under:
Username: user <Enter>
Password: config <Enter>
- 4- Use the vi text editor to modify the IP address in the "hosts" file. To call up the vi editor, type "vi hosts". You can move to the IP address using the arrow keys. To delete a character, type x. To insert new text, type i, then escape to finish. To leave the editor without saving changes, type "q!". To leave the editor and save changes, type ":wq".

For further information on vi, refer to <http://www.eng.hawaii.edu/Tutor/vi.html>

- 5- Reboot the CPU M by typing:
shutdown -f

NOTE : Refer to Appendix A of the *MPS1 Configuration Software Manual* for further information on the installation of a network connection.

THIS PAGE INTENTIONALLY LEFT BLANK

4 ELECTRICAL DESCRIPTION

4.1 Introduction

In order to gain an understanding of the operation of the CMS, it is necessary to consider the interaction of the principal elements making up this system, namely:

- CMC 16 Machinery protection card
- IOC 16T Input/output card (matching the CMC 16)
- ABE 04X 6U Rack (which houses the system backplane) RPS 6U Rack power supply

A block diagram of these elements is shown in Figure 4-1. This schematic diagram shows the backplane, which physically divides the ABE 04X rack into a front card cage and a rear card cage.

The CMC 16 (shown on the left of the diagram) is mounted in the front card cage. This card effects the signal processing functions for the CMS. Its front panel contains a LED indicator (DIAG) to show the hardware status and a reset button (RESET).

Each CMC 16 card is necessarily connected (via the backplane) to an IOC 6T input/output card mounted in the rear card cage. This card's front panel (found on the rear of the rack) has screw terminals for connecting the signal transmission lines coming from external measuring systems (e.g. from systems measuring vibration, pressure, temperature, etc.). It also contains two RJ11 type connectors for multi-drop RS-485 serial communication with the host PC.

4.2 CMS General Block Diagram

The block diagram in Figure 4-1 shows the interaction between the CMC 16 and IOC 16T cards.

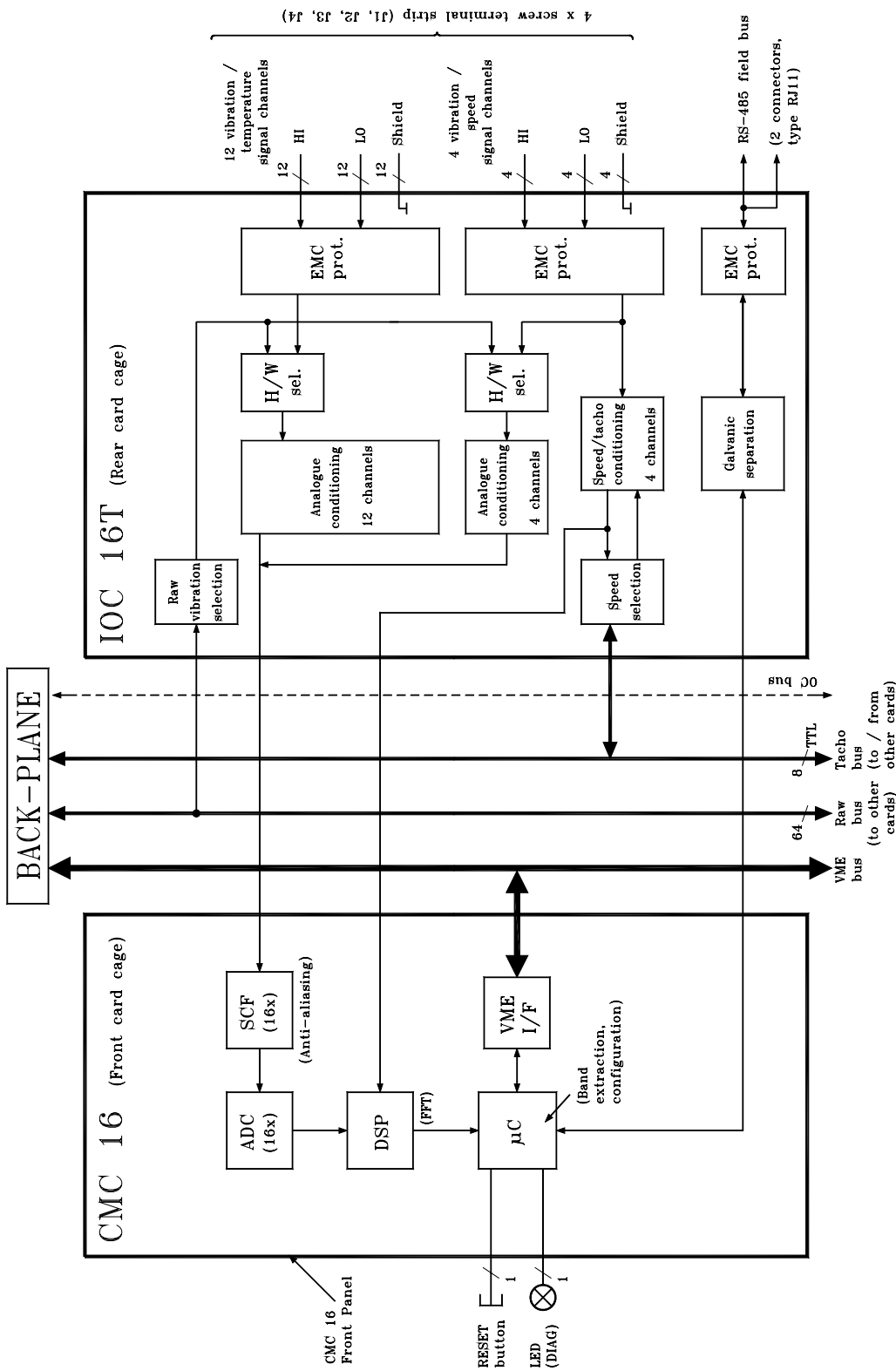

ADC = Analogue-to-Digital Converter, DSP = Digital Signal Processor, EMC = Electro-Magnetic Compatibility, H/W sel. = Hardware Selectable, I/F = Interface, μC = Micro-Controller, SCF = Switched-Capacitor Filter, VME = VersaBUS Module Eurocard

Figure 4-1 : Block diagram of CMC 16 and IOC 16T cards

4.3 VM 600 Backplane

4.3.1 Overview

The CMS uses a custom-designed backplane combining features of a VME backplane and special Vibro Meter features (refer to Figure 4-2 and Figure 4-3).

This backplane consists of 3 different systems:

- A VME bus (P1)
- An analogue bus (P3), opposite P1
- Through connections between P2 and P4

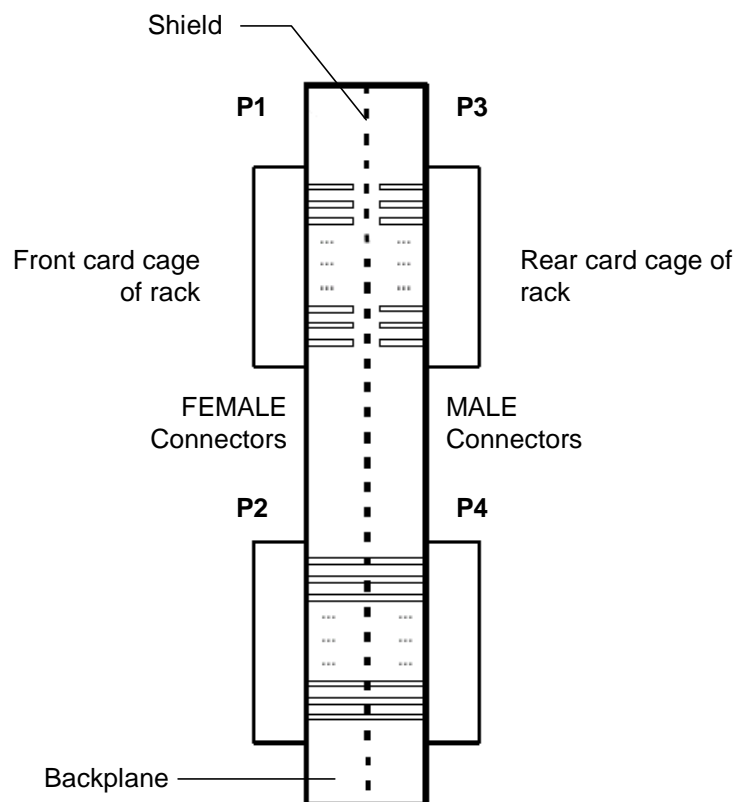

Figure 4-2 : Cross section of backplane showing the 4 connectors

A standard VME bus is used for the P1 bus on the front side of the backplane. This allows 24-bit address and 16-bit data transfers between cards in the rack.

According to the VME standard, normally the central row of the P2 bus is used to transfer the upper 16 bits of data and the upper 8 bits of address for extended 32-bit address and 32-bit data transfers. This is the case for VME Slots 0, 1 and 2 of the ABE 04X rack, which correspond fully to the VME 32 specifications. In practice, Slot 0 is reserved for the optional CPU M card (modular CPU card acting as rack controller). This card has a width of 3 slots, so consequently Slots 1 and 2 cannot be used if the CPU M card is installed. Otherwise, Slots 1 and 2 may be used for VME 32 standard cards.

The situation for Slots 3 to 14 is as follows: for each of these slots, the P2 connector is needed to connect the card in the front card cage to the card immediately behind it in the rear card cage (connections between P2 and P4). This excludes 32-bit VME transfers for these cards, meaning they correspond to the VME 16 specifications.

Slot 15 and Slot 18 of the rack are intended for RPS 6U rack power supply units. The backplane is equipped with special high-current connectors (type H15) for these units.

Bus P3 in fact encompasses the following three buses:

- The Tacho Bus
This is composed of 8 lines. These lines have passive terminations. The Tacho Bus is common to all slots in the rack. It is intended for the transfer of speed and phase reference signals between cards. Refer to 4.3.2 - The Tacho Bus for further information.
- The Raw Bus
This is composed of 32 x 2 lines. These lines do not have terminations.
The Raw Bus is common to all slots in the rack.
Refer to 4.3.3 - The Raw Bus for further information.
- The Open Collector (OC) Bus

NOTE : The OC Bus is intended for use in the VM 600 Series Machinery Protection System (MPS). It is not accessible to the CMC 16 and IOC 16T cards, so will not be described in this manual.

Refer to the VM 600 Series MPS instruction manual (Doc. No. 665.040) for further information.

The Tacho Bus, Raw Bus and OC Bus are not “buses” in the microcomputing sense of the term (i.e. there is no protocol, handshaking, timing, etc.). They should be thought of as groups of lines that can be used to transmit signals.

NOTE : Refer to Appendix B for full details on connectors P1, P2, P3 and P4.

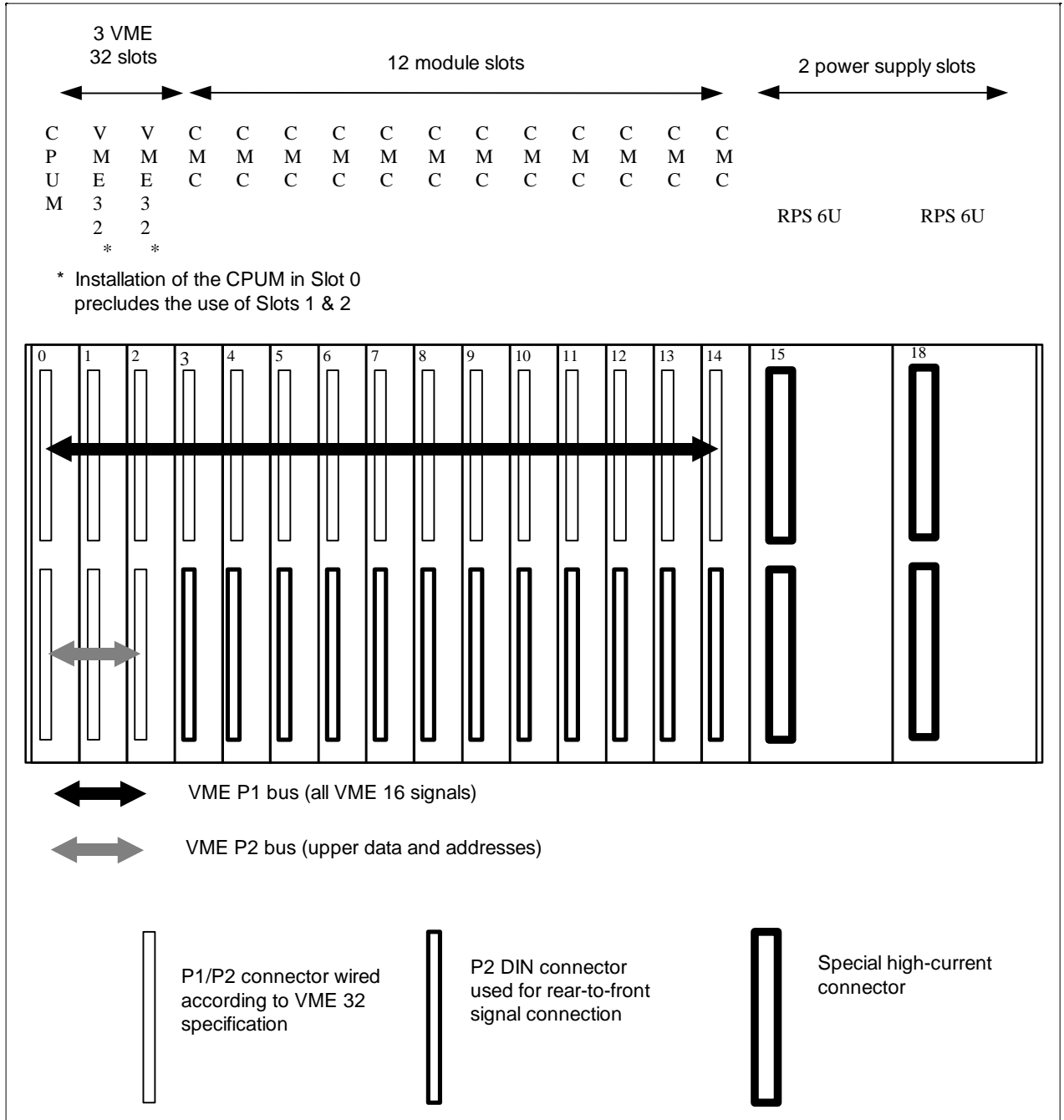

Figure 4-3 : Schematic of CMS backplane showing layout and connections

4.3.2 The Tacho Bus

The Tacho Bus has 8 lines and is common to all slots in the rack. It is intended for the transfer of speed (tacho) signals between cards. A signal on a given Tacho Bus line may be used by more than one card.

In a rack having mixed MPS / CMS capability, speed signals may be placed on the Tacho Bus from the IOC 4T card. This is done by setting multiplexers under software control.

NOTE : Refer to the VM 600 Series MPS instruction manual (Doc. No. 665.040) for further information.

In a rack containing only CMS hardware (CMC 16 and IOC 16T cards), speed signals can be placed on / taken off the Tacho Bus by setting the appropriate hardware elements on the IOC 16T cards (Figure 4-4). This is possible only for the first 4 of the 16 channels on each card.

The rotary switch SW9 can be set to one of 9 positions. Positions 1 to 8 are used to route the signal to / from the corresponding Tacho Bus line. The switch should be set to position 0 when the application does not require use of the Tacho Bus.

Channels 1 to 4 of the IOC 16T contain tacho signal conditioning circuitry to convert the local speed signal present on the rear connector into TTL level signals. This is followed by a circuit to enable / disable the conditioned signal (either blocking it, or sending it to the CMC 16 and SW9). This circuit is controlled by a micro-switch in the DIP switch package named SW7_4.

Further information on the use of SW9 and SW7_4 is given in 4.4.2.1 - Tacho Signals.

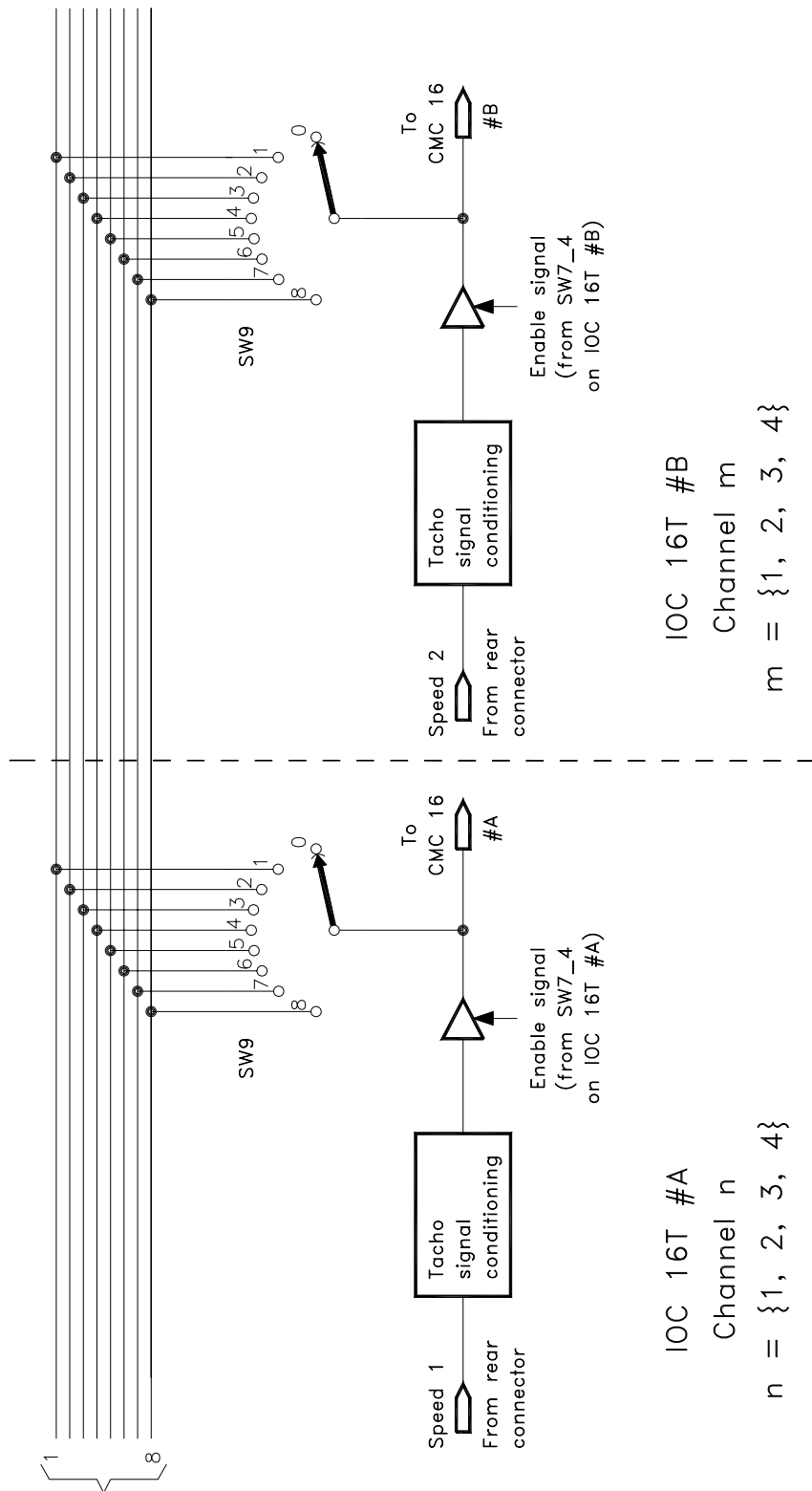

Figure 4-4 : Routing signals over the Tacho Bus

4.3.3 The Raw Bus

The Raw Bus contains 64 parallel bus lines. The ABE 04X system rack contains a single bus of this type. Unlike the MPC 4 / IOC 4T pair of cards used in the MPS, the CMC 16 / IOC 16T pair cannot put signals on to the Raw Bus. However, switches on the IOC 16T allow signals to be taken from it.

The Raw Bus therefore cannot be used in racks having only CMS capability. It is intended principally for racks with mixed MPS / CMS capability.

The IOC 4T card has a jumper matrix allowing raw analog signals to be placed on any bus line (refer to Figure 4-5). If a signal is required by a CMC 16 card, the appropriate switches must also be set on the corresponding IOC 16T card. Refer to 4.4.2 - Channels 1 to 4 (Tacho, Vibration & Analogue Signals).

NOTE : Refer to the VM 600 Series MPS instruction manual (Doc. No. 665.040) for further information on putting signals on the Raw Bus.

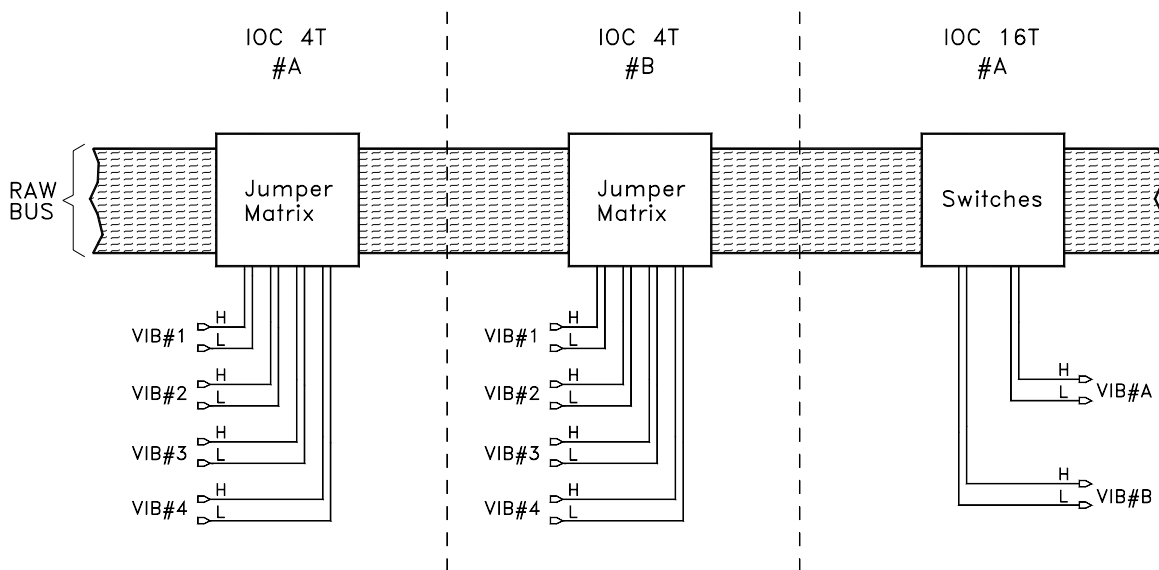

Figure 4-5 : Use of the Raw Bus to transfer analog signals between cards

4.4 Configuration of IOC 16T Cards

This section describes how to obtain a given configuration by changing the hardware settings of the switches and jumpers on the IOC 16T and CMC 16 cards. However, the recommended and easiest method for configuring a CMS system is to define the software configuration of the card first, using the Configuration Editor. Once this has been done, the hardware settings can be performed by printing out the jumper matrix and using it as a guide.

For full details, refer to the *VM 600 Condition Monitoring System (CMS) Software Manual*, and in particular section 8, Creating a Rack Configuration, in that manual.

4.4.1 Position of User-Adjustable Elements on the IOC 16T

Figure 4-6 shows the layout of user-adjustable elements for all 16 channels.

4.4.2 Channels 1 to 4 (Tacho, Vibration & Analogue Signals)

This description is relevant to Channels 1 to 4, which can process Tacho, Vibration & Analogue signals.

Figure 4-7 shows the processing applied to these signal types, and indicates the user-adjustable switches associated with these 4 channels. These elements must be set up during the configuration of a rack in order to customize each channel. The necessary settings can be determined from Figure 4-8. The physical location of these elements on the IOC 16T card is shown in Figure 4-6.

Further information on signal processing is given in 4.4.2.1 - Tacho Signals and 4.4.2.3 - Vibration and Analogue Signals.

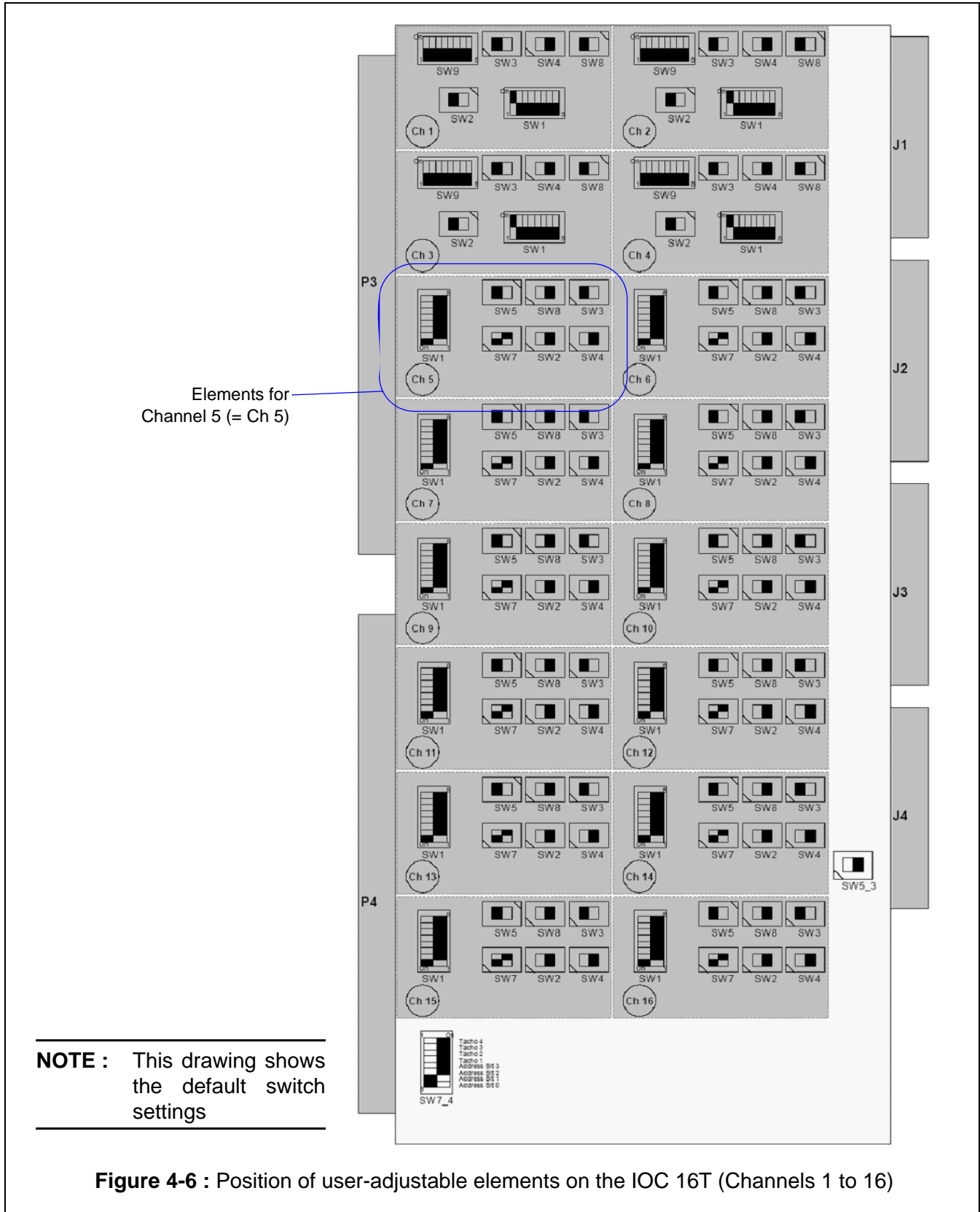

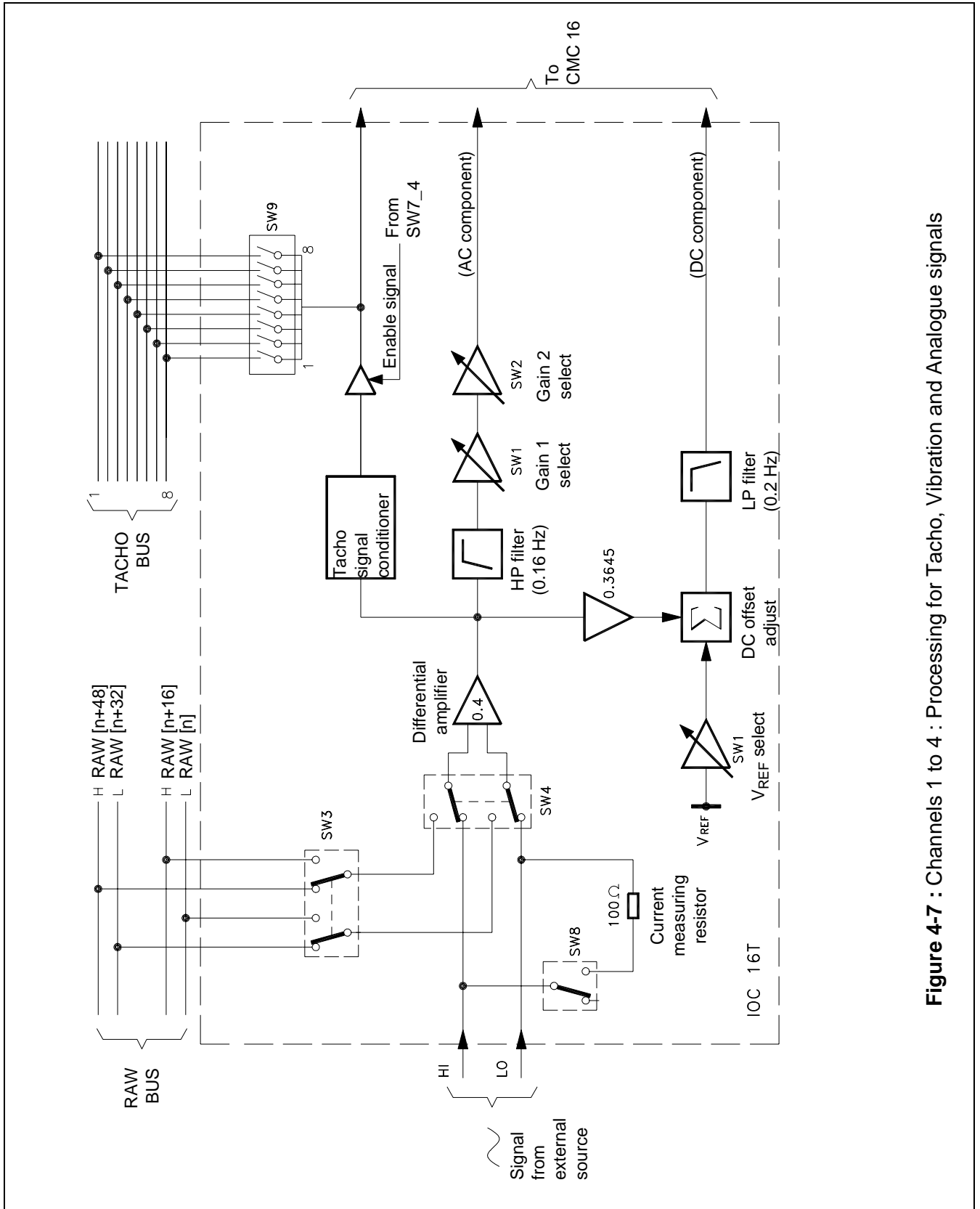
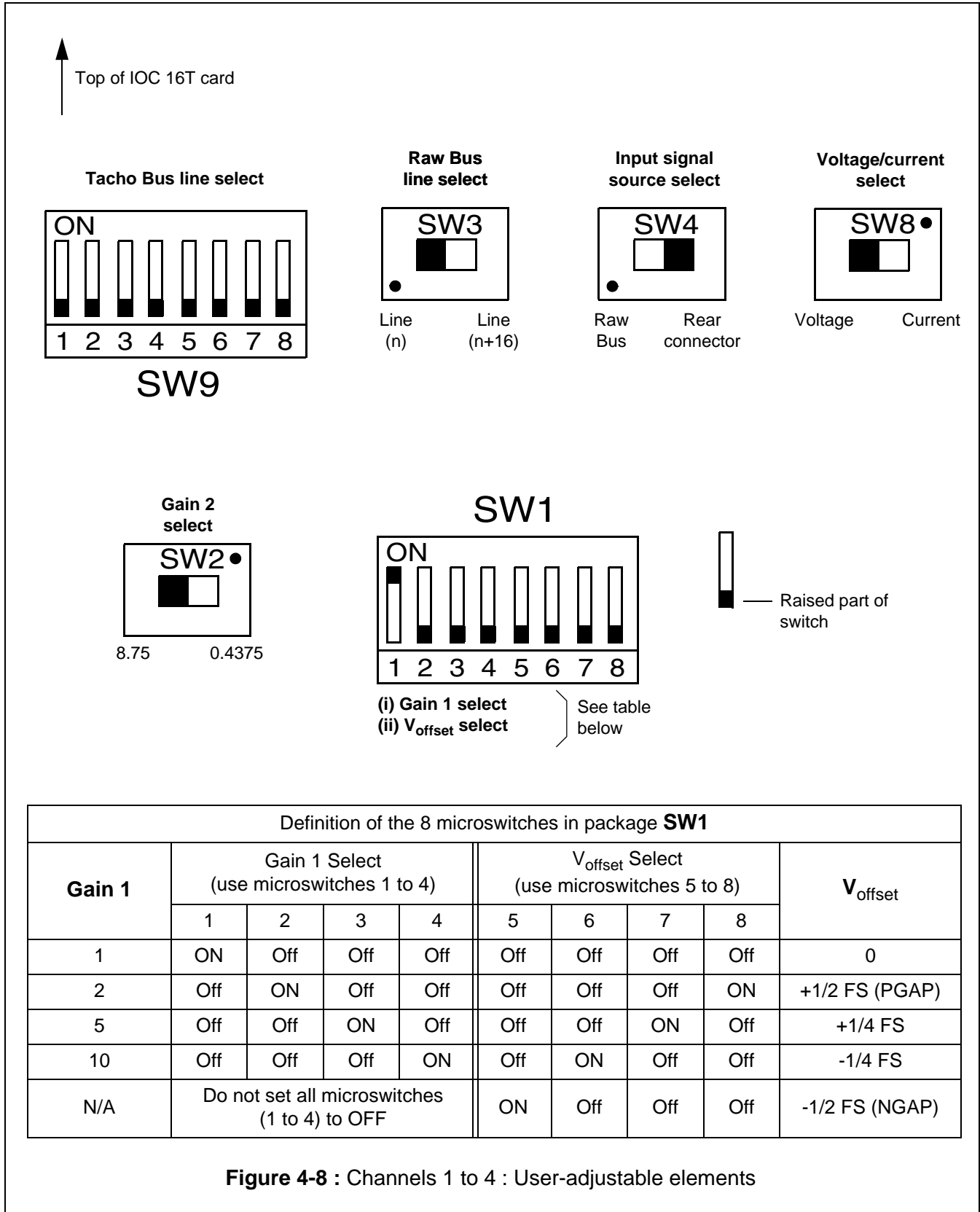

Figure 4-7 : Channels 1 to 4 : Processing for Tacho, Vibration and Analogue signals



4.4.2.1 Tacho Signals

Tacho signals can be taken from either of the following sources (see Figure 4-7):

- The rear connector of the IOC 16T card

This is known as using a “local” signal

- The Tacho Bus

This is known as using a “remote” signal

A Tacho signal will not normally be taken from the Raw Bus.

To take a signal from the rear connector, switch SW4 must be set accordingly to allow the signal to be amplified, then passed to the Tacho signal conditioner circuitry. The signal must then be enabled to allow it to pass to the CMC 16 card. The enabling circuit is controlled by one of the microswitches in the DIP package called SW7_4 (refer to Figure 4-9).

As well as being sent to the CMC 16, the signal leaving the enabling circuit may be routed onto one of the 8 Tacho Bus lines. This allows it to be used by other cards in the rack. The appropriate microswitch within the package SW9 should be used to select the Tacho line, as shown in Figure 4-7. For example, set microswitch 2 to ON to select Tacho Bus line 7. Set all microswitches of SW9 to OFF if you do not want to place a signal on the Tacho Bus.

Likewise, to take a signal from a Tacho Bus line, the appropriate microswitch in package SW9 should be set to ON (see Figure 4-7).

In this case, any signal coming from the rear connector must be blocked by the enabling circuit in order to avoid a conflict of signals. The appropriate microswitch in package SW7_4 should be set accordingly. See 4.4.2.2 - Switch Package SW7_4 and Figure 4-9 for details.

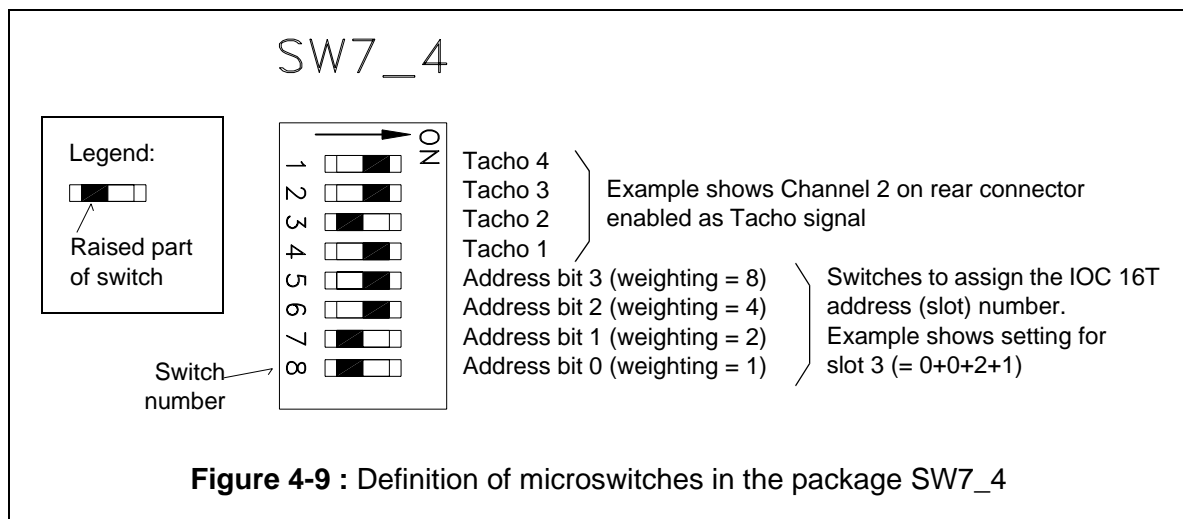

Figure 4-9 : Definition of microswitches in the package SW7_4

4.4.2.2 Switch Package SW7_4

Microswitches 1 to 4

Microswitches 1 to 4 of package SW7_4 are used to control the Tacho signal enabling circuits for Channels 1 to 4. Note, however, the following attribution of switches:

- Microswitch 1 is used to control Channel 4
- Microswitch 2 is used to control Channel 3
- Microswitch 3 is used to control Channel 2
- Microswitch 4 is used to control Channel 1

When a microswitch is pushed to the left (to the “Off” position), a Tacho signal coming from the rear connector is enabled and sent on to SW9 and the CMC 16 card.

When a switch is pushed to the right (to the ON position), a signal coming from the rear connector is blocked. This allows a signal to be taken off the Tacho Bus (by setting the microswitches in SW9 accordingly) without any risk of a conflict of signals.

In the example shown in Figure 4-9, the Tacho signal for Channel 2 present on the rear connector is enabled and passed on to the CMC 16. The Tacho signals for Channels 1, 3 and 4 present on the rear connector are blocked.

Microswitches 5 to 8

These 4 microswitches are used to assign the address (slot) number of the IOC 16T card as shown in Table 4-1.

NOTE : When considering the weighting of switches making up the slot address, remember that a microswitch has to be set to “Off” to become active. For example, switch 7 set to Off provides a weighting of 2 and switch 8 set to Off provides a weighting of 1.

Microswitch settings (on SW7_4)				Slot Number	Comment
Switch 5 (Weighting = 8)	Switch 6 (Weighting = 4)	Switch 7 (Weighting = 2)	Switch 8 (Weighting = 1)		
ON	ON	ON	ON	0	Not applicable to CMS (slot 0 reserved for IOC N)
ON	ON	ON	Off	1	Reserved
ON	ON	Off	ON	2	
ON	ON	Off	Off	3	Valid configuration for CMS
ON	Off	ON	ON	4	Valid configuration for CMS
ON	Off	ON	Off	5	Not applicable to CMS (rack has only 5 slots)
ON	Off	Off	ON	6	
ON	Off	Off	Off	7	
Off	ON	ON	ON	8	
Off	ON	ON	Off	9	
Off	ON	Off	ON	10	
Off	ON	Off	Off	11	
Off	Off	ON	ON	12	
Off	Off	ON	Off	13	
Off	Off	Off	ON	14	

Table 4-1 : Microswitch settings to assign a slot number to an IOC 16T card

4.4.2.3 Vibration and Analogue Signals

Vibration and Analogue signals can be taken from either of the following sources by setting switch SW4 accordingly:

- The rear connector of the IOC 16T card.

- The Raw Bus

NOTE : The ability to take signals from the Raw bus is only available in mixed MPS/CMS systems, since the IOC 16T card can only take signals from the Raw bus: it cannot place them on it.

The AC and DC components of Vibration signals are split and processed separately on the IOC 16T card (see Figure 4-7). The two components are subsequently remixed on the CMC 16 card.

Processing parameters such as gain and DC offset are set up with the user-adjustable hardware elements (switches and microswitches). This is described further in 4.4.2.4 - Description of Individual Switches (Channels 1 to 4).

4.4.2.4 Description of Individual Switches (Channels 1 to 4)

NOTE : Refer to Figure 4-7 and Figure 4-8.

1- Switches **SW1** and **SW2** (AC gain)

These switches are used together to set the AC gain and full-scale deviation (FSD). Refer to Table 4-2 for all possible combinations.

FSD (Volts)	Overall Gain	SW1 Setting (see Figure 4-8)	SW2 Setting
0.1	35	Microswitch 4 = ON	Left
0.2	17.5	Microswitch 3 = ON	Left
0.5	7	Microswitch 2 = ON	Left
1	3.5	Microswitch 1 = ON	Left
2	1.75	Microswitch 4 = ON	Right
4 (5)	0.875	Microswitch 3 = ON	Right
10	0.35	Microswitch 2 = ON	Right
20	0.175	Microswitch 1 = ON	Right

Table 4-2 : Using SW1 and SW2 to set the AC gain and FSD

NOTE : Do not set all 4 microswitches (1, 2, 3 and 4) of SW1 to "Off" at the same time as this will configure the amplifier in an open loop.

2- Switch **SW1** (V_{offset} select)

Microswitches 5, 6, 7 and 8 of package SW1 select the offset to be added (see Table 4-3).

SW1 Setting (see Figure 4-8)	Connection Type (from V_{ref} to DC Offset Adjust Summer)	V_{ref} Gain	Offset Added
Microswitch 8 = ON	Direct to $+V_{ref}$	+1	+0.5 x FS
Microswitch 7 = ON	To $+V_{ref}$ via a 76.8 k Ω resistor	+0.5	+0.25 x FS
Microswitch 6 = ON	To $-V_{ref}$ via a 76.8 k Ω resistor	-0.5	-0.25 x FS
Microswitch 5 = ON	Direct to $-V_{ref}$	-1	-0.5 x FS
All 4 switches off	No connection	0	0

Table 4-3 : Using SW1 to select the offset

- FS is defined as being the full scale on the output of the IOC 16T card and has a value of 3.5 V.
- The value of $V_{ref} = 0.5 \times FS = 0.5 \times 3.5 \text{ V} = 1.75 \text{ V}$.

3- Switch **SW3** (Raw Bus line select)

- Left : Line (n) High and Line (n) Low are connected to the H and L inputs of the differential amplifier, respectively.
- Right : Line (n+16) High and Line (n+16) Low are connected to the H and L inputs of the differential amplifier, respectively.

NOTE 1 : As mentioned above, this feature is only accessible in mixed MPS/CMS systems, since the IOC 16T card can only take signals from the Raw bus: it cannot place them on it.

4- Switch **SW4** (Input signal source select)

- Left : Input amplifier gets its signal from the selected Raw Bus lines (depends on setting of SW3).
- Right : Input amplifier gets its signal from the rear connector of the IOC 16T.

5- Switch **SW8** (Voltage / current select)

- Left : To measure a voltage-based signal.
- Right : To measure a current-based signal (using a 100 Ω current measuring resistor).

6- Switch **SW9** (Tacho Bus line select)

SW9 Setting (see Figure 4-8)	Tacho Bus Line Selected
Microswitch 8 = ON	Line 1
Microswitch 7 = ON	Line 2
Microswitch 6 = ON	Line 3
Microswitch 5 = ON	Line 4
Microswitch 4 = ON	Line 5
Microswitch 3 = ON	Line 6
Microswitch 2 = ON	Line 7
Microswitch 1 = ON	Line 8
All microswitches are "Off"	No Tacho Bus line selected

Table 4-4 : Selecting a Tacho Bus line with SW9

4.4.3 Channels 5 to 16 (Vibration, Analogue & Thermocouple Signals)

This description is relevant to Channels 5 to 16, which can process Vibration, Analogue or Thermocouple signals.

Channel 16 is a special case as it can also be used to connect a temperature sensor to provide cold-junction compensation for thermocouples connected to Channels 5 to 15. Refer to 4.4.4 - Channel 16 for further information.

Figure 4-10 shows the processing applied to Vibration, Analogue and Thermocouple signal types, and indicates the user-adjustable hardware elements (switches and microswitches) associated with Channels 5 to 15. These elements must be set up during the configuration of a CMS rack in order to customize each channel. The necessary settings can be determined from Figure 4-11. The physical location of these elements on the IOC 16T card is shown in Figure 4-6.

Further information on signal processing is given in 4.4.3.1 - Vibration and Analogue Signals and 4.4.3.2 - Thermocouple Signals.

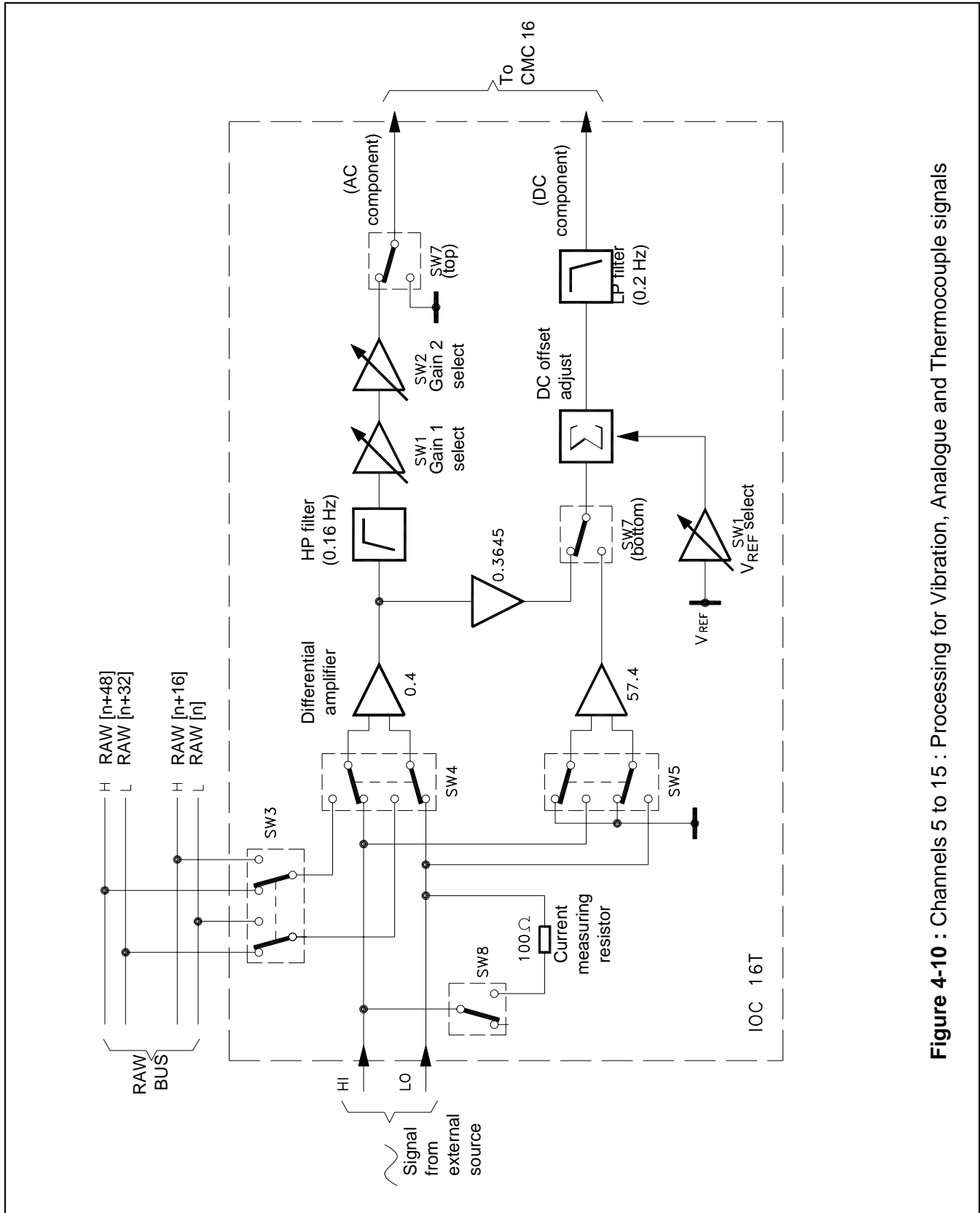
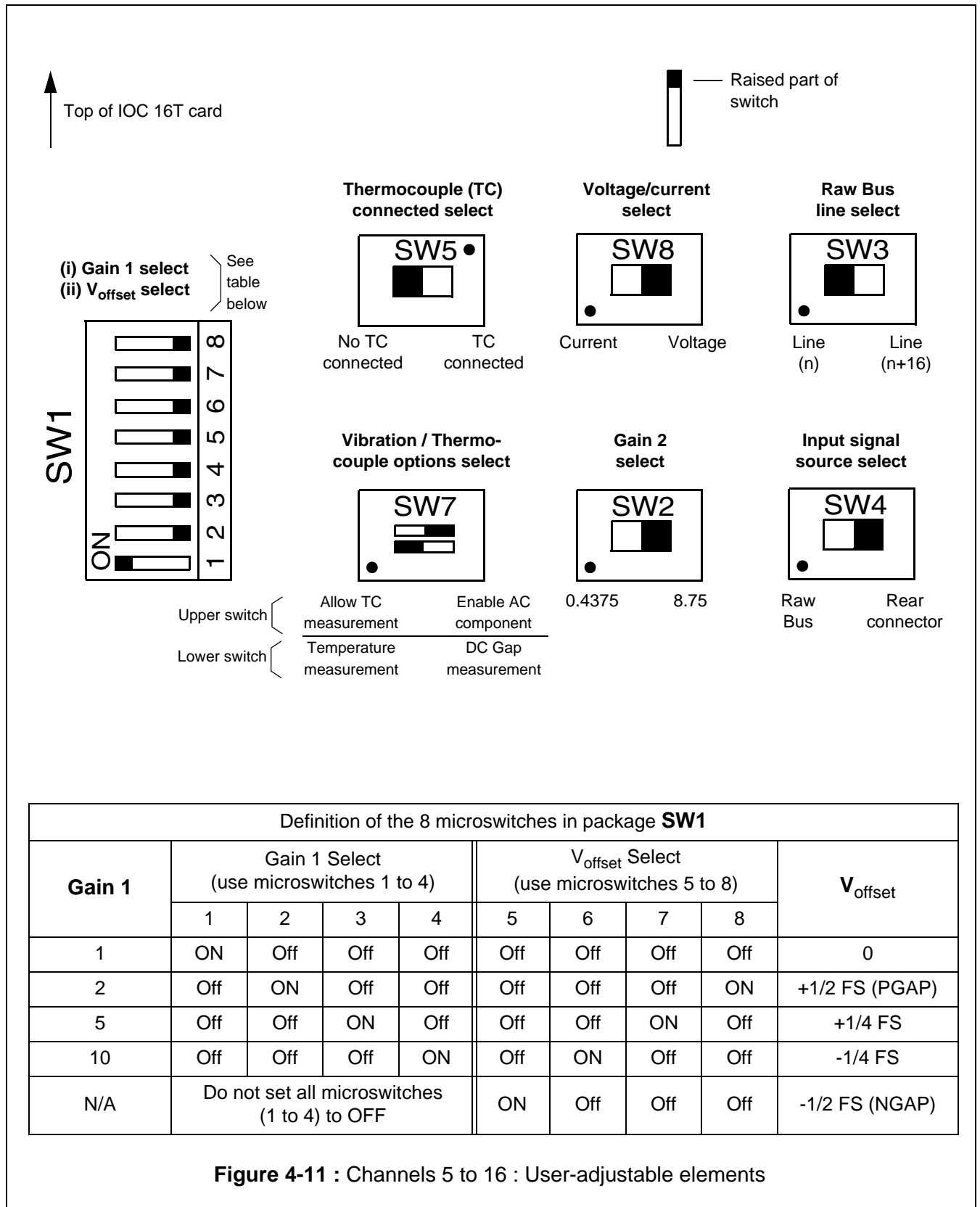

Figure 4-10 : Channels 5 to 15 : Processing for Vibration, Analogue and Thermocouple signals



4.4.3.1 Vibration and Analogue Signals

The processing of Vibration and Analogue signals by Channels 5 to 15 is identical to that performed on these signal types by Channels 1 to 4.

NOTE : Refer to 4.4.2.3 - Vibration and Analogue Signals for further information on the processing of these signal types.

4.4.3.2 Thermocouple Signals

Thermocouple signals can be taken only from the rear connector of the IOC 16T card.

Switch SW5 must be set to the right to allow the incoming thermocouple signal to be amplified (gain = 57.4). Refer to Figure 4-10 and Figure 4-11.

The bottom switch of the package SW7 must be set to the left to allow the amplified signal to pass to the summer circuit (DC offset adjust). From here, the signal is low-pass filtered and then routed to the CMC 16 card.

The top switch of the package SW7 must be set to the left to ground the AC component that is routed to the CMC 16 card. This prevents the temperature measurement from being disturbed by AC noise.

Refer to 4.4.3.3 - Description of Individual Switches (Channels 5 to 16) for further information.

4.4.3.3 Description of Individual Switches (Channels 5 to 16)

NOTE : Refer to Figure 4-10 and Figure 4-11.

1- Switches SW1 and SW2 (AC gain)

These switches are used together to set the AC gain and full-scale deviation (FSD). Refer to Table 4-10 for all possible combinations.

FSD (Volts)	Overall Gain	SW1 Setting (see Figure 4-11)	SW2 Setting
0.1	35	Microswitch 4 = ON	Left
0.2	17.5	Microswitch 3 = ON	Left
0.5	7	Microswitch 2 = ON	Left
1	3.5	Microswitch 1 = ON	Left
2	1.75	Microswitch 4 = ON	Right
4 (5)	0.875	Microswitch 3 = ON	Right
10	0.35	Microswitch 2 = ON	Right
20	0.175	Microswitch 1 = ON	Right

Table 4-5 : Using SW1 and SW2 to set the AC gain and FSD

NOTE : Do not set all 4 microswitches (1, 2, 3 and 4) of SW1 to "Off" at the same time as this will configure the amplifier in an open loop.

2- Switch SW1 (V_{offset} select)

Microswitches 5, 6, 7 and 8 of package SW1 select the offset to be added (see Table 4-6).

SW1 Setting (see Figure 4-11)	Connection Type (from V_{ref} to DC Offset Adjust Summer)	V_{ref} Gain	Offset Added
Microswitch 8 = ON	Direct to $+V_{ref}$	+1	+0.5 x FS
Microswitch 7 = ON	To $+V_{ref}$ via a 76.8 k Ω resistor	+0.5	+0.25 x FS
Microswitch 6 = ON	To $-V_{ref}$ via a 76.8 k Ω resistor	-0.5	-0.25 x FS
Microswitch 5 = ON	Direct to $-V_{ref}$	-1	-0.5 x FS
All 4 switches off	No connection	0	0

Table 4-6 : Using SW1 to select the offset

- FS is defined as being the full scale on the output of the IOC 16T card and has a value of 3.5 V.
- The value of $V_{ref} = 0.5 \times FS = 0.5 \times 3.5 \text{ V} = 1.75 \text{ V}$.

3- Switch **SW3** (Raw Bus line select)

- Left : Line (n) High and Line (n) Low are connected to the H and L inputs of the differential amplifier, respectively.
- Right : Line (n+16) High and Line (n+16) Low are connected to the H and L inputs of the differential amplifier, respectively.

This switch is relevant only for Vibration and Analogue signals. It is not relevant for Thermocouple signals as the Raw Bus cannot be used to transmit this signal type.

NOTE 2 :As mentioned above, this feature is only accessible in mixed MPS/CMS systems, since the IOC 16T card can only take signals from the Raw bus: it cannot place them on it.

4- Switch **SW4** (Input signal source select)

- Left : Input amplifier gets its signal from the selected Raw Bus lines (depends on setting of SW3).
This setting is valid for Vibration and Analogue signals, but not for Thermocouple signals.
- Right : Input amplifier gets its signal from the rear connector of the IOC 16T.

5- Switch **SW5** (Thermocouple (TC) connect select)

- Left : This setting must be used when no thermocouple is connected. This is the case when measuring Vibration or Analogue signals.
- Right : This setting must be used when a thermocouple is connected.

6- Switch **SW7 - Top** (Vibration / thermocouple options)

- Left : This setting must be used when a thermocouple is connected.
This grounds the AC component routed to the CMC 16 card.
- Right : This setting must be used when measuring Vibration or Analogue signals.

7- Switch **SW7 - Bottom** (Vibration / thermocouple options)

- Left : This setting must be used when a thermocouple is connected.
- Right : This setting must be used when measuring Vibration or Analogue signals.
This allows the DC component to pass to the summer circuit.

8- Switch **SW8** (Voltage / current select)

- Left : To measure a voltage-based signal.

- Right : To measure a current-based signal (using a 100 Ω current measuring resistor).

4.4.4 Channel 16

Channel 16 is a variant of Channels 5 to 15. Like those 11 channels, Channel 16 can also process Vibration, Analogue or Thermocouple signals.

The particularity of Channel 16 is that it can also be used to connect a temperature sensor to provide cold-junction compensation for thermocouples connected to Channels 5 to 15.

Figure 4-12 shows the processing applied to the various signal types, and indicates the user-adjustable hardware elements (switches and microswitches) associated with Channel 16.

These elements must be set up during the configuration of a CMS rack in order to customize the channel. The physical location of these elements on the IOC 16T card is shown in Figure 4-6.

4.4.4.1 Vibration and Analogue Signals

The processing of Vibration and Analogue signals by Channel 16 is identical to that performed on these signal types by Channels 1 to 4 and Channels 5 to 15.

NOTE : Refer to 4.4.2.3 - Vibration and Analogue Signals for further information on the processing of these signal types.

4.4.4.2 Thermocouple Signals

The processing of Thermocouple signals by Channel 16 is identical to that performed on these signal types by Channels 5 to 15.

NOTE : Refer to 4.4.3.2 - Thermocouple Signals for further information on the processing of these signal types.

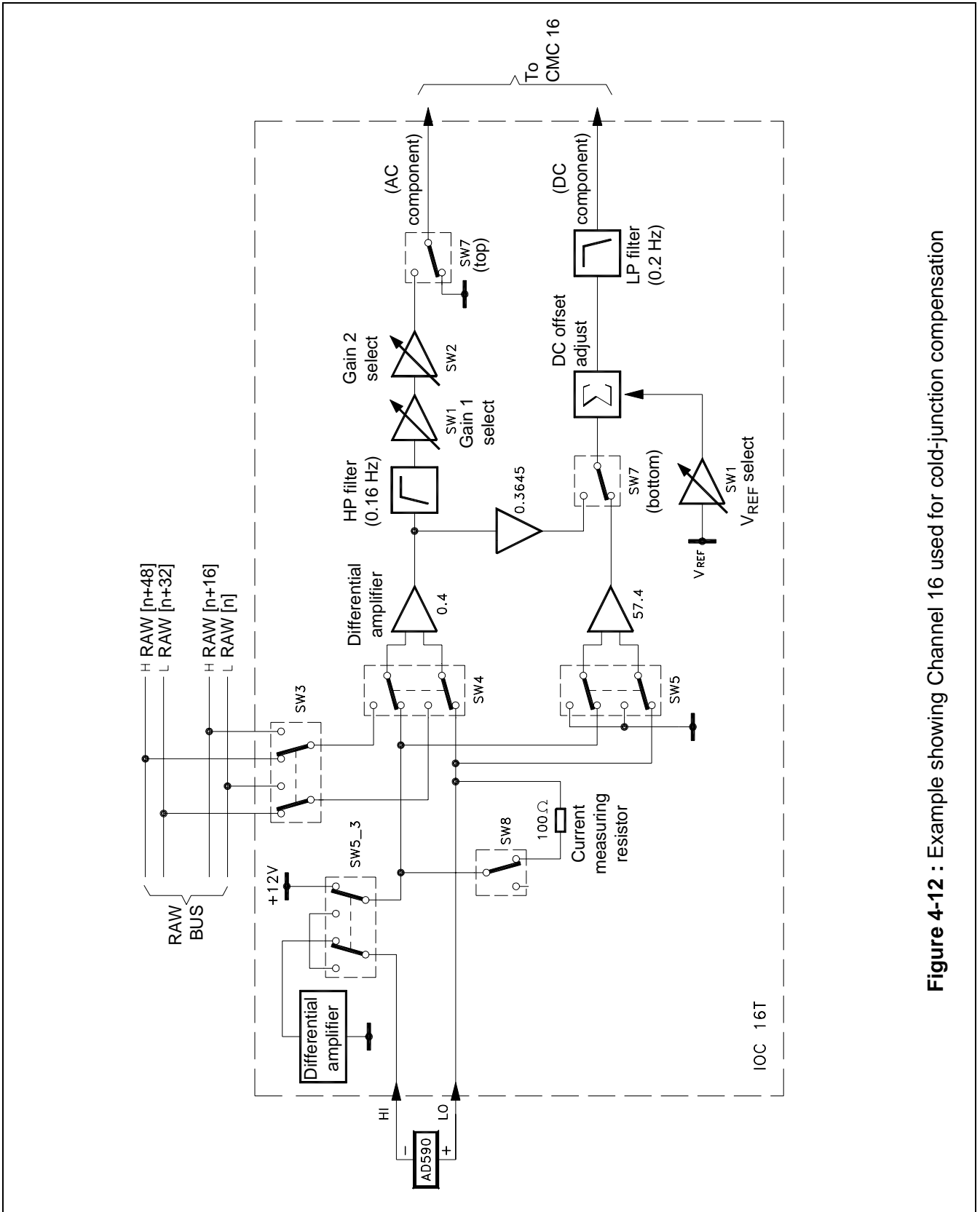

Figure 4-12 : Example showing Channel 16 used for cold-junction compensation

4.4.4.3 Using Channel 16 for Cold-Junction Compensation of Thermocouple Signals

An AD590 temperature sensor may be connected to Channel 16 to allow cold-junction compensation for thermocouples connected to Channels 5 to 15.

The AD590 is connected to Channel 16 as shown in Figure 4-12.

NOTE : Take care when connecting the AD590 as the - line must be connected to the HI input and the + line to the LO input of the channel.

The AD590 provides a current proportional to the absolute ambient temperature. At 273.2 K (i.e. 0°C) it outputs 273.2 μ A and this current changes by 1 μ A/K.

This current-based signal is transformed into a voltage-based signal by the 100 Ω current measuring resistor on the input to Channel 16. Switch SW8 must be set to the right to allow this.

Switch SW5_3 must be set to the left to power the AD590.

Set the following switches as shown below:

- SW5 : to the right
- SW7 - Top : to the left
- SW7 - Bottom : to the left

4.4.4.4 Description of Individual Switches (Channel 16)

The user-adjustable elements for Channel 16 are identical to those for Channels 5 to 15.

NOTE : Refer to Figure 4-11 and 4.4.3.3 - Description of Individual Switches (Channels 5 to 16) for further information.

The only additional element present for Channel 16 is switch SW5_3, which is only used when the channel is used for cold-junction compensation. The position of this element is shown in Figure 4-13.

Switch **SW5_3** (Cold-junction compensation (CJC) select)

- **Left** : This setting must be used when an AD590 temperature sensor is connected (i.e. when cold-junction compensation is needed on one or more of Channels 5 to 15).
 - **Right** : This setting must be used when no AD590 temperature sensor connected (i.e. no cold-junction compensation is needed).
- Use this setting when measuring Vibration, Analogue or Thermocouple signals.

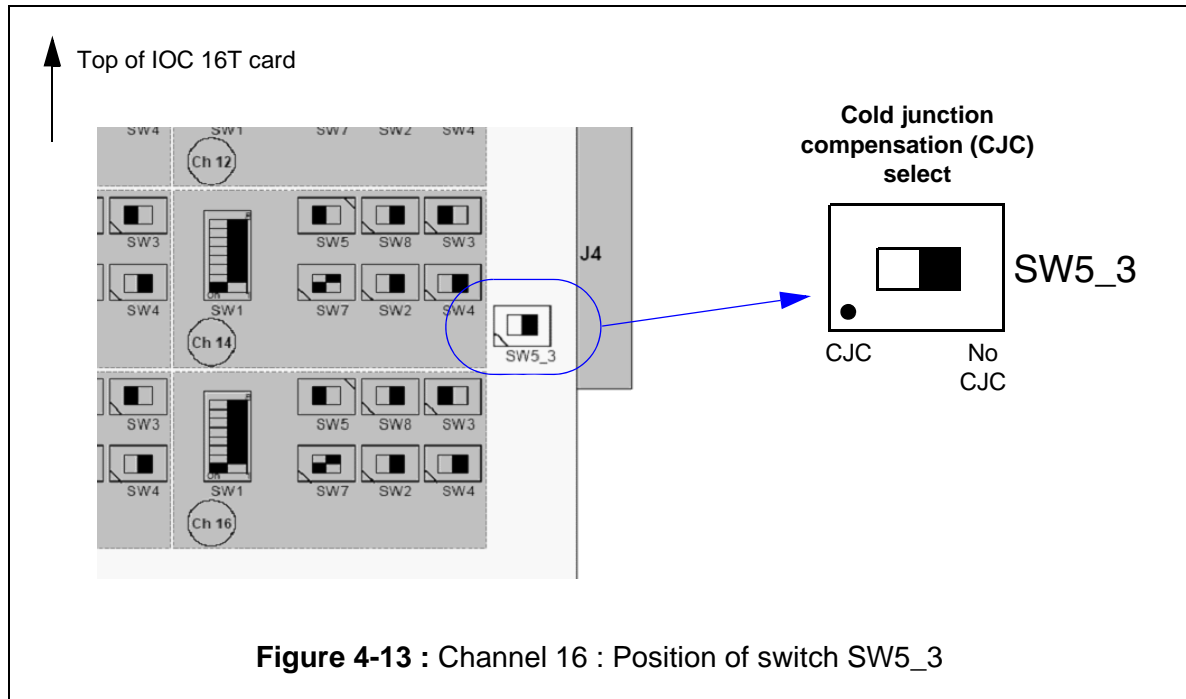

4.4.4.5 Summary of Switch Settings

The following tables provide an overview of the switch settings required for various functions. Refer to Table 4-7 for Vibration signals and Table 4-8 for Analogue and current-based signals. Table 4-9 gives details for Thermocouple (TC) signals and Table 4-10 for Tacho signals.

Available Channels	FSD on CMC 16 (peak value)	Remarks	Output Signal Range *(FS = 3.5 V _{AC} pk)	SW1 Switches 1 to 4	SW1 Switches 5 to 8	SW2	SW3	SW4	SW5	SW7 Top	SW7 Bottom	SW8	SW9
1 to 16	100 mV _{AC}	0 to peak (70.7 mV _{RMS})	0 to FS (AC peak)	4 = ON (Other 3 are OFF)	Def.	0 L: Ch 1 to 4 R: Ch 5 to 16	Def.	0 R	0 L	Def.	1 L	0 L: Ch 1 to 4 R: Ch 5 to 16	TBUS
1 to 16	200 mV _{AC}	0 to peak (141.4 mV _{RMS})	0 to FS (AC peak)	3 = ON (Other 3 are OFF)	Def.	0 L: Ch 1 to 4 R: Ch 5 to 16	Def.	0 R	0 L	Def.	1 L	0 L: Ch 1 to 4 R: Ch 5 to 16	TBUS
1 to 16	500 mV _{AC}	0 to peak (353.5 mV _{RMS})	0 to FS (AC peak)	2 = ON (Other 3 are OFF)	Def.	0 L: Ch 1 to 4 R: Ch 5 to 16	Def.	0 R	0 L	Def.	1 L	0 L: Ch 1 to 4 R: Ch 5 to 16	TBUS
1 to 16	1 V _{AC}	0 to peak (0.707 V _{RMS})	0 to FS (AC peak)	1 = ON (Other 3 are OFF)	Def.	0 L: Ch 1 to 4 R: Ch 5 to 16	Def.	0 R	0 L	Def.	1 L	0 L: Ch 1 to 4 R: Ch 5 to 16	TBUS
1 to 16	2 V _{AC}	0 to peak (1.414 V _{RMS})	0 to FS (AC peak)	4 = ON (Other 3 are OFF)	Def.	0 R: Ch 1 to 4 L: Ch 5 to 16	Def.	0 R	0 L	Def.	1 L	0 L: Ch 1 to 4 R: Ch 5 to 16	TBUS
1 to 16	4 V _{AC}	0 to peak (3.535 V _{RMS})	0 to FS (AC peak)	3 = ON (Other 3 are OFF)	Def.	0 R: Ch 1 to 4 L: Ch 5 to 16	Def.	0 R	0 L	Def.	1 L	0 L: Ch 1 to 4 R: Ch 5 to 16	TBUS
1 to 16	10 V _{AC}	0 to peak (7.071 V _{RMS})	0 to FS (AC peak)	2 = ON (Other 3 are OFF)	Def.	0 R: Ch 1 to 4 L: Ch 5 to 16	Def.	0 R	0 L	Def.	1 L	0 L: Ch 1 to 4 R: Ch 5 to 16	TBUS
1 to 16	20 V _{AC}	0 to peak (14.142 V _{RMS})	0 to FS (AC peak)	1 = ON (Other 3 are OFF)	Def.	0 R: Ch 1 to 4 L: Ch 5 to 16	Def.	0 R	0 L	Def.	1 L	0 L: Ch 1 to 4 R: Ch 5 to 16	TBUS
1 to 16		Negative GAP range	-FS/2 to +FS/2	X	5 = ON (Other 3 are OFF)	Def.	Def.	0 R	0 L	1 L	0 R	0 L: Ch 1 to 4 R: Ch 5 to 16	TBUS
1 to 16		Positive GAP range	-FS/2 to +FS/2	X	8 = ON (Other 3 are OFF)	Def.	Def.	0 R	0 L	1 L	0 R	0 L: Ch 1 to 4 R: Ch 5 to 16	TBUS

Table 4-7 : IOC 16T switch settings for Vibration signals (AC or AC/DC)

Legend:

L = switch placed to the left

R = switch placed to the right

TBUS = depends on desired Tacho Bus setting

* = maximum input range on the CMS card

Def. = Default switch settings as shown in Figure 4-6

X = setting is unimportant

Available Channels	FSD on CMC 16 (peak value)	Remarks	Output Signal Range ** (FS = 3.5 V _{DC} pk)	SW1 Switches 1 to 4	SW1 Switches 5 to 8	SW2	SW3	SW4	SW5	SW7 Top	SW7 Bottom	SW8	SW9
1 to 16	24 V _{DC}		0 to FS (V _{DC})	Def.	None	Def.	Def.	0 R	0 L	Def.	0 R	0 L: Ch 1 to 4 R: Ch 5 to 16	TBUS
1 to 16	-12 V _{DC} / +12 V _{DC}		0 to FS (V _{DC})	Def.	5 = ON (Other 3 are OFF)	Def.	Def.	0 R	0 L	Def.	0 R	0 L: Ch 1 to 4 R: Ch 5 to 16	TBUS
1 to 16	-12 V _{DC} / +12 V _{DC}			Def.	5 = ON (Other 3 are OFF)	Def.	Def.	0 R	0 L	Def.	0 R	0 L: Ch 1 to 4 R: Ch 5 to 16	TBUS
1 to 16	24 V _{DC}			Def.	None	Def.	Def.	0 R	0 L	Def.	0 R	0 L: Ch 1 to 4 R: Ch 5 to 16	TBUS
1 to 16	-12 V _{DC} / +12 V _{DC}			Def.	5 = ON (Other 3 are OFF)	Def.	Def.	0 R	0 L	Def.	0 R	0 L: Ch 1 to 4 R: Ch 5 to 16	TBUS
1 to 16	-12 V _{DC} / +12 V _{DC}			Def.	5 = ON (Other 3 are OFF)	Def.	Def.	0 R	0 L	Def.	0 R	0 L: Ch 1 to 4 R: Ch 5 to 16	TBUS
1 to 16	24 V _{DC}			Def.	None	Def.	Def.	0 R	0 L	Def.	0 R	0 L: Ch 1 to 4 R: Ch 5 to 16	TBUS
1 to 16	4/20 mA _{DC}	100 Ω measurement resistor. Can also handle AC currents.	4 mA →0 to 20 mA →FS (V _{DC})	Def.	7 = ON (Other 3 are OFF)	Def.	Def.	0 R	0 L	1	0 R	1 R: Ch 1 to 4 L: Ch 5 to 16	TBUS

Table 4-8 : IOC 16T switch settings for Analogue signals

Legend:

R = switch placed to the right

L = switch placed to the left

x -> y = x corresponds to y

** = maximum input range on the CMS card

TBUS = depends on desired Tacho Bus setting

Def. = Default switch settings as shown in Figure 4-6

X = setting is unimportant

Available Channels	FSD on CMC 16 (peak value)	Remarks	Output Signal Range ** (FS = 3.5 V _{DC} pk)	SW1 Switches 1 to 4	SW1 Switches 5 to 8	SW2	SW3	SW4	SW5	SW7 Top	SW7 Bottom	SW8	SW9	SW5 ₃
5 to 16	61.022 mV _{DC}	"K" FS of 800°C corresponds to 54.533% of HW range "E"	0 to +FS (V _{DC})	Def.	Def.	Def.	Def.	1 L	1 R	Def.	1 L	0 R: Ch 5 to 16	Def.	Def.
5 to 16	61.022 mV _{DC}	"J" FS of 800°C corresponds to 74.560% of HW range "E"	0 to +FS (V _{DC})	Def.	Def.	Def.	Def.	1 L	1 R	Def.	1 L	0 R: Ch 5 to 16	Def.	Def.
5 to 16	61.022 mV _{DC}	FSD: 800°C	0 to +FS (V _{DC})	Def.	Def.	Def.	Def.	1 L	1 R	Def.	1 L	0 R: Ch 5 to 16	Def.	Def.
5 to 16	61.022 mV _{DC}	"T" FS of 400°C corresponds to 34.199% of HW range "E"	0 to +FS (V _{DC})	Def.	Def.	Def.	Def.	1 L	1 R	Def.	1 L	0 R: Ch 5 to 16	Def.	Def.
16	-55°C to 150°C		0 to +FS (V _{DC})	Def.	Def.	Def.	Def.	1 L	1 R	Def.	1 L	1 L: Ch 16	Def.	1 L

Table 4-9 : IOC 16T switch settings for Thermocouple signals

Available Channels	FSD on CMC 16 (peak value)	SW7_4 Switches 1 to 4	SW1 Switches 1 to 8	SW2	SW3	SW4	SW8	SW9	Output signal range High > 2.9 V Low < 0.4 V
1 to 4	N/A	Set switch <i>n</i> to "Off" to enable channel <i>n</i> (n = 1, 2, 3 or 4) Other 3 switches must be set to ON	Def.	Def.	Def.	0 R	0 L (Ch 1 to 4)	TACHO signal ON/OFF according to requirements	TTL levels

Table 4-10 : IOC 16T switch settings for Tacho function

Legend:

* = used on Vibro-Meter's System 501X

L = switch placed to the left

N/A = not applicable

** = maximum input range on the CMS card

R = switch placed to the right

Def. = Default switch settings as shown in Figure 4-6

X = setting is unimportant

4.4.5 Elements on the CMC 16

4.4.5.1 CMC 16 Front Panel LED (DIAG)

The CMC 16 card contains a multi-function, multi-colour LED on the front panel. This is used to indicate:

- The status of the card (e.g. card not configured / card working correctly)
- The detection of a communication problem
- The absence of a time synchronization signal

Table 4-11 summarizes the behaviour of the DIAG LED.

Event	DIAG LED Behaviour
<i>No power applied to rack</i>	<i>Off</i>
<i>Normal operation (no failures detected)</i>	<i>Continually GREEN</i>
<i>The CMC 16 is not configured or IOC 16T address mismatch or No IOC 16T detected or DC calibration running</i>	<i>Flashing RED</i>
<i>The CMC 16 is waiting for a time synchronization. After each reset, the CMC 16 waits until it receives the time (in seconds since 1970). No action is undertaken as long as the CMC 16 has no time signal</i>	<i>Flashing YELLOW</i>
<i>The communication is dead. The communication is considered dead when no message has been received for more than 200 seconds.</i>	<i>Flashing GREEN</i>
<i>Programming mode</i>	<i>Alternately RED / GREEN</i>
<i>DC calibration done</i>	<i>Alternately RED / YELLOW</i>

Table 4-11 : Summary of DIAG LED behaviour

4.4.5.2 DIP Switch Package SW19_1

DIP switch package SW19_1 is the only user-adjustable element on the CMC 16 card. Refer to Figure 4-14 for the position and orientation of this component.

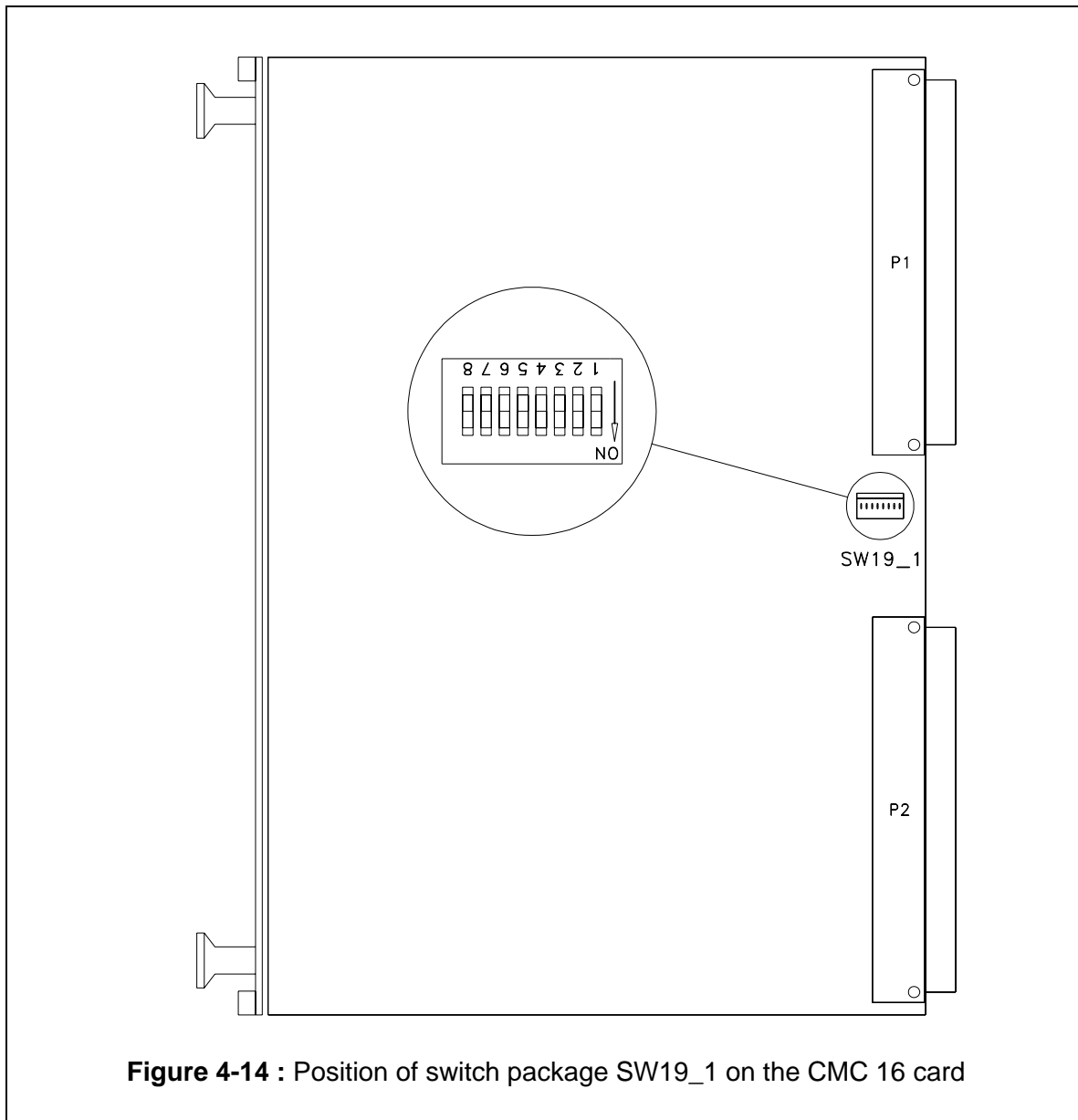
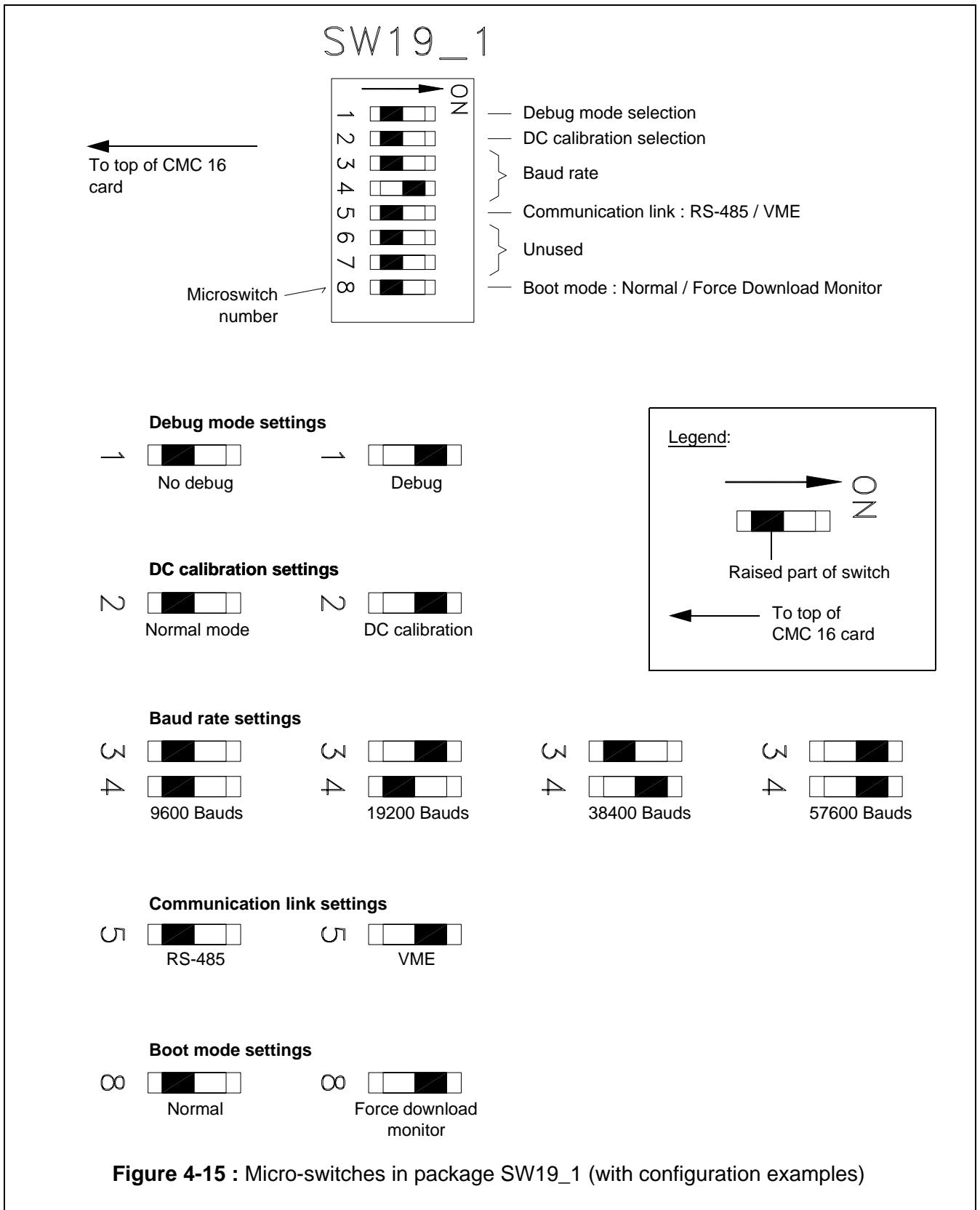

Figure 4-14 : Position of switch package SW19_1 on the CMC 16 card

The micro-switches in package SW19_1 allow various communication parameters and operating modes to be configured. These are summarized, with examples, in Figure 4-15.



4.5 Elements on the CMC 16

4.5.1 CMC 16 Front Panel LED (DIAG)

- The CMC 16 card contains a multi-function, multi-colour LED on the front panel. This is used to indicate:
- The status of the card (e.g. card not configured / card working correctly)
- The detection of a communication problem
- The absence of a time synchronization signal

The table in Figure 4-16 summarizes the behaviour of the DIAG LED.

Event	DIAG LED Behaviour
No power applied to rack	Off
Normal operation (No failures detected)	Continually GREEN
The CMC 16 is not configured or IOC 16T address mismatch or No IOC 16T detected or DC calibration running	Flashing RED
The CMC 16 is waiting for a time synchronization. After each reset, the CMC 16 waits until it receives the time (in seconds since 1970). No action is undertaken as long as the CMC 16 has no time signal	Flashing YELLOW
The communication is dead. The communication is considered dead when no message has been received for more than 200 seconds.	Flashing GREEN
Programming mode	Alternately RED / GREEN
DC calibration done	Alternately RED / YELLOW

Figure 4-16 : Summary of DIAG LED behaviour

4.5.2 DIP Switch Package

The CMC 16 contains only one user-adjustable element: DIP switch package SW19_1. Refer to Figure 4-17 for the position and orientation of this element on the CMC 16 card.

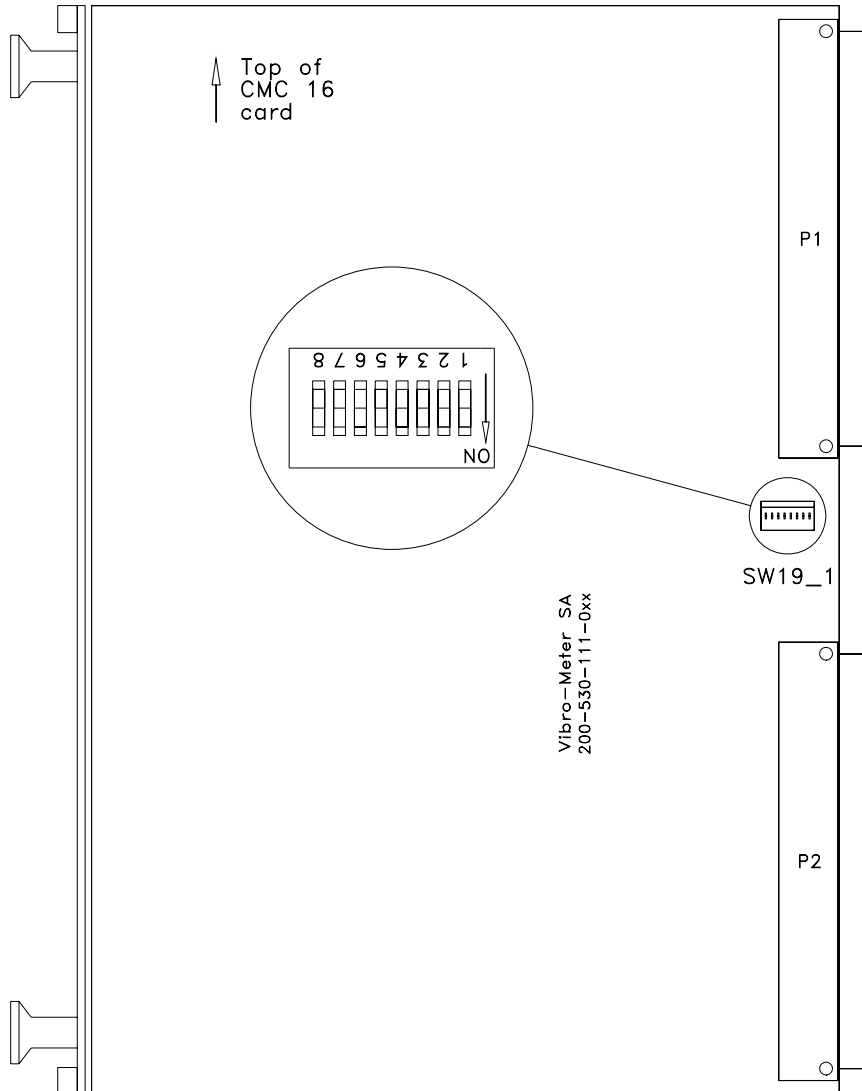

Figure 4-17 : Position of switch package SW19_1 on the CMC 16

The micro-switches in the package SW19_1 allow various communication parameters and operating modes to be configured. These are summarized, with examples, in Figure 4-18.

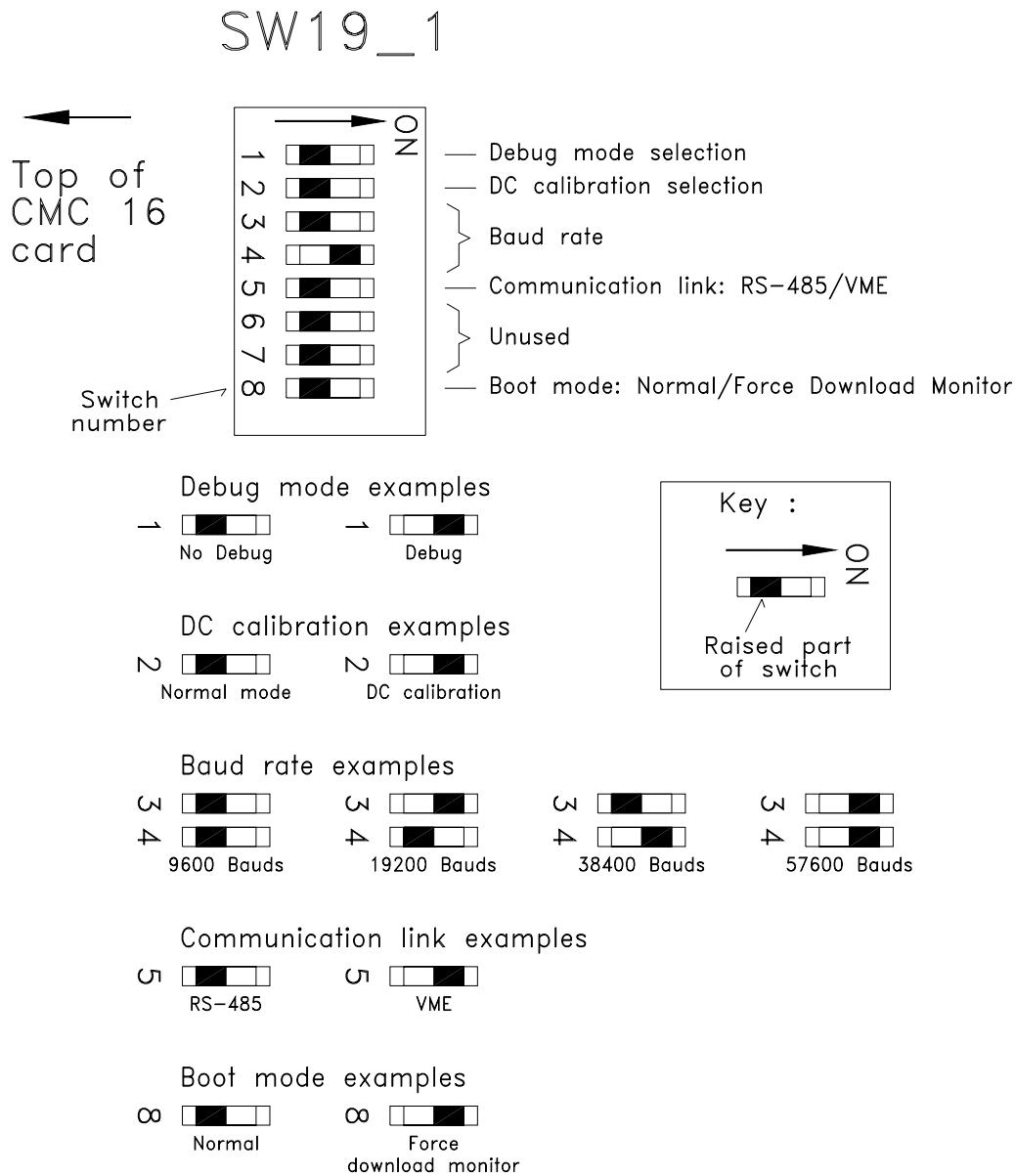

Figure 4-18 : Function of micro-switches in package SW19_1 and configuration examples

A ABBREVIATIONS

The table below defines the abbreviations found in this manual and associated Vibro-Meter documentation.

Abbreviation	Definition
<i>AC</i>	<i>Alternating Current</i>
<i>Amp</i>	<i>Ampere</i>
<i>CCW</i>	<i>Counter-clockwise (anti-clockwise)</i>
<i>cpm</i>	<i>Cycles Per Minute</i>
<i>CMC</i>	<i>Condition Monitoring Card</i>
<i>CMS</i>	<i>Condition Monitoring System</i>
<i>CPU</i>	<i>Central Processing Unit</i>
<i>CSV</i>	<i>Comma Separated Values</i>
<i>CU</i>	<i>Collection Unit</i>
<i>CW</i>	<i>Clockwise</i>
<i>DC</i>	<i>Direct Current</i>
<i>DIP</i>	<i>Dual Inline Package</i>
<i>DSP</i>	<i>Digital Signal Processor</i>
<i>EMI</i>	<i>ElectroMagnetic Interference</i>
<i>FFT</i>	<i>Fast Fourier Transform</i>
<i>FSD</i>	<i>Full Scale Deviation</i>
<i>g</i>	<i>grav (Unit of Acceleration)</i>
<i>HW</i>	<i>Hardware</i>
<i>Hz</i>	<i>Hertz</i>
<i>IEC</i>	<i>International Electrotechnical Commission</i>
<i>IOC</i>	<i>Input / Output Card</i>
<i>ISO</i>	<i>International Standards Organisation</i>
<i>kHz</i>	<i>Kilohertz (10^3 Hertz)</i>
<i>kV</i>	<i>Kilovolt (10^3 Volts)</i>
<i>LAN</i>	<i>Local Area Network</i>
<i>LED</i>	<i>Light Emitting Diode</i>
<i>LP</i>	<i>Low Pressure (Turbine)</i>
<i>mA</i>	<i>Milliamp (10^{-3} Ampere)</i>

Abbreviation	Definition
<i>max.</i>	<i>Maximum</i>
<i>MHz</i>	<i>Megahertz</i>
<i>min.</i>	<i>Minimum</i>
<i>mins</i>	<i>Minutes</i>
<i>MPC</i>	<i>Machinery Protection Card</i>
<i>MPS</i>	<i>Machinery Protection System</i>
<i>MTS</i>	<i>Minimum Tracked Speed</i>
<i>N/A</i>	<i>Not Applicable</i>
<i>OC</i>	<i>Open Collector</i>
<i>Pa</i>	<i>Pascal (SI Unit of Pressure)</i>
<i>PLC</i>	<i>Programmable Logic Controller</i>
<i>pF</i>	<i>Pico Farad (10^{-12} Farad)</i>
<i>P/N</i>	<i>Part Number</i>
<i>ppm</i>	<i>Parts Per Million</i>
<i>psi</i>	<i>Pounds per Square Inch</i>
<i>RAM</i>	<i>Random Access Memory</i>
<i>RLC</i>	<i>Relay Card</i>
<i>RMS</i>	<i>Root Mean Square</i>
<i>ROM</i>	<i>Read Only Memory</i>
<i>RPM</i>	<i>Revolutions Per Minute</i>
<i>RTU</i>	<i>Remote Terminal Unit</i>
<i>T_s</i>	<i>Sampling Duration</i>
<i>TTL</i>	<i>Transistor-Transistor Logic</i>
<i>V</i>	<i>Volts</i>
<i>V_{AC}</i>	<i>Voltage, Alternating Current</i>
<i>V_{DC}</i>	<i>Voltage, Direct Current</i>
<i>VM600</i>	<i>Vibro-Meter's VM600 Series (Machinery Protection Systems and Condition and Performance Monitoring Systems)</i>
<i>VME</i>	<i>Versa Module Eurocard</i>

Please use this space for any additional information: "

DOCUMENT EVALUATION FORM

Vibro-Meter welcomes your evaluation of this document. Your comments and suggestions help us improve the quality of our documentation.

Document Title CMS Software Hardware Manual :

Reference : MACMS-HW/E

Edition : Edition 3

Date of Issue : Mar 31/06

Circle **Yes** or **No** to answer the following questions:

- | | | |
|--|------------|-----------|
| • Is the document well organized? | Yes | No |
| • Is the information technically accurate? | Yes | No |
| • Would you like more technical detail? | Yes | No |
| • Are the instructions clear and complete? | Yes | No |
| • Are the descriptions easy to understand? | Yes | No |
| • Are the examples and diagrams/photos helpful? | Yes | No |
| • Are there enough examples and diagrams/photos? | Yes | No |
| • Is the style/wording easy to read? | Yes | No |
| • Is any information not included? (please list in "Comments" below) | Yes | No |

Comments

(Please continue on back of sheet if necessary)

Contact Details: You or the designated Contact Person for your company:

Name _____ Job Title _____

Company _____ Email _____

Address _____

Signature _____ Date _____

Please mail, email or fax this document evaluation form to:

Technical Publications

Vibro-Meter SA

Route de Moncor 4

1701 Fribourg, Switzerland

web: www.vibro-meter.com , email: techpubs.ch@vibro-meter.com, Fax: +41 (0)26 407 15 55

Please use this space for any additional comments: