

Servo Motors & Drives



► Brushless Servo Motors



154

IM Motors

High torque and efficiency in a compact rugged package

168

Two Wire Brushless Motors

Patented technology makes it easy to upgrade to brushless from brush motor, utilizing existing drive electronics

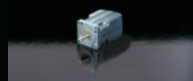

170

Frameless Brushless Servo Motors

High performance with reduced mechanical complexity for customized solutions



► Brushless Digital Drive / Control



180

i-Drive

Chip on Chip technology for high power in small package, configurable for torque, velocity and indexing mode

Table of Contents



= Brushless Servo Motors

154

IM Brushless Servo Motors

168

Two-Wire Brushless Servo Motors

170

Frameless Brushless Servo Motors



= Brushless Digital Drive/Control

180

i-Drive Servo Drive Amplifier

194

Motor and Drive Selection



= Engineering Reference

294

Frameless
Application & Installation

304

Servo Motor & Drive
Theory of Operation

► Motors & Drives: Application Solutions

Frameless Motors used in Auger Fillers

APPLICATION CHALLENGE

The customer, Per-Fil, manufactures an auger filler machine that uses a fluted screw to volumetrically fill a container. The standard framed servomotor was mounted to the screw using a mechanical coupling device, gearbox and timing belt, but this proved unable to provide the performance required in a space efficient package. When engineers were looking to improve their machine design, the issues they faced were:

Large package size

The motor, together with all the mechanical coupling and reduction devices, took up a lot of space on the machine.

Overtorque and Runout

The timing belts used in this application created a condition of overtorque and runout, which caused the auger screw to rub the side of the funnel.

Reduced System Reliability

These mechanical devices created reliability issues, causing down time and tolerance problems.



Two-Wire Module in a Medical Application

APPLICATION CHALLENGE

When a supplier stopped making the custom DC brush motors used for medical centrifuges, the manufacturer of these custom laboratory products was faced with a pressing challenge. With thousands of installed units worldwide, they had to find a new motor for both field replacement and new production. But without enough time to redesign the machine, the controls, or rewrite the software, the company needed a fast solution, their challenges were:

Form Factor

The unit had to mount in the existing volumetric space.

Electrical

The unit had to operate off a standard SCR generated DC bus

Controls

The unit needed to be compatible with existing controls



Special Design Servo Motor for Automotive Application

APPLICATION CHALLENGE

A major US manufacturer of vehicles was developing a new car powered by electric motors. Since the car had no gas powered engine to drive the power assist steering alternate methods were required. Mechanical gearing was ruled out due to space requirements and standard electric motors would drain the batteries of the vehicle too quickly. The company had a problem and needed a unique cost effective solution. The opportunity was as follows:

Reduced Package Size

The unit needed to provide the torque with an effective weight to space ratio

Rugged Design

The motor had to operate in stringent "under the hood" conditions



BAYSIDE SOLUTION

(1) Frameless Brushless Motor

- ▶ The design problems were solved using a frameless kit motor integrated into the auger drive assembly. This allowed the manufacturer to build a single-shaft system eliminating the problems that existed before. Fewer parts were needed in the design, eliminating the couplings and bearings in the auger assembly. This increased reliability, allowed for higher speeds, accuracy and stiffness.
- ▶ Without couplings, timing belts and gearboxes, the customer was able to create a much more compact design.
- ▶ Due to increased reliability, down-time no longer becomes a critical issue for users.
- ▶ This solution can be used in packaging applications in the following industries:
 1. Consumer products
 2. Food Processing
 3. Medical/Pharmaceutical



BAYSIDE SOLUTION

(1) TW42 Two-Wire Module

- ▶ Bayside's Two-Wire Module let the customer replace a brush motor with a brushless motor, yet control it with the centrifuge's existing SCR full-wave bridge controller. The module, an electronic commutation device, takes the motor and hall wires from a brushless DC motor and provides two input wires that marry with a brush-type amplifier. It consists of a signal responsive stator-coil switch circuit, commutation logic, direction-polarity control circuit, and an auxiliary DC power supply. Full four-quadrant operation provides torque control through zero speed without any deadband.
- ▶ The replacement motor and module fit into the existing holes in the centrifuge, making redesign unnecessary and field replacement easy.
- ▶ By removing brush contact, brushless motors provide longer life with lower operating temperatures.
- ▶ By replacing the brush motor with a brushless servo, the customer eliminated brush dust, which is especially harmful in medical and biotech applications.
- ▶ This solution can be used in applications in the following industries:
 1. Automotive
 2. Medical/Biotech
 3. Pharmaceutical
 4. Semiconductor



Servo Motors
& Drives

BAYSIDE SOLUTION

(1) Custom designed brushless steering pump motor.

- ▶ Bayside engineering collaborated with the auto maker and it's pump manufacturer and presented many various options. The final solution was a custom designed high efficiency motor directly driving the pump. The front mounting flange mated to the pump surface and formed the back end housing of the pump. A zero porosity surface was therefore required for proper sealing. The housing was designed from an extrusion to minimize cost and maximize yield and was formed to plug into a unique low profile drive/controller design. The stator was custom designed to operate at it's highest efficiency point on a 48 volt DC bus.
- ▶ The solution was designed using (FEMA) "Failure effect mode analysis" methodology and put into manufacturing in record time.
- ▶ The efficiency of the motor assisted in providing maximum battery life for the vehicle
- ▶ The motor was brushless and therefore required no maintenance.
- ▶ The motor was designed to configurable for standard gas vehicles.





► **IM Series:** **Brushless Servo Motors**

Brushless Servo Motors for factory automation applications. Bayside's IM Series brushless servo motors provide exceptional torque and efficiency in a compact, rugged package. The IM Series incorporates a high-density skewed copper winding and neodymium magnets for the maximum torque per frame size and minimum cogging. Designed to optimize the thermal path, the aluminum housing provides low operating temperatures and high efficiency.



IM Series: "Sine"



SINE Performance Specifications

Frame Size	Winding (1) C = 110 Vac (160 Vdc Bus) D = 208 Vac (300 Vdc Bus) E = 460 Vac (660 Vdc Bus)	Power		Max. Operating Speed (RPM)	Continuous Rated Speed (RPM)	Continuous Rated Torque @ Rated Speed		Peak Torque T_P		Continuous Stall Torque T_C		Peak Current I_P (amps)	Cont. Current I_C (amps)
		(Hp)	(Kwatts)			(Nm)	(in lb)	(Nm)	(in lb)	(Nm)	(in lb)		
IM60 -1	C	0.28	0.21	5,404	4,100	0.49	4.38	1.64	14.67	0.55	4.89	4.81	1.60
IM60 -1	D	0.27	0.20	5,003	3,750	0.50	4.50	1.64	14.67	0.55	4.89	2.38	0.79
IM60-2	C	0.50	0.37	5,404	4,600	0.77	6.88	2.59	23.17	0.86	7.72	7.60	2.53
IM60-2	D	0.47	0.35	5,066	4,300	0.77	6.88	2.59	23.17	0.86	7.72	3.80	1.27
IM90-1	C	1.03	0.77	4,678	4,000	1.82	16.25	5.54	49.49	1.85	16.50	14.06	4.69
IM90-1	D	0.94	0.70	4,386	3,650	1.82	16.25	5.54	49.49	1.85	16.50	7.03	2.34
IM90-1	E	0.98	0.73	4,825	4,100	1.68	15.00	5.54	49.49	1.85	16.50	3.51	1.17
IM90-2	C	1.21	0.90	3,599	3,200	2.66	23.75	8.84	78.94	2.95	26.31	17.25	5.75
IM90-2	D	1.12	0.83	3,509	3,000	2.63	23.44	8.84	78.94	2.95	26.31	8.97	2.99
IM90-2	E	1.30	0.97	4,178	3,750	2.45	21.88	8.84	78.94	2.95	26.31	4.85	1.62
IM115-1	C	1.70	1.27	3,499	2,850	4.20	37.50	13.90	124.06	4.63	41.35	26.36	8.79
IM115-1	D	1.64	1.22	3,412	2,750	4.20	37.50	13.90	124.06	4.63	41.35	13.71	4.57
IM115-1	E	1.96	1.46	4,012	3,400	4.06	36.25	13.90	124.06	4.63	41.35	7.33	2.44
IM115-2	C	2.24	1.67	2,843	2,400	6.58	58.75	22.25	198.68	7.42	66.23	41.84	13.95
IM115-2	D	2.53	1.89	3,280	2,900	6.16	55.00	22.25	198.68	7.42	66.23	21.10	7.03
IM115-2	E	2.66	1.98	3,753	3,350	5.60	50.00	22.25	198.68	7.42	66.23	10.97	3.66
IM142-3	D	4.37	3.26	4,644	4,400	7.00	62.50	42.77	381.88	14.26	127.29	57.43	19.14
IM142-3	E	4.17	3.11	3,269	2,800	10.50	93.75	42.77	381.88	14.26	127.29	18.38	6.13
IM142-4	D	3.66	2.73	3,096	2,950	8.75	78.13	67.24	600.35	22.41	200.12	60.19	20.06
IM142-4	E	4.37	3.26	2,858	2,750	11.20	100	67.24	600.35	22.41	200.12	27.78	9.26

Frame Size	Motor Constant K_m		Torque (2) Constant K_{T-L-L}		Voltage (2) Constant K_{E-L-L} (V/kRPM)	Resistance R_{L-L} (ohms)	Inductance L_{L-L} (mH)	Core Loss Watts @ 1k RPM	Thermal Resistance θ ($^{\circ}C/W$)	Pole Count #	Electrical Time Constant (m sec)	Mechanical Time Constant (m sec)
	(Nm/ \sqrt{W})	(in lb/ \sqrt{W})	(Nm/amp)	(in lb/amp)								
IM60 -1	0.08	0.73	0.34	3.05	29.61	11.9	12.9	1	1.93	6	1.1	1.5
IM60 -1	0.08	0.73	0.69	6.17	59.96	48.7	52.9	1	1.93	6	1.1	1.5
IM60-2	0.13	1.15	0.34	3.05	29.61	4.8	6.5	1	1.93	6	1.3	0.93
IM60-2	0.13	1.15	0.68	6.10	59.22	19.1	25.8	1	1.93	6	1.3	0.93
IM90-1	0.20	1.82	0.39	3.52	34.20	2.6	4.6	2	1.06	8	1.8	1.4
IM90-1	0.20	1.82	0.79	7.04	68.40	10.2	18.3	2	1.06	8	1.8	1.4
IM90-1	0.20	1.82	1.58	14.08	136.80	41.1	73.2	2	1.06	8	1.8	1.4
IM90-2	0.33	2.91	0.51	4.58	44.46	1.6	3.9	5	1.06	8	2.4	0.67
IM90-2	0.33	2.91	0.99	8.80	85.50	6.3	14.3	5	1.06	8	2.4	0.67
IM90-2	0.33	2.91	1.82	16.26	157.97	21.5	48.8	5	1.06	8	2.4	0.67
IM115-1	0.39	3.47	0.53	4.71	45.73	1.2	2.9	7	0.61	12	2.4	1.5
IM115-1	0.39	3.47	1.01	9.05	87.94	4.7	11.9	7	0.61	12	2.4	1.5
IM115-1	0.39	3.47	1.90	16.93	164.50	16.1	38.1	7	0.61	12	2.4	1.5
IM115-2	0.62	5.56	0.53	4.75	56.28	0.73	2.2	13	0.61	12	3	1.1
IM115-2	0.62	5.56	1.05	9.41	91.46	1.9	5.9	13	0.61	12	3	1.1
IM115-2	0.62	5.56	2.03	18.10	175.88	7.3	21.8	13	0.61	12	3	1.1
IM142-3	1.03	9.17	0.74	6.65	64.60	0.35	2.2	24	0.45	12	6	1.2
IM142-3	1.03	9.17	2.33	20.78	201.88	3.9	21.5	24	0.45	12	6	1.2
IM142-4	1.62	14.42	1.12	9.97	96.90	0.34	2.5	48	0.45	12	6.8	0.9
IM142-4	1.62	14.42	2.42	21.61	209.95	1.5	11.6	48	0.45	12	6.8	0.9

(1) All C & D windings can be operated at alternate bus voltages up to 500 Vdc (Bus). The no load speed will vary proportionally with the change in voltage.

(2) Peak of sine wave

* For Motor Selection calculations see page 194



IM Series: "Trap"

TRAP Performance Specifications

Frame Size	Winding (1) C = 110 Vac (160 Vdc Bus) D = 208 Vac (300 Vdc Bus) E = 460 Vac (660 Vdc Bus)	Power		Max. Operating Speed (RPM)	Continuous Rated Speed (RPM)	Continuous Rated Torque @ Rated Speed		Peak Torque T _P		Continuous Stall Torque T _C		Peak Current I _P (amps)	Cont. Current I _C (amps)
		(Hp)	(Kwatts)			(Nm)	(in lb)	(Nm)	(in lb)	(Nm)	(in lb)		
IM60 -1	C	0.28	0.21	5,404	4,100	0.49	4.38	1.64	14.67	0.55	4.89	6	1.96
IM60 -1	D	0.27	0.20	5,003	3,750	0.50	4.50	1.64	14.67	0.55	4.89	3	0.97
IM60-2	C	0.50	0.37	5,404	4,600	0.77	6.88	2.59	23.17	0.86	7.72	9	3.09
IM60-2	D	0.47	0.35	5,066	4,300	0.77	6.88	2.59	23.17	0.86	7.72	5	1.55
IM90-1	C	1.03	0.77	4,678	4,000	1.82	16.3	5.54	49.49	1.85	16.5	17	5.72
IM90-1	D	0.94	0.70	4,386	3,650	1.82	16.3	5.54	49.49	1.85	16.5	9	2.86
IM90-1	E	0.98	0.73	4,825	4,100	1.68	15.0	5.54	49.49	1.85	16.5	4	1.43
IM90-2	C	1.21	0.90	3,599	3,200	2.66	23.8	8.84	78.94	2.95	26.3	21	7.01
IM90-2	D	1.12	0.83	3,509	3,000	2.63	23.4	8.84	78.94	2.95	26.3	11	3.65
IM90-2	E	1.30	0.97	4,178	3,750	2.45	21.9	8.84	78.94	2.95	26.3	6	1.97
IM115-1	C	1.70	1.27	3,499	2,850	4.20	37.5	13.9	124.1	4.63	41.4	32	10.7
IM115-1	D	1.64	1.22	3,412	2,750	4.20	37.5	13.9	124.1	4.63	41.4	17	5.57
IM115-1	E	1.96	1.46	4,012	3,400	4.06	36.3	13.9	124.1	4.63	41.4	9	2.98
IM115-2	C	2.24	1.67	2,843	2,400	6.58	58.8	22.3	198.7	7.42	66.2	42	13.9
IM115-2	D	2.53	1.89	3,280	2,900	6.16	55.0	22.3	198.7	7.42	66.2	26	8.58
IM115-2	E	2.66	1.98	3,753	3,350	5.60	50.0	22.3	198.7	7.42	66.2	13	4.46
IM142-3	D	4.37	3.26	4,644	4,400	7.00	62.5	42.8	381.9	14.26	127	70	23.4
IM142-3	E	4.17	3.11	3,269	2,800	10.5	93.8	42.8	381.9	14.26	127	22	7.47
IM142-4	D	3.66	2.73	3,096	2,950	8.75	78.1	67.2	600.3	22.41	200	73	24.5
IM142-4	E	4.37	3.26	2,858	2,750	11.2	100	67.2	600.3	22.41	200	34	11.3

Frame Size	Motor Constant K _m		Torque (2) Constant K _{T L-L}		Voltage (2) Constant K _{E L-L}		Resistance R _{L-L} (ohms)	Inductance L _{L-L} (mH)	Core Loss Watts @ 1k RPM	Thermal Resistance θ (°C/W)	Pole Count #	Electrical Time Constant (m sec)	Mechanical Time Constant (m sec)
	(Nm/√W)	(in lb/√W)	(Nm/amp)	(in lb/amp)	(V/KRPM)								
IM60 -1	0.08	0.73	0.28	2.50	29.6	11.9	12.9	1	1.93	6	1.1	1.5	
IM60 -1	0.08	0.73	0.57	5.06	60.0	48.7	52.9	1	1.93	6	1.1	1.5	
IM60-2	0.13	1.15	0.28	2.50	29.6	4.8	6.5	1	1.93	6	1.3	0.93	
IM60-2	0.13	1.15	0.56	5.00	59.2	19.1	25.8	1	1.93	6	1.3	0.93	
IM90-1	0.20	1.82	0.32	2.89	34.2	2.6	4.6	2	1.06	8	1.8	1.4	
IM90-1	0.20	1.82	0.65	5.77	68.4	10.2	18.3	2	1.06	8	1.8	1.4	
IM90-1	0.20	1.82	1.29	11.5	137	41.1	73.2	2	1.06	8	1.8	1.4	
IM90-2	0.33	2.91	0.42	3.75	44.5	1.6	3.9	5	1.06	8	2.4	0.67	
IM90-2	0.33	2.91	0.81	7.21	85.5	6.3	14.3	5	1.06	8	2.4	0.67	
IM90-2	0.33	2.91	1.49	13.3	158	21.5	48.8	5	1.06	8	2.4	0.67	
IM115-1	0.39	3.47	0.43	3.86	45.7	1.2	2.9	7	0.61	12	2.4	1.5	
IM115-1	0.39	3.47	0.83	7.42	87.9	4.7	11.9	7	0.61	12	2.4	1.5	
IM115-1	0.39	3.47	1.55	13.9	165	16.1	38.1	7	0.61	12	2.4	1.5	
IM115-2	0.62	5.56	0.53	4.75	56.3	0.73	2.2	13	0.61	12	3	1.1	
IM115-2	0.62	5.56	0.86	7.72	91.5	1.9	5.9	13	0.61	12	3	1.1	
IM115-2	0.62	5.56	1.66	14.8	176	7.3	21.8	13	0.61	12	3	1.1	
IM142-3	1.03	9.17	0.61	5.45	64.6	0.35	2.2	24	0.45	12	6	1.2	
IM142-3	1.03	9.17	1.91	17.0	202	3.9	21.5	24	0.45	12	6	1.2	
IM142-4	1.62	14.4	0.92	8.18	96.9	0.34	2.5	48	0.45	12	6.8	0.9	
IM142-4	1.62	14.4	1.98	17.7	210	1.5	11.6	48	0.45	12	6.8	0.9	

(1) All C & D windings can be operated at alternate bus voltages up to 500 Vdc (Bus). The no load speed will vary proportionally with the change in voltage.

(2) Peak of sine wave

* For Motor Selection calculations see page 194

IM Series: Brushless Servo Motors



Weight

Frame Size	Stack Length	Without Brake		With Brake	
		(kg)	(lb)	(kg)	(lb)
IM060	1	1.5	3.3	1.8	3.9
IM060	1	1.5	3.3	1.8	3.9
IM060	2	2.1	4.6	2.4	5.3
IM060	2	2.1	4.6	2.4	5.3
IM090	1	3.5	7.7	4.3	9.5
IM090	1	3.5	7.7	4.3	9.5
IM090	2	4.8	10.6	5.6	12.4
IM090	2	4.8	10.6	5.6	12.4
IM115	1	4.7	10.4	5.7	12.6
IM115	1	4.7	10.4	5.7	12.6
IM115	2	5.6	12.4	6.9	15.2
IM115	2	5.6	12.4	6.9	15.2
IM142	3	14.8	32.6	18.6	41
IM142	4	22	48.5	25.8	56.9

Inertia

Frame Size	Stack Length	Without Brake		With Brake	
		(gm cm sec ²)	(oz in sec ²)	(gm cm sec ²)	(oz in sec ²)
IM060	1	0.093	0.0013	0.1217	0.0017
IM060	1	0.093	0.0013	0.1217	0.0017
IM060	2	0.149	0.0021	0.1777	0.0025
IM060	2	0.149	0.0021	0.1777	0.0025
IM090	1	0.558	0.0078	0.7307	0.0102
IM090	1	0.558	0.0078	0.7307	0.0102
IM090	2	0.71	0.0099	0.8827	0.0123
IM090	2	0.71	0.0099	0.8827	0.0123
IM115	1	2.37	0.0329	2.8451	0.0395
IM115	1	2.37	0.0329	2.8451	0.0395
IM115	2	4.28	0.059	4.7551	0.656
IM115	2	4.28	0.059	4.7551	0.656
IM142	3	11.8	0.164	12.2751	0.1706
IM142	4	22.8	0.317	23.2751	0.3236

Encoder Specifications (All IM Frame Sizes)

2000 Line Rotary Encoder	8,000 counts/rev Post Quadrature
Electrical Input	5 Vdc, 125 ma maximum (plus interface loads)
Encoder Output	A, B, I, \bar{A} , \bar{B} , \bar{I} Square wave, Diff. Frequency Response 250 KHz with commutation

Resolver Specification (All IM Frame Sizes)

Frequency	Hz	5,000
Input Voltage	Vrms	4.0
Input Current	ma max.	23
Input Power	Watts nom.	0.045
Transformation Ratio	± 10%	0.50
Output Voltage	Vrms	2.0
Sensitivity	mv / Deg	35

Brake Specification

Frame Size	Static Holding Torque		Voltage (V)	Current (amps)	Resistance (ohms)	Inertia	
	(Nm)	(in lb)				(gm cm sec ²)	(oz in sec ²)
IM060	1.3	10	24 Vdc	0.21	113	0.0287	0.0004
IM090	7.6	67	24 Vdc	0.72	33.4	0.1727	0.0024
IM115	27	240	24 Vdc	0.88	27.3	0.4751	0.0066
IM142	27	240	24 Vdc	0.88	27.3	0.4751	0.0066



▶ **IM** Brushless Servo Motors: High Performance Compact Design

When to Use:

- ▶ Low cogging for smooth operation
- ▶ Low inertia for high acceleration
- ▶ Metric or NEMA mounting
- ▶ IP65
- ▶ UL rating

Applications:

- ▶ Automotive
- ▶ Machine Tool
- ▶ Material Handling
- ▶ Medical
- ▶ Packaging
- ▶ Paper Converting
- ▶ Robotics
- ▶ Semiconductor

All IM Series motors carry a CE and UL rating and are well suited to a wide range of applications. IM Series motors are completely sealed with IP65 rating. They allow for easy integration with amplifiers and servo control and feature standard power and sensor DIN-Type connectors. Oversized output bearings provide high capacity and ruggedness for your most demanding servo applications.

2

**IP65 Sealing with
Viton Seals and O-Rings**
for use in harsh environments.

3

**MS or DIN-Type Right
Angle Swivel Connectors**
for maximum mounting flexibility.

1

Large Output Bearings
for high radial loads and longer motor life.

2

1

7

8

Anodized Aluminum Housing
for maximum corrosion protection, easy washdown capability and optimized thermal characteristics combined to provide long life at peak outputs.

7

Optional Brake
for holding position either in power-off safety mode or power-on holding mode.

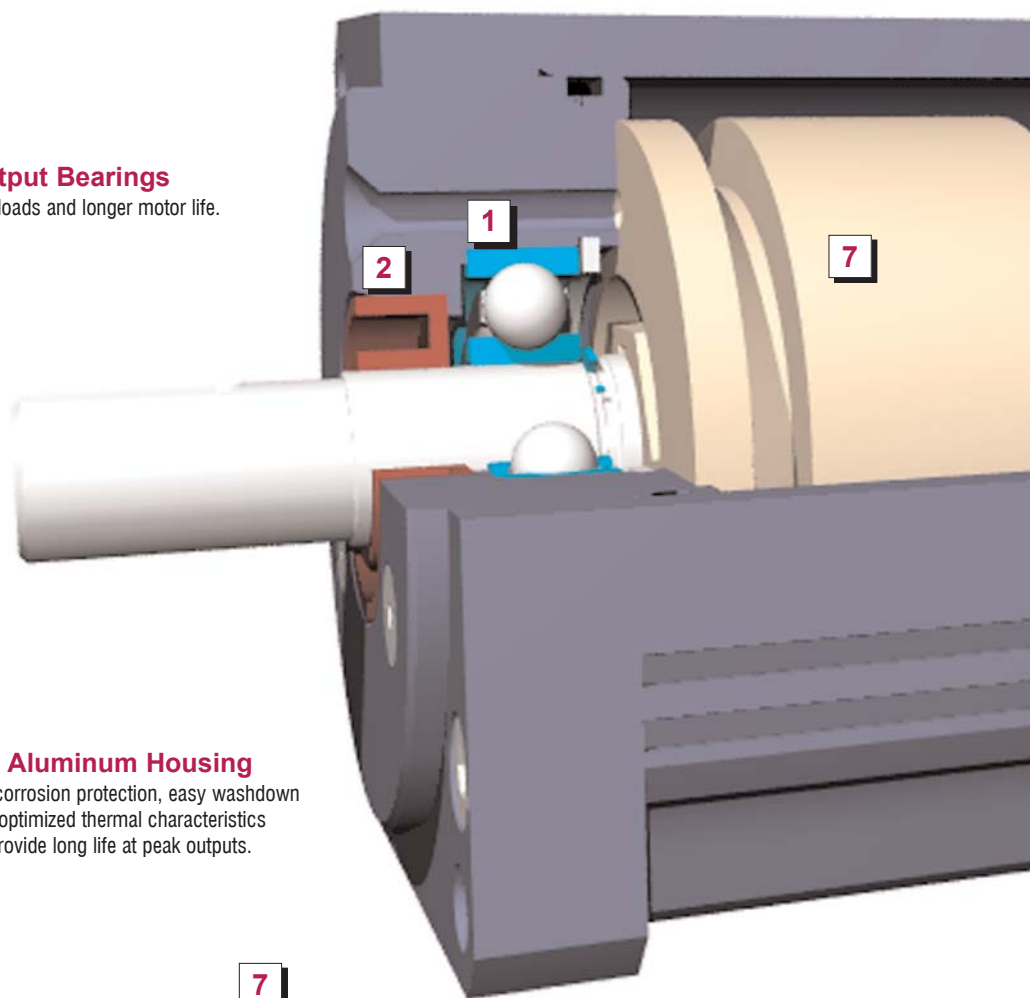



High Performance Motor in a Compact Design.

It provides design flexibility with the low inertia for a high acceleration, low cogging for smooth operation and encoder or resolver feedback. The oversize bearings, one piece housing construction and industrial grade connectors provide for a rugged assembly.

4

High Density Copper Windings and Rare-Earth Magnets

for maximum torque and efficiency high slot fill and formed end-turns optimizes power output per frame size.

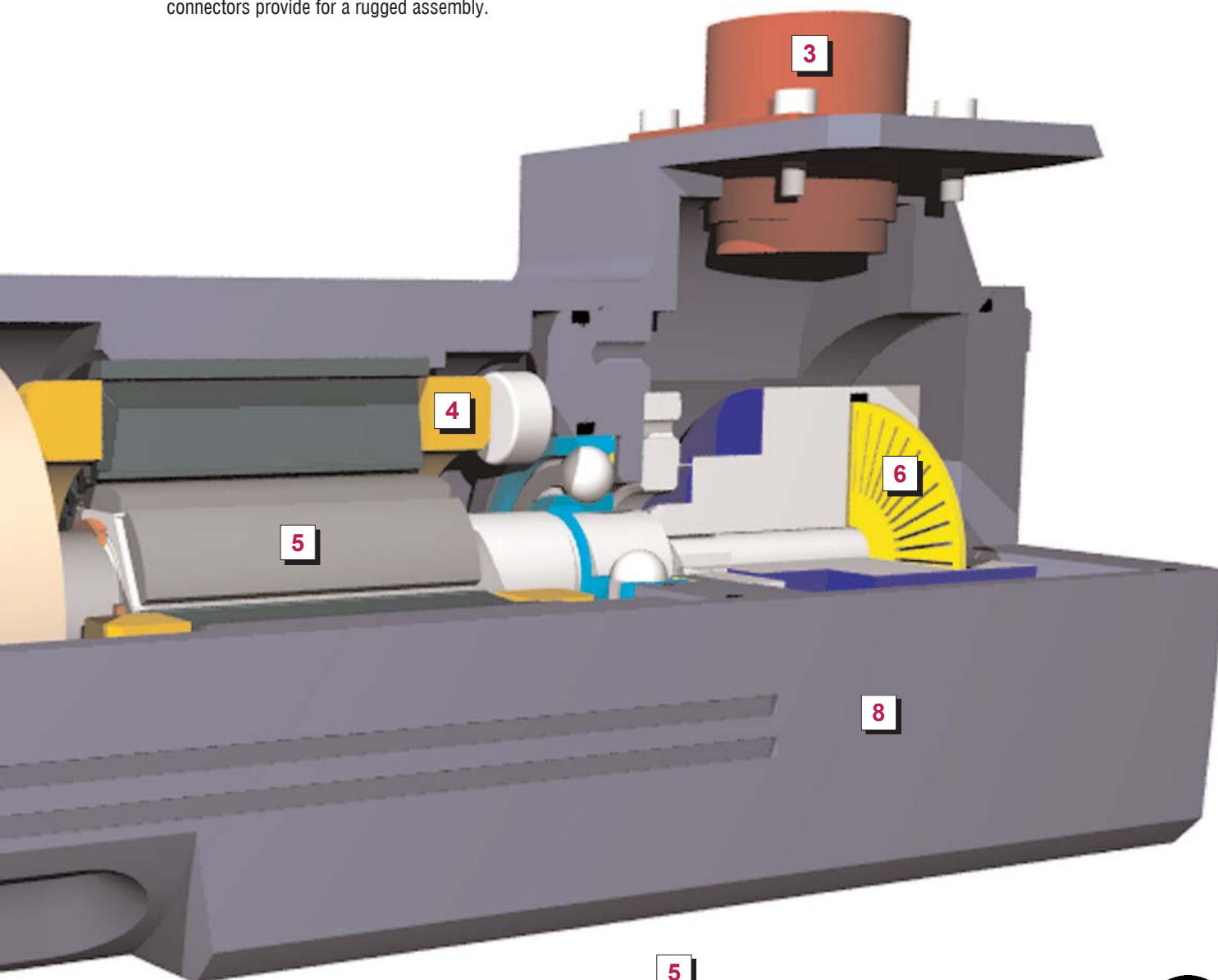

Servo Motors & Drives

6

Encoder Or Optional Resolver

in same package for accurate position and velocity feedback pre-wired and connector terminated.

5

Skewed Laminations with Odd Slot Counts

for reduced cogging providing ultra smooth motion. Less torque ripple even at slow speeds.





IM Series: IM060 & IM090 Speed / Torque Curves

IM060
Single Stack

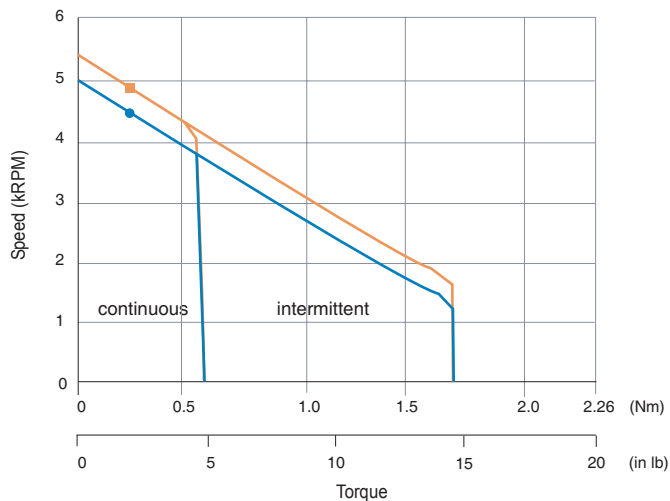

IM090
Single Stack

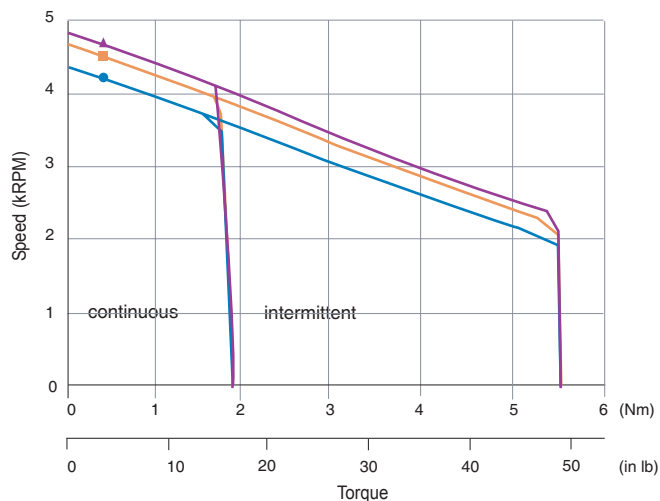

160 Vdc —■— 300 Vdc —●— 660 Vdc —▲—

IM060
Double Stack

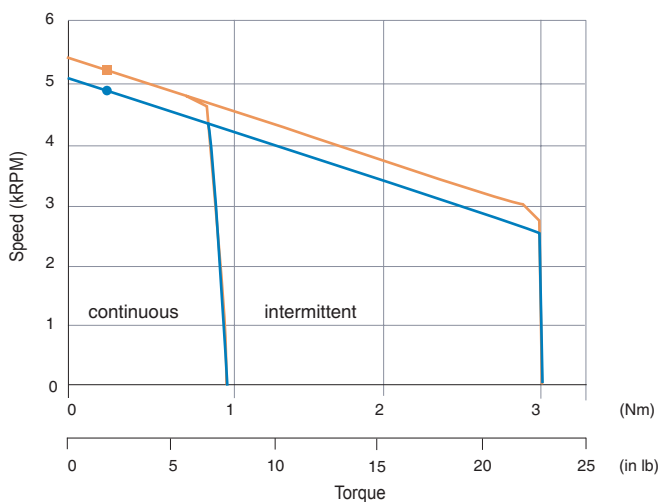

IM090
Double Stack

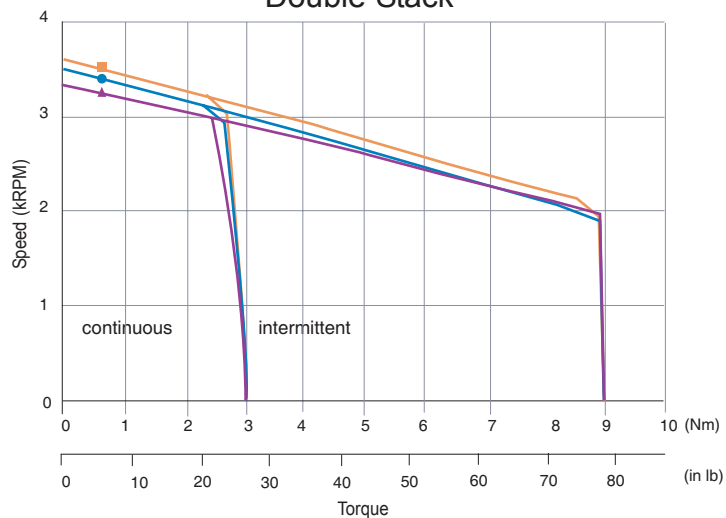

IM60
Continuous rated stall torque is with motor mounted on a 203mm x 203mm x 13mm (8in x 8in x 0.5in) aluminum plate in a 25°C ambient, with the winding at 155°C.

IM90
Continuous rated stall torque is with motor mounted on a 254mm x 254mm x 13mm (10in x 10in x 0.5in) aluminum plate in a 25°C ambient, with the winding at 155°C.

IM Series: IM115 & IM142 Speed / Torque Curves



IM115
Single Stack

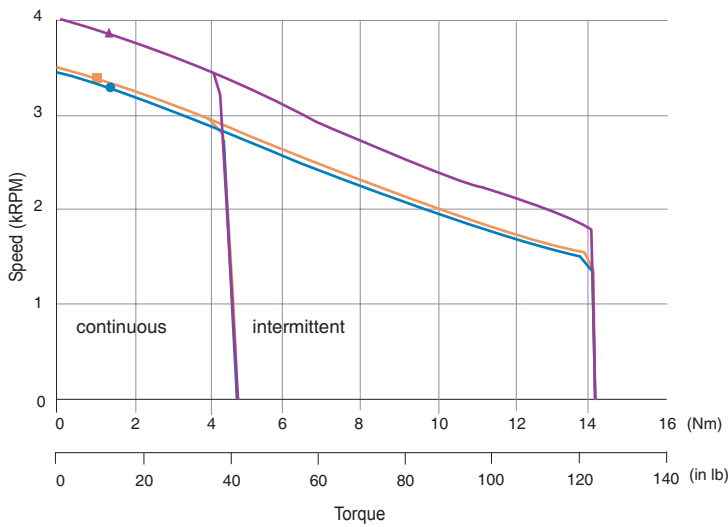

IM142
Single Stack

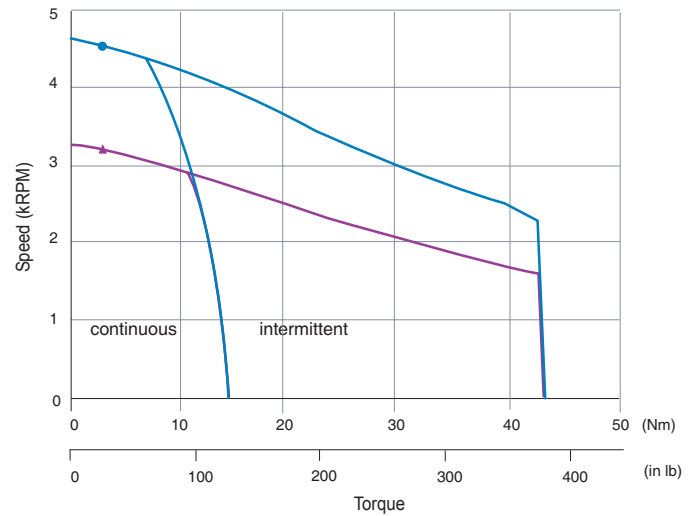

160 Vdc —■— 300 Vdc —●— 660 Vdc —▲—

IM115
Double Stack

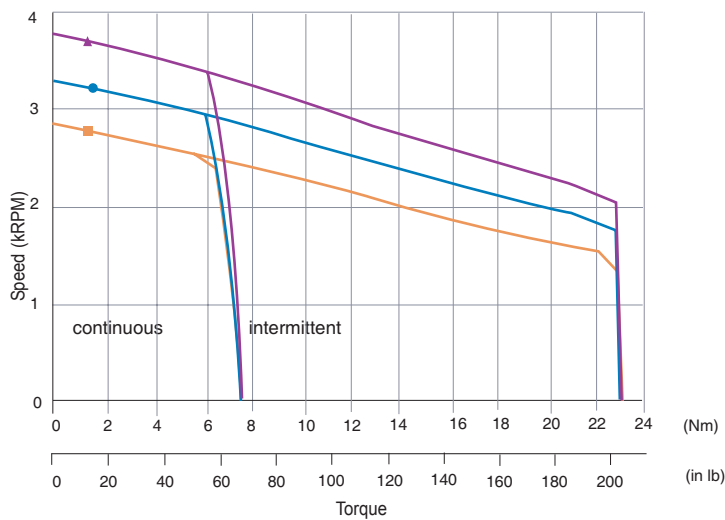

IM142
Double Stack

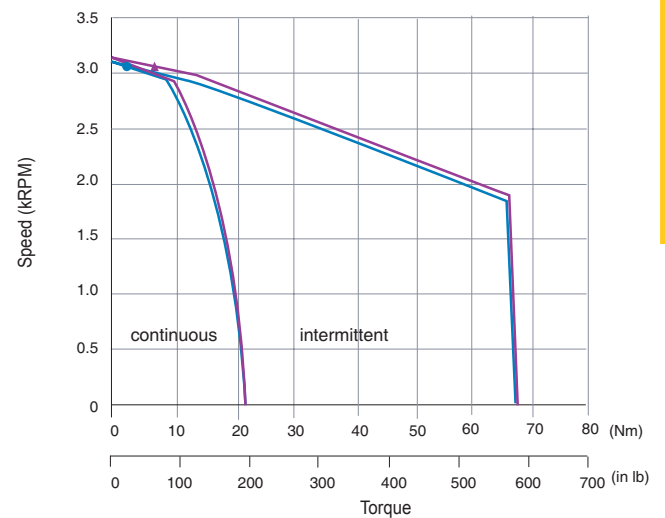

IM115
Continuous rated stall torque is with motor mounted on a 305mm x 305mm x 13mm (12in x 12in x 0.5in) aluminum plate in a 25°C ambient, with the winding at 155°C.

IM142
Continuous rated stall torque is with motor mounted on a 381mm x 381mm x 13mm (15in x 15in x 0.5in) aluminum plate in a 25°C ambient, with the winding at 155°C.



IM Series: Brushless Servo Motors

Dimensions

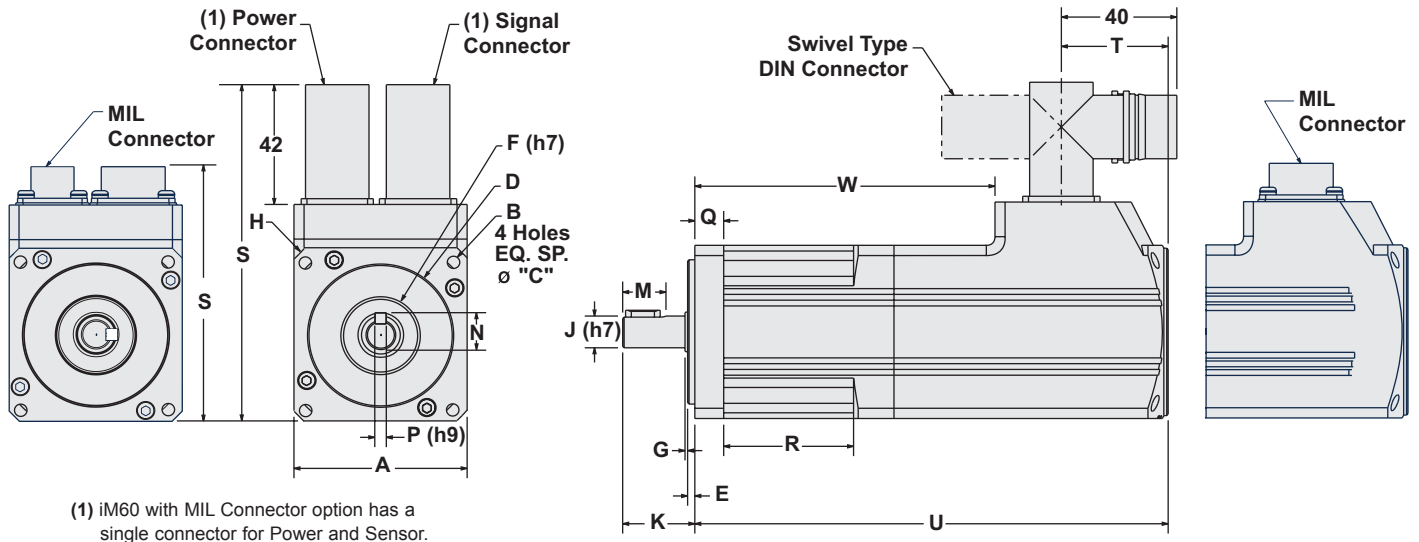

METRIC SIZES

Frame Size	A Square Flange		B Bolt Hole		C Bolt Circle Diameter		D Pilot Diameter		E Pilot Thickness		F Shoulder Diameter		G Shoulder Height		H Housing Diameter	
	(mm)	(in)	(mm)	(in)	(mm)	(in)	(mm)	(in)	(mm)	(in)	(mm)	(in)	(mm)	(in)	(mm)	(in)
IM060	60	2.36	5.5	0.217	70	2.76	50	1.97	2.5	0.098	12	0.480	1	0.039	80	3.15
IM090	90	3.54	6.5	0.256	100	3.94	80	3.15	3	0.118	15	0.59	1	0.039	120.5	4.74
IM115	115	4.53	8.5	0.335	130	5.12	110	4.33	3.5	0.138	25.4	1.00	1	0.039	152	5.98
IM142	142	5.59	11	0.433	165	6.50	130	5.12	3.5	0.138	25.4	1.00	1	0.039	194	7.64

Frame Size	J Shaft Diameter		K Shaft Length		M Keyway Length		N Keyway Height		P Keyway Width		Q Flange Thickness		S DIN Connector Height		S MIL Connector Height		T Connector Location	
	(mm)	(in)	(mm)	(in)	(mm)	(in)	(mm)	(in)	(mm)	(in)	(mm)	(in)	(mm)	(in)	(mm)	(in)	(mm)	(in)
IM060	11	0.433	25	0.984	15	0.591	13.0	0.511	4	0.157	11	0.437	117	4.61	88	3.45	37	1.46
IM090	14	0.551	30	1.18	20	0.787	16.5	0.650	5	0.197	14	0.590	147	5.79	122	4.82	47	1.85
IM115	19	0.748	50	1.97	35	1.38	22.0	0.866	6	0.236	15	0.591	175	6.89	151	5.94	57	2.24
IM142	24	0.945	50	1.97	35	1.38	24.7	0.972	8	0.315	18	0.709	181.3	7.14	182	7.16	57	2.24



NEMA SIZES

Frame Size	B Bolt Hole		C Bolt Circle		D Pilot Diameter		J Output Shaft		K Output Shaft		M Keyway Length		N Keyway Height		P Keyway Width	
	(in)	(mm)	(in)	(mm)	(in)	(mm)	(in)	(mm)	(in)	(mm)	(in)	(mm)	(in)	(mm)	(in)	(mm)
IM023	0.195	5.0	2.625	66.7	1.500	38.1	0.375	9.5	1.000	25.4	0.750 flat	19.1 flat	0.015 flat	0.4 flat	—	—
IM034	0.218	5.5	3.875	98.4	2.875	73.0	0.500	12.7	1.250	31.8	1.063	27.0	0.072	1.8	0.125	3.2
IM042	0.281	7.1	4.950	125.7	2.187	55.5	0.625	15.9	1.500	38.1	1.130	28.7	0.108	2.7	0.188	4.8

Options	U Length		W Flange Offset		R Recess Length	
	(mm)	(in)	(mm)	(in)	(mm)	(in)
	IM060 Single Stack – Encoder or Resolver	158	6.22	99	3.89	45
IM060 Single Stack – Encoder or Resolver and Brake	188	7.41	129	5.07	45	1.77
IM060 Double Stack – Encoder or Resolver	195	7.20	137	5.40	45	1.77
IM060 Double Stack – Encoder or Resolver and Brake	226	8.90	167	6.60	45	1.77
IM090 Single Stack – Encoder or Resolver	187	7.36	118	4.63	45	1.77
IM090 Single Stack – Encoder or Resolver and Brake	219	8.62	149	5.88	45	1.77
IM090 Double Stack – Encoder or Resolver	225	8.86	156	6.13	45	1.77
IM090 Double Stack – Encoder or Resolver and Brake	257	10.11	187	7.38	45	1.77
IM115 Single Stack – Encoder or Resolver	191	7.52	119	4.69	49	1.93
IM115 Single Stack – Encoder or Resolver and Brake	230	9.05	145	5.70	49	1.93
IM115 Double Stack – Encoder or Resolver	230	9.05	158	6.22	49	1.93
IM115 Double Stack – Encoder or Resolver and Brake	269	10.59	185	7.28	49	1.93
IM142 Single Stack – Encoder or Resolver	261	10.27	178	7.00	75	2.95
IM142 Single Stack – Encoder or Resolver and Brake	302	11.88	180	7.08	75	2.95
IM142 Double Stack – Encoder or Resolver	329	12.95	224	8.82	75	2.95
IM142 Double Stack – Encoder or Resolver and Brake	371	14.60	251	9.88	75	2.95



IM Series: Bearing Life

IM60 Axial Load = 44.5 N/10lb
Radial Load @ 19mm/0.75in from mounting surface

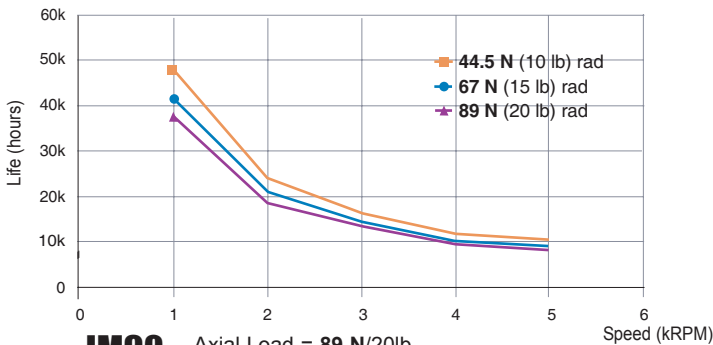

IM90 Axial Load = 89 N/20lb
Radial Load @ 28.6mm/1.125in from mounting surface

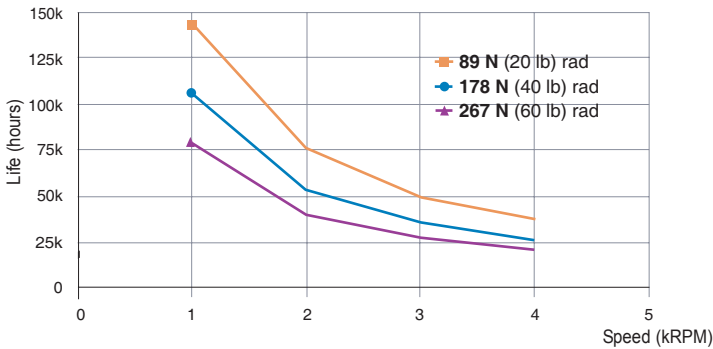

IM115 Axial Load = 89 N/20lb
Radial Load @ 38mm/1.5in from mounting surface

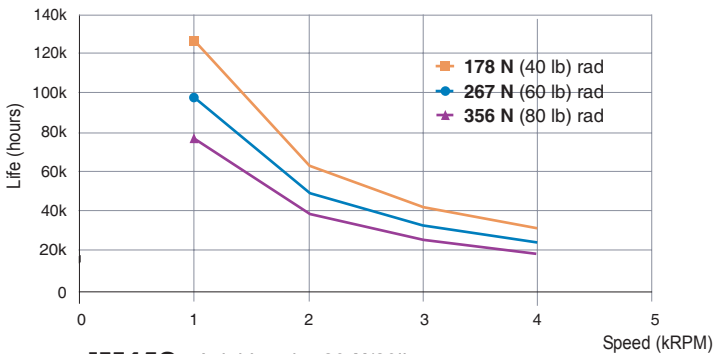

IM142 Axial Load = 89 N/20lb
Radial Load @ 38mm/1.5in from mounting surface

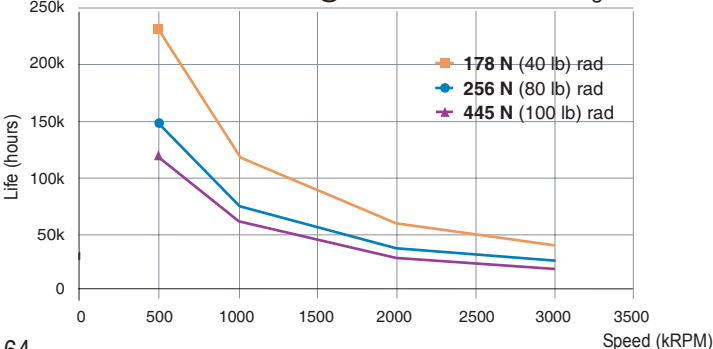

Formulas to calculate Life (L_x) at any distance "X" from the motor mounting surface.

L = Life value from graph

$$L_x = [147\text{mm}/(X + 128\text{mm})]^3 * L$$

$$L_x = [5.77\text{in}/(X + 5.02\text{in})]^3 * L$$

$$L_x = [167\text{mm}/(X + 139\text{mm})]^3 * L$$

$$L_x = [6.59\text{in}/(X + 5.46\text{in})]^3 * L$$

$$L_x = [180\text{mm}/(X + 142\text{mm})]^3 * L$$

$$L_x = [7.1\text{in}/(X + 5.6\text{in})]^3 * L$$

$$L_x = [234\text{mm}/(X + 196\text{mm})]^3 * L$$

$$L_x = [9.2\text{in}/(X + 7.7\text{in})]^3 * L$$

IM Series: Motor Connections & Cables



DIN Motor Power Connection

Pin Number	Function
3	U
1	V
4	W
2	Chassis Gnd.
A	Thermistor +
B	Thermistor -
C	Brake +
D	Brake -
-	Shield

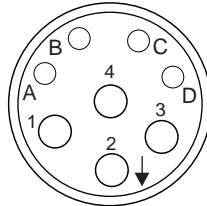

Power



Motor Power Mating Connector

Manufacturer	Part Number	Description
Hypertac	LPNA08BFRKB170	Body
	020.232.2000	4 Pins Female 18-26 AWG
	020.090.1020	4 Pins Female 16-20 AWG

Motor Power Cable

Part Number	Length	Used With
10963093	3 meter	Flying Leads
10963117	8 meter	Flying Leads

DIN Sensor Connector Details

Pin Number	Function		Mating Cable i-Drive Conn. Pin Number
	Encoder	Resolver	
1	A +	S1 (SIN+)	1
2	B +	S4 (COS+)	2
7	+5V	R2 (Ref+)	7
8	Shield	Shield	8
9	A -	S3 (SIN-)	9
10	B -	S2 (COS-)	10
15	Gnd	R1 (REF-)	15
12	Spare	Spare	—
5	I +	—	5
13	I -	—	13
3	Hall 1 (S1)	—	—
11	Hall 2 (S2)	—	—
4	Hall 3 (S3)	—	—
16	Thermistor +	Thermistor +	—
17	Thermistor -	Thermistor -	—
6 & 14	No Connection		—

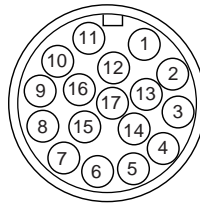

Sensor



Motor Sensor Mating Connector

Manufacturer	Part Number	Description
Hypertac	SPNA17HFRON	Body
	020.256.1020	17 Pins Female

Sensor Mating Cable

Part Number	Length	Used With
10963094	3 meter	Flying Leads
10963096	3 meter	i-Drive
10963123	8 meter	Flying Leads
10963118	8 meter	i-Drive
10963136 ⁽¹⁾	—	i-Drive / Controller

(1) NOTE: When an external controller is used in a closed loop mode an additional sensor cable, part number 10963136, is required.

Flying Leads from out of the Motor (All IM Frame Sizes)

Power

Function	Color Code
U	Red
V	Black
W	White
Ground	Green

Encoder

Function	Color Code
A-	White
A+	Brown
B-	Green
B+	Blue
I-	Yellow
I+	Orange
S2	Violet
S1	White / Brown
S3	White / Orange
+5V	Red
GND	Black
T1	White / Red
T2	White / Black



IM Series: Motor Connections & Cables

MIL Sensor Connector Details (IM 90/115/142)

Pin Number	Function	
	Encoder	Resolver
N	Ground	R1 (REF -)
L	+ 5V	R2 (REF+)
M	T1	
B	S1	
P	T2	
C	S2	
K	I-	
H	I+	
J	B-	S2 (COS-)
F	B+	S4 (COS+)
S	Spare	
D	S3	
A	A-	S1 (SIN+)
E	A	S2 (SIN-)
CASE	Shield	Shield

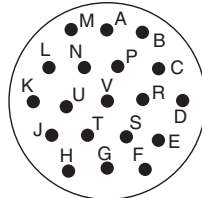

Sensor

Motor Sensor Mating Connector

Manufacturer	Part Number	Description
Canon	KPT06J14-19S	Kit

Sensor Mating Cable

Part Number	Length	Used With
10963011	3 meter	Flying Leads
10963119	3 meter	i-Drive
10963058	8 meter	Flying Leads
10963120	8 meter	i-Drive

MIL Sensor/Power Connector Detail (IM60)

Pin Number	Function	
	Encoder	Resolver
L	A+	S1 (SIN+)
K	A-	S3 (SINE-)
J	B+	S4 (COS+)
H	B-	S2 (COS-)
G	Z+	
F	Z-	
M	+5V	R2 (REF+)
Y	GND	R1 (REF-)
W	S1	
V	S2	
U	S3	
E	T1	T1
D	T2	T2
X	BK1	BK1
T	BK2	BK2
P	U Phase	U
A	V Phase	V
B	W Phase	W
R	P E(GND)	PE

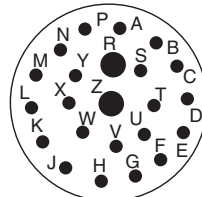

Sensor/Power

Power/Sensor Mating Connector

Manufacturer	Part Number
Canon	KPT01A6-23S

Power/Sensor Mating Cable

Part Number	Length	Used With
10963207	3 meter	Flying Leads
10963208	8 meter	Flying Leads

MIL Power Connector Detail (IM90, IM115, & IM142)

Pin Number	Function	
A	U	
B	V	
C	W	
D	Chassis Gnd	
E	Brake	
F	Brake	

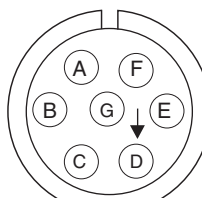

Power

Power Mating Connector

Manufacturer	Part Number
Canon	CA3106E20-15SB

Power Mating Cable

Part Number	Length	Used With
10963021	3 meter	Flying Leads
10963061	8 meter	Flying Leads

IM Series: Timing Diagrams & How to Order



Motor Signal Timing at motor connector

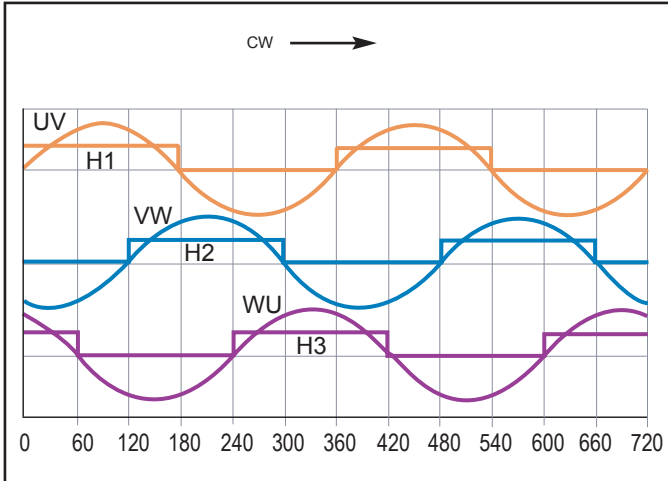

Encoder Timing

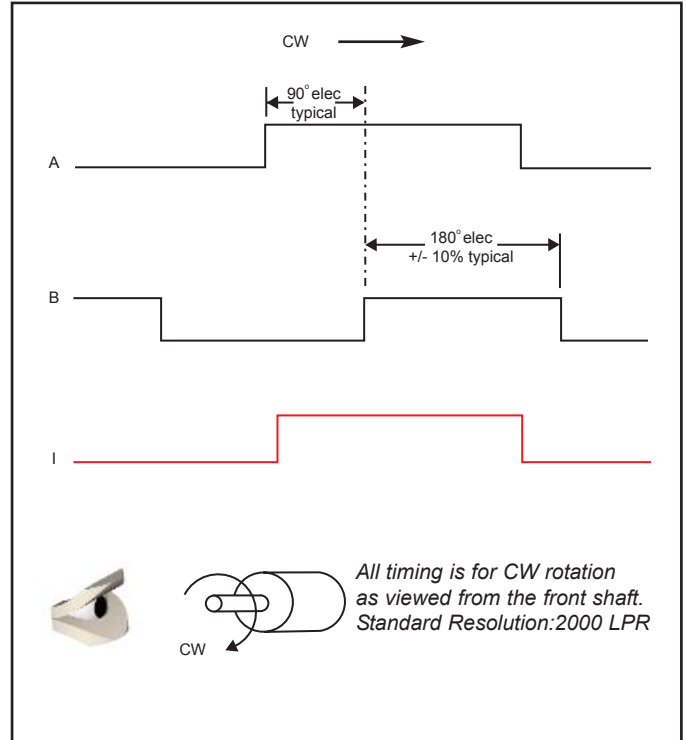

Specifications are subject to change without notice.

How to Order

Order Numbering Example:

I M 1 1 5 - 2 C 2 D 1

Call 1-800-305-4555 for application engineering assistance or for the name of your local distributor.

FRAME SIZE
060
090
115
142
NEMA
023
034
042

STACK LENGTH
1 > 60, 90, 115, 23, 34 & 42
3 > 142
4 > 142

WINDING
C = 160Vdc
D = 300Vdc
E = 660Vdc(1)

OPTIONS
1 = 2000 Line Encoder (2)
2 = 2000 Line Encoder, Brake (2)
3 = Resolver
4 = Resolver, Brake

MOTOR CONNECTOR
A = MIL Connector
D = DIN Connectors Swivel
F = Flying Leads (450mm/18in)

SEAL
1 = Seal
2 = No Seal

(1) E winding not available on IM60 size motors

(2) Includes commutation signals



► **Two-Wire Brushless Motor Series: Reduces Wiring Connection**

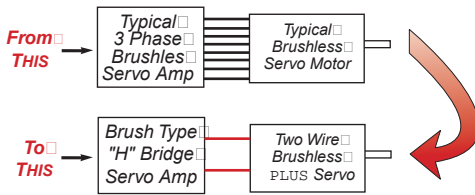

PATENTED TECHNOLOGY

The Two Wire brushless motor combines the improved performance of a brushless motor over a brush motor with a unique electronic module, allowing the motor to be controlled directly from a PWM “H” bridge amplifier or from a DC power source.

For existing brush motor servo systems using “H” drive amplifiers, this allows changing over to brushless technology without replacing either the existing amplifiers or the system cabling with bulkier brushless cables.

Even in new multi-axis designs, the Two Wire brushless motor approach will minimize the weight, bulk and complexity of the cabling and eliminate any confusion about motor phasing connections. In addition, less expensive “H” drive amplifiers can be used instead of three phase brushless amplifiers.

The Two Wire Brushless Servo Motor Offers:

- Easy Upgrade to Brushless Motor Technology by Replacing only the Motor - NOT the drive electronics and cables.
- Simple, Error-Free, Less Bulky Cabling. an Important Feature in Multi Axis Systems.
- Ability to Utilize Existing “Brush Type” Amplifiers while Upgrading to Brushless Motor Technology

When operating from a PWM amplifier, the Two Wire module provides complete four quadrant operation down to maximum torque at zero speed with no dead band.

When operating directly from DC, the Two Wire module provides for bi-directional velocity control over a 3:1 to 8:1 speed range up to maximum rated current.

The size of a Two wire brushless motor is virtually the same size as a comparable brush motor, since the two wire module takes about as much volume as the commutation assembly (commutator bars and brush assembly) in a brush motor.

The Two Wire brushless motor also includes a standard 2,000 PPR encoder within the module, resulting in a complete servo assembly; a two wire, four quadrant brushless motor with integrated encoder.

Four Modules are Available

Model No.	Input Voltage Range	Max Bus Voltage	Input Current	Current Limit
	(DC)	(PWM)	(MAX)	
24V	8 - 24 V	24 V Max	12A	12A
48V	8 - 48 V	48 V Max	12A	12A
160V	20 - 160 V	160 V Max	6A	6A

Example: Motor IM090-1CXX-X Combined with a 160V Module will provide:

Torque = **1.8 Nm** (260 oz in)
 No Load Speed = 4,600 RPM



Dimensions

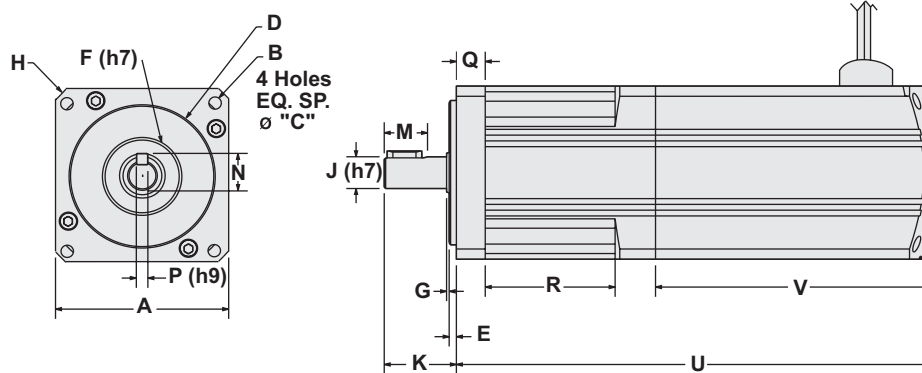

Connectivity:
Available with flying leads
or connectors

Frame Size	A Square Flange		B Bolt Hole		C Bolt Circle		D Pilot Diameter		E Pilot Thickness		F Shoulder Diameter		G Shoulder Height	
	(mm)	(in)	(mm)	(in)	(mm)	(in)	(mm)	(in)	(mm)	(in)	(mm)	(in)	(mm)	(in)
TW090	90	3.54	6.5	0.256	100	3.94	80	3.15	3	0.118	19	0.748	1	0.039

Frame Size	H Housing Diameter		J Shaft Diameter		K Shaft Length		M Keyway Length		N Keyway Height		P Keyway Width		Q Flange Thickness	
	(mm)	(in)	(mm)	(in)	(mm)	(in)	(mm)	(in)	(mm)	(in)	(mm)	(in)	(mm)	(in)
TW090	120.5	4.74	14	0.551	30	1.18	20	0.787	16.5	0.650	5	0.197	13	0.512

Options	U Length		V Rear Cover Length		R Recess Length	
	(mm)	(in)	(mm)	(in)	(mm)	(in)
TW090 Single Stack – Encoder	182	7.17	111	4.37	45	1.77
TW090 Double Stack – Encoder	220	8.66	111	4.37	65	2.56

Specifications are subject to change without notice.

How to Order

Order Numbering Example:

T **W** **0** **9** **0** **2** **C** **1** **F**

FRAME SIZE

090
034

STACK LENGTH

1
2

WINDING

C = 160Vdc
E = 24Vdc
F = 48Vdc

OPTIONS

1 = 2000 Line Encoder

MOTOR CONNECTOR

F = Flying Leads (450mm/14in)

Call 1-800-305-4555 for application engineering assistance or for the name of your local distributor.