



► **NE NEMA Series:**
Lightweight, Compact and Low Friction

Bayside's NEMA gearheads feature a high efficiency spur gear design, in a light, compact package. Designed to mount directly to the face of NEMA face stepper and servo motors, NEMA gearheads are ideal for applications requiring smooth operation and low starting torque. Ratios from 3:1 to 100:1 are available in NEMA 23, 34 and 42 frame sizes.

3 Frame Sizes	
NE23	
NE34	
NE42	

Ratios	
3:1	20:1
5:1	30:1
8:1	50:1
10:1	100:1
15:1	



NE NEMA Series



Performance Specifications

	Units	Ratio	Frame Size		
			NE23	NE34	NE42
Nominal Output Torque, $T_{nom r}$	in-lb	3	16	64	123
	Nm		2	7	14
	in lb	5	27	107	205
	Nm		3	12	23
	in lb	8-10	40	142	250
	Nm		5	16	28
Max. Acceleration Output Torque, $T_{acc r}$	in lb	3	24	95	185
	Nm		3	11	21
	in lb	5	40	160	307
	Nm		5	18	35
	in lb	8-10	60	210	375
	Nm		7	24	42
Nominal Input Speed, $N_{nom r}$	in lb	15	70	255	450
	Nm		8	29	51
	in lb	20-100	75	270	525
	Nm		9	31	59
	RPM	All	4,000	4,000	4,000
	RPM	All	5,500	5,000	4,500
Standard Backlash ⁽¹⁾	arc min	3, 5, 8, 10	30	25	25
	arc min	15-100	20	20	20
Low Backlash ⁽¹⁾	arc min	3, 5, 8, 10	15	15	15
	arc min	15-100	10	10	10
Efficiency at Nominal Torque	%	All	98%	98%	98%
Moment of Inertia	oz in sec ²	All	0.00007	0.0005	0.004
	gm cm sec ²		0.0051	0.0408	0.306
Maximum Weight	lb	All	1.0	3.0	6.0
	kg		0.5	1.4	3.0
Radial Load ⁽²⁾	lb	All	20	80	200
	N		90	350	890
Axial Load	lb	All	10	30	60
	N		45	135	265

(1) Measured at 2% of rated torque

(2) Radial Loads are measured at 12.7mm (0.5in) from the gearhead mounting surface.
These ratings are based on gearhead making more than one revolution on output shaft.

Specification are subject to change without notice



NE NEMA Series

Dimensions

OUTPUT VIEW

SIDE VIEW

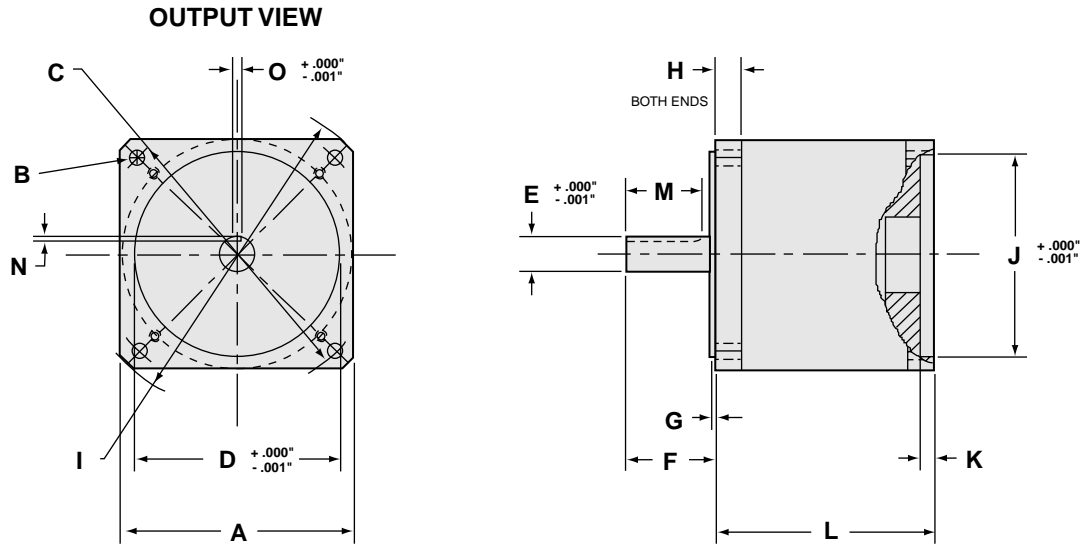

Frame Size	A Square Flange		B Bolt Hole		C Bolt Circle		D Pilot Diameter		E Output Shaft Diameter		F Output Shaft Length		G Pilot Thickness		H Flange Thickness	
	(in)	(mm)	(in)	(mm)	(in)	(mm)	(in)	(mm)	(in)	(mm)	(in)	(mm)	(in)	(mm)	(in)	(mm)
NE 23	2.27	58	0.195	5.0	2.625	66.7	1.500	38.1	0.375	9.5	1.00	25.4	0.062	1.6	0.19	5
NE 34	3.25	83	0.218	5.5	3.875	98.4	2.875	73.0	0.500	12.7	1.25	31.8	0.067	1.7	0.38	10
NE 42	4.20	107	0.281	7.1	4.950	125.7	2.187	55.5	0.625	15.9	1.50	38.1	0.093	2.4	0.50	13

Frame Size	I Housing Diameter		J Input Pilot Diameter		K Input Pilot Depth		L Housing Length		M Keyway Length		N Keyway Depth		O Keyway Width	
	(in)	(mm)	(in)	(mm)	(in)	(mm)	(in)	(mm)	(in)	(mm)	(in)	(mm)	(in)	(mm)
NE 23	3.00	76	1.501	38.13	0.125	3.2	2.30	58	0.75 flat	19 flat	0.015 flat	0.4 flat	—	—
NE 34	4.38	111	2.876	73.05	0.200	5.1	3.00	76	1.06	27	0.072	1.8	0.124	3.15
NE 42	5.63	143	2.188	55.58	0.187	4.7	3.75	95	1.13	29	0.108	2.7	0.187	4.75

NE NEMA Series: How to Order



MOUNTING TO NEMA FRAMED MOTORS: DIRECT MOUNT

Gearheads attach directly to motors with NEMA mounting dimensions (see table). Bayside's Clamp-on-Pinion and mounting hardware is included with gearheads, so your motor can be up and running in a matter of minutes.

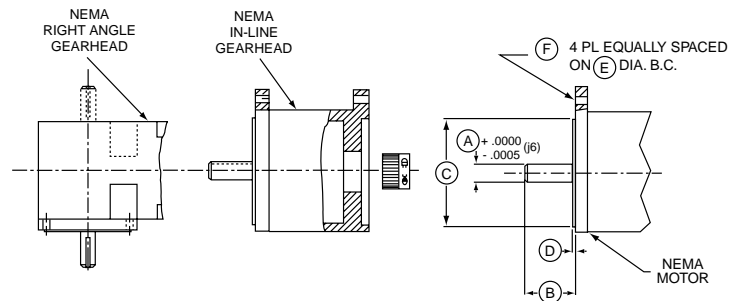

NEMA DIMENSIONS

Motor Mounting Dimensions

Dimension	NE23		NE34		NE42	
	in	(mm)	in	(mm)	in	(mm)
A Motor Shaft Diameter	0.250	(6.4)	.375/.500	(9.5/12.7)	0.625	(15.9)
B Motor Shaft Length	0.810	(20.6)	1.250	(31.8)	1.380	(35.1)
C Pilot Diameter	1.500	(38.1)	2.875	(73.0)	2.186	(55.5)
D Pilot Length	0.063	(1.6)	0.063	(1.6)	0.093	(2.4)
E Mounting Bolt Circle	2.625	(66.7)	3.875	(98.4)	4.950	(125.7)
F Bolt Hole Size	0.195	(5.0)	0.218	(5.5)	0.281	(7.1)

All dimensions are in inches (millimeters).

MOUNTING TO NON-NEMA FRAMED MOTORS: ADAPTER MOUNT

For motors with non-NEMA dimensions, Bayside supplies a mounting kit including a Clamp-On-Pinion, adapter plate and all necessary hardware. When ordering, simply provide the part number or outline drawing of your motor, and the gearhead will be shipped ready-to-mount.

How to Order

Order Numbering Example: **N E 3 4 - 0 1 0 - X X X L B**

FRAME SIZE

23
34
42

RATIO

003 020
005 030
008 050
010 100
015
(all ratios are exact)

SPECIAL

(Factory Issued)

OPTIONAL

LOW BACKLASH

1. Pick frame size and ratio.
2. Pick options.
3. Specify motor make and model for mounting kit.

NEMA Gearheads are supported by a worldwide network of offices and local distributors. Call **1-800-305-4555** for application engineering assistance or for the name of your local distributor. Information can also be obtained at www.baysidemotion.com.



► **NR NEMA Series** **Lightweight, Compact Right Angle**

The Right Angle version of Bayside's NEMA gearheads provides smooth operation, low starting torque and high efficiency in a lightweight, compact package. And with a dual output shaft option, they're flexible enough to work well in a variety of stepper or servo motor applications. Ratios from 1:1 to 100:1 are available in NEMA 23, 34 and 42 frame sizes.



3 Frame Sizes	
NR23	
NR34	
NR42	

Ratios	
1:1	15:1
3:1	20:1
5:1	30:1
8:1	50:1
10:1	100:1

NR NEMA Series



Performance Specifications

	Units	Ratio	Frame Size		
			NR23	NR34	NR42
Nominal Output Torque, T_{nom}	in lb	1-3	16	64	123
	Nm		2	7	14
	in lb	5	27	107	205
	Nm		3	12	23
	in lb	8-10	40	142	250
	Nm		5	16	28
in lb	15	46	170	300	
	Nm		5	19	34
in lb	20-100	50	180	350	
	Nm		6	20	40
Max. Acceleration Output Torque, T_{acc}	in lb	1-3	24	95	185
	Nm		3	11	21
	in lb	5	40	160	307
	Nm		5	18	35
	in lb	8-10	60	210	375
	Nm		7	24	42
in lb	15	70	255	450	
	Nm		8	29	51
in lb	20-100	75	270	525	
	Nm		9	31	59
Nominal Input Speed, N_{nom}	RPM	All	4,000	4,000	4,000
Max. Input Speed, N_{max}	RPM	All	5,500	5,000	4,500
Standard Backlash ⁽¹⁾	arc min	1, 3, 5, 8, 10	30	25	25
	arc min	15-100	20	20	20
Low Backlash ⁽¹⁾	arc min	1, 3, 5, 8, 10	15	15	15
	arc min	15-100	10	10	10
Efficiency at Nominal Torque	%	All	95%	95%	95%
Moment of Inertia	oz in sec ²	All	0.0001	0.0009	0.007
	gm cm sec ²		0.0072	0.065	0.503
Maximum Weight	lb	All	1.0	3.0	6.0
	kg		0.5	1.4	3.0
Radial Load ⁽²⁾	lb	All	150	250	500
	N		670	1,100	2,200
Axial Load	lb	All	75	125	250
	N		335	550	1,100

(1) Measured at 2% of rated torque

(2) Radial Loads are measured at 12.7mm (0.5in) from the gearhead mounting surface.
These ratings are based on gearhead making more than one revolution on output shaft.

Note: Ratio 1:1 is available with coupling drive only.

Specification are subject to change without notice



NR NEMA Series

Dimensions

OUTPUT VIEW

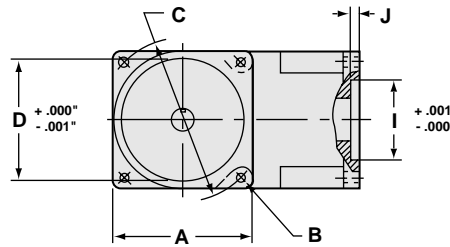

SIDE VIEW

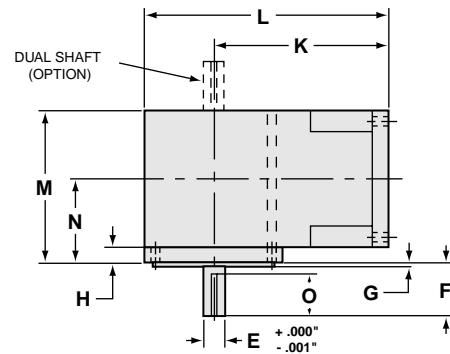

DUAL OUTPUT SHAFT (OPTIONS)

1) DRIVE OPTION "D"	2) ENCODER OPTION "E" ENCODER MOUNTING DIMENSIONS			
	NR23		NR34, NR42	
	in	(mm)	in	(mm)
SHAFT DIAMETER	.375	(9.5)	.375	(9.5)
SHAFT LENGTH	.750	(19.1)	.750	(19.1)
BOLT CIRCLE	1.812	(46.0)	2.952	(75.0)
TAPPED HOLES	4.40 x .25 Min Depth (2PI)		8.32 x .33 Min. Depth (4PI)	
ENCODER	DRC HS, RENCO M1		DRC C25, BEI E25, RENCO C2520	

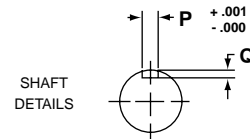
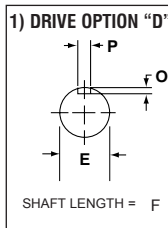

Frame Size	A Square Flange		B Bolt Hole		C Bolt Circle		D Output Pilot Diameter		E Output Shaft Diameter		F Output Shaft Length		G Output Pilot Thickness		H Flange Thickness		I Input Pilot Diameter	
	(in)	(mm)	(in)	(mm)	(in)	(mm)	(in)	(mm)	(in)	(mm)	(in)	(mm)	(in)	(mm)	(in)	(mm)	(in)	(mm)
NR 23	2.27	58	0.195	5.0	2.625	66.7	1.500	38.1	0.375	9.5	1.00	25.4	0.062	1.6	0.22	6	1.501	38.13
NR 34	3.25	83	0.218	5.5	3.875	98.4	2.875	73.0	0.500	12.7	1.25	31.8	0.065	1.7	0.38	10	2.876	73.05
NR 42	4.25	108	0.281	7.1	4.950	125.7	2.187	55.5	0.625	15.9	1.50	38.1	0.093	2.4	0.50	13	2.188	55.58

Frame Size	J Input Pilot Depth		K Dist. to Output Centerline		L Housing Length		M Housing Width		N Dist. to Input Centerline		O Keyway Length		P Keyway Width		Q Keyway Depth	
	(in)	(mm)	(in)	(mm)	(in)	(mm)	(in)	(mm)	(in)	(mm)	(in)	(mm)	(in)	(mm)	(in)	(mm)
NR 23	0.080	2.0	3.09	78	4.22	107	2.49	63	1.36	35	0.75 flat	19 flat	—	—	0.015 flat	0.4 flat
NR 34	0.200	5.1	4.33	110	5.96	151	3.63	92	2.00	51	1.13	29	0.124	3.15	0.072	1.8
NR 42	0.187	4.7	5.38	137	7.50	191	4.75	121	2.63	67	1.13	29	0.187	4.75	0.108	2.7

Specifications are subject to change without notice.

NR NEMA Series: How to Order



MOUNTING TO NEMA FRAMED MOTORS: DIRECT MOUNT

Gearheads attach directly to motors with NEMA mounting dimensions (see table). Bayside's Clamp-on-Pinion and mounting hardware is included with gearheads, so your motor can be up and running in a matter of minutes.

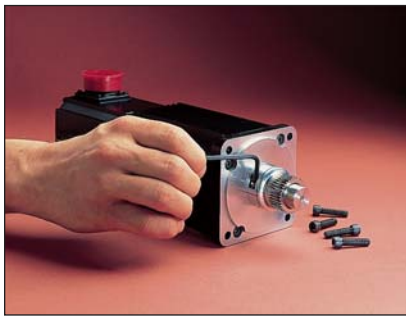
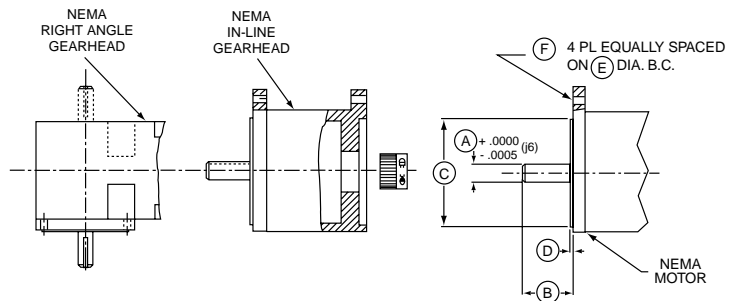

NEMA DIMENSIONS

Dimension	Motor Mounting Dimensions		
	NR23	NR34	NR42
	in (mm)	in (mm)	in (mm)
A Motor Shaft Diameter	0.250 (6.4)	.375/.500 (9.5/12.7)	0.625 (15.9)
B Motor Shaft Length	0.810 (20.6)	1.250 (31.8)	1.380 (35.1)
C Pilot Diameter	1.500 (38.1)	2.875 (73.0)	2.186 (55.5)
D Pilot Length	0.063 (1.6)	0.063 (1.6)	0.093 (2.4)
E Mounting Bolt Circle	2.625 (66.7)	3.875 (98.4)	4.950 (125.7)
F Bolt Hole Size	0.195 (5.0)	0.218 (5.5)	0.281 (7.1)

All dimensions are in inches (millimeters).

MOUNTING TO NON-NEMA FRAMED MOTORS: ADAPTER MOUNT

For motors with non-NEMA dimensions, Bayside supplies a mounting kit including a Clamp-On-Pinion, adapter plate and all necessary hardware. When ordering, simply provide the part number or outline drawing of your motor, and the gearhead will be shipped ready-to-mount.

How to Order

Order Numbering Example:

N R 3 4 - S 0 1 0 - X X X L B

FRAME SIZE

23
34
42

SHAFT

S = Single shaft
D = Double shaft
E = Double shaft
with encoder
mounting

RATIO

001 015
003 020
005 030
008 050
010 100

(all ratios are exact)

SPECIAL

(Factory
Issued)

OPTIONAL

LOW BACKLASH

1. Pick frame size and ratio.
2. Pick options.
3. Specify motor make and model for mounting kit.

NEMA Gearheads are supported by a worldwide network of offices and local distributors. Call **1-800-305-4555** for application engineering assistance or for the name of your local distributor. Information can also be obtained at www.baysidemotion.com.

Specifications are subject to change without notice.

► Specials are Standard at Bayside

Bayside has geared our design and manufacturing capabilities to make custom or modified gearheads quickly and inexpensively.

'Standard' specials include many of the products shown on this page. In addition, we have designed hundreds of gearheads for a wide variety of applications including military, aerospace, food processing, paper mills and other specialized applications. Or, if you simply need a smaller shaft or a different gear ratio, we can accommodate modifications quickly and easily.

Linear Slide

Gearheads ready-to-mount to linear slides.

Most belt driven linear slides need a gearhead to reduce inertia. Bayside has pre-engineered in-line and right angle gearheads to mount directly to most popular linear slides, eliminating the need for couplings or adapters. Standard gearheads are available for the following linear slides: (partial list)

- Bishop Wiscarver
- Daedal
- Hauser
- IKO
- Item Products
- INA
- NSK
- Star Linear
- THK
- Tol-o-Matic
- Warner Rapidtrak
- Warner Tollo

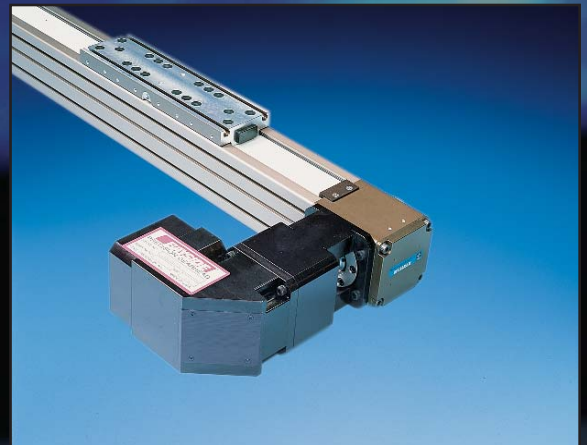

Input Shaft / Speed Reducer

Increased design flexibility.

Stealth gearheads are available with an input shaft option. The input shaft option allows more design flexibility, as options like brakes, encoders, or safety couplings can be used between the motor and the gearhead. Also, non-standard or oversized motors can be easily attached to a Stealth gearhead via an input shaft. Standard input shaft options are available for each model and frame size.



Bayside Gearheads mount to motors from the following companies: (partial list)

AEG
AEROTECH
ALLEN BRADLEY
AMERICAN PRECISION
AMK
ANAHEIM AUTOMATION
APPLIED MOTION PRODUCTS
BALDOR
BAUTZ
BAYSIDE
BODINE
BOSCH
CMC TORQUE SYSTEMS
CONTROL TECHNIQUES
COMPUMOTOR
CUSTOM SERVO MOTORS

DIGIPLAN
EASTERN AIR DEVICES
ELAU
EMERSON
FANUC
GETTYS
GIDDINGS & LEWIS
HITACHI
INDRAMAT
INDUSTRIAL DEVICES
INDUSTRIAL DRIVES
INDUSTRIAL INDEXING
INFRANOR
INLAND MOTOR
INTELLICO
KEB

KOLLMORGEN
MAGNETEK
MAVILOR
MITSUBISHI
MOOG
NIKKI DENSO
NUM
NYDEN
OMRON
ORIENTAL MOTOR
ORMEC
PACIFIC SCIENTIFIC
PANASONIC
PARVEX
PITTMAN
PMI

RELIANCE
ROCKWELL AUTOMATION
SANYO DENKI
SEIDEL
SEM
SHINKO
SIEMENS
SINANO
SONY
SUPERIOR ELECTRIC
TAMAGAWA
TOEI
VICKERS
WARNER
YOKOGAWA
YASKAWA



Patented ServoMount® system for easy mounting to ANY servo motor.

Military Spec Gearheads

Mil-spec quality at commercial prices.

Bayside has extensive experience in military and aerospace applications. The Stealth Bomber, M1 Tank and the Space Shuttle all used Bayside gearheads. Bayside's quality system has been approved by NASA and the US Government to MIL-I-45208A. In today's world of tight military budgets, Bayside can give you a mil-spec gearhead at commercial pricing.



Special Environment

Put A Bayside Anywhere!

Bayside can supply gearheads to operate in the harshest environments:

Vacuum - Available as a standard option to 10⁻⁷ Torr vacuum ratings.

Clean Room - Special gearheads for Class 100 clean room applications.

High Temperature - Special lubricants and seals for temperatures up to 250° Celsius.

Radiation - Gearheads customized to operate within radioactive environments.

Food Grade - Gearheads customized to operate within food handling environments



Bayside Gearhead Selection

Selecting a gearhead for a particular application involves the consideration of a number of interrelated parameters. These are:

- ▶ Speed
- ▶ Continuous torque
- ▶ Repetitive peak torque or acceleration torque
- ▶ Emergency stop torque
- ▶ Duty cycle
- ▶ Ambient temperature
- ▶ Radial and axial shaft load

Bayside has prepared the following procedure that will provide a straight forward method for selecting a gearhead that will provide an L-10 life of 10,000 hours.

In this procedure, two rating factors must be used, which derate the gearhead to compensate for thermal and application related torque effects.

▶ **K_T** - The Torque Thermal Factor

This factor derates the transmitted torque to prevent case temperature from exceeding 100 degree C. The Thermal Factors given in the table are for ambient temperature 25 degree C, medium size indoor space, with the gearheads mounted to a metal base with a surface area more than 3 times larger than the gearhead surface area.

TORQUE THERMAL FACTOR, K_T

Frame Size	Ratio	Output Speed, (RPM)									
		100	200	400	600	800	1,000	1,500	2,000	2,500	3,000
PS40		1	1	1	1	1	1	—	—	—	—
PS, PX, RS60		1	1	1	1	1	1	—	—	—	—
PS, PX, RS90		1	1	1	1	1	1.2	—	—	—	—
PS, PX, RS115		1	1	1	1	1.2	1.5	—	—	—	—
PS, RS142		1	1	1	1.3	1.7	—	—	—	—	—
PS, RS180	1 stage ⁽¹⁾	1	1	1.5	2.3	—	—	—	—	—	—
	2 stage ⁽²⁾	1.1	1.5	—	—	—	—	—	—	—	—
PS, RS220	1 stage ⁽¹⁾	1	1.2	2.1	3.2	—	—	—	—	—	—
	2 stage ⁽²⁾	1.3	2.5	—	—	—	—	—	—	—	—
PS, RS300	1 stage ⁽¹⁾	1	1.5	3.1	—	—	—	—	—	—	—
	2 stage ⁽²⁾	1.9	—	—	—	—	—	—	—	—	—
R_90	1	1	1	1	1	1	1	1	1	1.25	1.5
	2-30	1	1	1	1	1	1	1.1	—	—	—
R_115	1	1	1	1	1	1	1	1	1.3	1.7	—
	2-30	1	1	1	1	1	1.3	2	—	—	—
R_142	1	1	1	1	1	1	1.3	2	2.7	3.4	—
	2-30	1	1	1	1	1.3	1.6	—	—	—	—
R_180	1	1	1	1	1	1.3	1.7	2.5	3.4	—	—
	2-30	1	1	1	1.4	1.8	2.3	—	—	—	—
R_220	1	1	1	1.2	1.8	2.4	3.0	4.5	—	—	—
	2-30	1	1	1.3	2.0	2.6	—	—	—	—	—

(1) Data given for PS 3:1 to 10:1 and all RS ratios

(2) Data given for PS ratios above 10:1

▶ **K_S** - The Shock Factor

This factor is used to derate the transmitted torque for applications where the application is not well defined, has random duty cycles or experiences varying peak torques subjecting the gear teeth to torques above the estimated torques.

A K_S has been defined for four general application categories, as shown below, and is independent of gearhead size. If your application does not fit into one of these categories, contact Bayside to discuss your requirements.

	Load Type	Application	K _S
Known Load Data		All Industries	1.00
	Light	Textiles, liquid mixers, can filling, food, conveyors, plastics, fans	1.25
Unknown Load Data	Moderate	Paper mills, rubber industry, sugar industry, metal mills, lumber, robotics	1.50
	Heavy	Cranes, punching machines, rolling mills	1.75

9 Step Procedure

1 Load Parameters

Evaluate the following requirements of the load:

- Load inertia
- Acceleration time (t_{acc})
- Continuous run time (t_{cont})
- Deceleration time (t_{dec})
- Dwell time (t_{dwell})
- Maximum continuous speed (N_{cont})

From these, calculate:

- Acceleration torque (T_{acc})
- Continuous run torque (T_{cont})
- Deceleration torque (T_{dec})
- Dwell torque (T_{dwell})*

*Although not used in the following torque calculations, torque requirements during dwell (zero speed) must be considered when selecting gearhead size.

2 Duty Cycle

Determine if the application is to be considered as **intermittent** or **continuous** by calculating the duty cycle as follows:

$$\text{Duty Cycle} = \frac{(t_{acc} + t_{cont} + t_{dec})}{t_{total}} \times 100$$

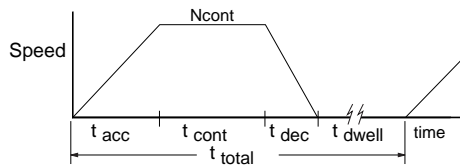

If the duty cycle is $< 60\%$, and ($t_{acc} + t_{cont} + t_{dec}$) is less than 20 minutes, the motion is considered to be **intermittent**.

If the duty cycle is $\geq 60\%$, or ($t_{acc} + t_{cont} + t_{dec}$) is greater than 20 minutes, the motion is considered to be **continuous**.

3 Calculate the Root Mean Cube Output Torque, T_{mean} .

$$T_{mean} = \sqrt[3]{\frac{[(T_{acc}^3)(N_{cont})(t_{acc}) + (T_{cont}^3)(N_{cont})(t_{cont}) + (T_{dec}^3)(t_{dec})]}{2} \div \frac{[(N_{cont})(t_{acc}) + (N_{cont})(t_{cont}) + (N_{cont})(t_{dec})]}{2}}$$

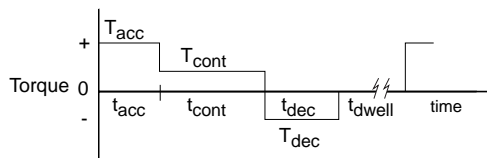

4 Select a gearhead type; PS, PX, RS, Multi-drive, NE or NR (Match gearhead frame size to motor frame size)

5 Review the catalogue listings and determine the gearhead size (40 thru 300) which can meet the following criteria:

$$T_{mean} \leq T_{nomr}$$

$$T_{acc} \text{ and } T_{dec} \leq T_{accr}$$

6 Determine the maximum rated input speed (N_{maxr}) for the selected gearhead.

7 Using N_{cont} and N_{maxr} from step 6, determine the maximum allowable ratio as:

$$\text{Max ratio} = \frac{N_{maxr}}{N_{cont}}$$

8 Select an actual ratio from the catalogue listing and calculate the mean input speed, N_{meani} and the maximum input speed, N_{maxi} , as follows:

$$N_{meani} = \left(\frac{\frac{(N_{cont})(t_{acc}) + (N_{cont})(t_{cont}) + \frac{(N_{cont})(t_{dec})}{2}}{2}}{t_{acc} + t_{cont} + t_{dec}} \right) (\text{RATIO})$$

$$N_{maxi} = (N_{cont})(\text{RATIO})$$

Note: Reflected inertia requirement may determine the actual ratio, as long as it does not exceed the maximum value calculated in STEP 7.

9

	CONTINUOUS MOTION	INTERMITTENT MOTION
Select factor	K_T and K_S	K_S
Calculate	$(T_{mean})(K_T)(K_S)$	$(T_{mean})(K_S)$
Determine that	$T_{nomr} > (T_{mean})(K_T)(K_S)$	$T_{nomr} > (T_{mean})(K_S)$

- ▶ Compare the required accelerate and decelerate torques, T_{acc} / T_{dec} , to the rated accelerate torque, T_{accr} .

T_{accr} must be greater than the larger of T_{acc} or T_{dec} .

- ▶ Check the Emergency Stop Torque rating.
- ▶ Compare N_{meani} with the nominal rated speed, N_{nomr} .

N_{nomr} must be greater than N_{meani}

- ▶ Compare the maximum input speed N_{maxi} with the maximum input speed rating, N_{maxr} .

N_{maxr} must be greater than N_{maxi}

- ▶ Verify radial and axial shaft load.
- ▶ If any of these comparisons are not met, then:

- ▶ Choose a larger gearhead
- ▶ Reevaluate the ratio
- ▶ Reevaluate the torque
- ▶ Reevaluate the speed
- ▶ Reevaluate the duty cycle
- ▶ Reevaluate shaft load

SELECTION PROCESS IS COMPLETE

!