

Gearmotors & Gearheads



► Stealth[®] Planetary Gearmotors



202 GM Servo Gearmotors
Brushless servo motor integrated with a helical planetary gearhead

216 DX Servo Wheel
Brushless servo motor integrated with planetary gearhead and polyurethane wheel



► Stealth[®] Planetary Gearheads

224 PS Advanced In-Line
Helical planetary technology for low backlash and high torque requirements

232 PX In-Line
Helical planetary technology in a lower cost package for less demanding servo applications

236 RS Advanced Right Angle
Delivers "The Helical Advantage" in a compact, right angle package

244 RX Right Angle
Helical planetary technology in a lower cost package for less demanding servo applications

248 MultiDrive Right Angle
MultiDrive models include Low Ratio (RB), Dual Shaft (RD) and Hollow Shaft (RT) options in a compact, right angle package



Table of Contents



► NEMA Spur Gearheads



256 NE In-Line NEMA
High efficiency spur gear design, in a light, compact package



260 NR Right Angle NEMA
High efficiency spur gear design in a lightweight right angle compact package



= Stealth[®] Planetary Gearmotors

202 GM Servo Gearmotors

216 DX Servo Wheel



= Stealth[®] Planetary Gearheads

224 PS Advanced In-Line

232 PX In-Line

236 RS Advanced Right Angle

244 RX Right Angle

248 MultiDrive Right Angle



= NEMA Gearheads

256 NE In-Line NEMA

260 NR Right Angle NEMA

264 Specials

266 Gearhead Selection



= Engineering Reference

316 Gearmotors & Gearheads

► Gearmotors & Gearheads: Application Solutions

Stealth Gearmotors for Office Automation

APPLICATION CHALLENGE

A manufacturer of Pressure Form-Folder/Sealers, Bri-Lin, had a desire to develop a new product to replace their current table top model. The current model is typically used in the production of W2, Wage, and Education Grade report forms. The success of their new model was dependent on a number of design criteria required for an office setting inclusive of size, quiet operation with little to no maintenance. On the mechanical side, the requirements for speed control and constant torque was a must; but the critical objective of the new model would be a major productivity improvement over the 5,000 to 7,000 forms per hour offered by their present model.

Design Change Criteria:

- Existing machine frame width must be maintained as these models are designed for desk top use utilizing 8½ x 11 inch sheets. To maintain registration and speed control a DC servo is required. A brushless motor would be preferred for low maintenance and a "no dust" environment. This frame size does not accommodate an in-line or right angle gearbox even if the cost could allow it.
- A Gearmotors option would meet the speed/torque and size requirements, but the cable cost and connector size would be an issue.
- Cut the one month delivery cycle of complete machine in half by utilizing a JIT component supplier with less than two week lead times.

Stealth Gearheads on High Speed Milling Machines

APPLICATION CHALLENGE

The manufacturer of high speed milling machines used in the Aerospace industry. These milling machines are becoming more commonplace in the aerospace and automotive industry because it allows large structural components to be machined from one piece, where before they were assembled from many smaller subcomponents. In high speed milling, spindle heads are operating at speeds ranging from 18,000 to 40,000 RPM, so that the cutting is above the resonant frequency of the machine. Because of this, many characteristics become more critical than in standard machines. The extremely large size of the spindle head also posed problems for the customer in trying to keep it accurately positioned during the milling stage.

Low Stiffness

The spindle head was moved rotationally by 2 bull gears, driving a large ring gear. Because of the system characteristics, it was difficult to keep the spindle head absolutely stiff during the milling process. The problems associated with low stiffness are:

1. Poor surface finish
2. Accuracy errors
3. Excessive tool chatter
4. Reduced tool life

Stealth Gearheads on a Bottling Application

APPLICATION CHALLENGE

The manufacturer of high performance plastic extrusion equipment. They needed a drop-in replacement gearhead for an existing worm gearbox used with their motor without having to alter the design of their machine. The gearhead/motor combination is being used to drive the machine's rollers. It controls the speed at which the plastic is extruded into high quality plastic sheets. The smoothness of the rollers is critical to the quality of the plastic sheets being produced.

► High Transmission Error and Velocity Ripple.

The customer used worm gearheads to control the rollers. Worm gears exhibit a sliding action, of involute gears instead of a rolling action, contributing to the lack of smoothness of the machine rollers. Due to the high transmission error and velocity ripple from the worm drive, the rollers operated at differing speeds. This produced small lines and imperfections on the plastic sheets, rendering it unusable.

► High Wear and Low Efficiency

The high level of rubbing (sliding action) between the worm and wheel teeth in the worm gearhead caused a high gear tooth wear rate and a lower efficiency (70%) than other major gear types.

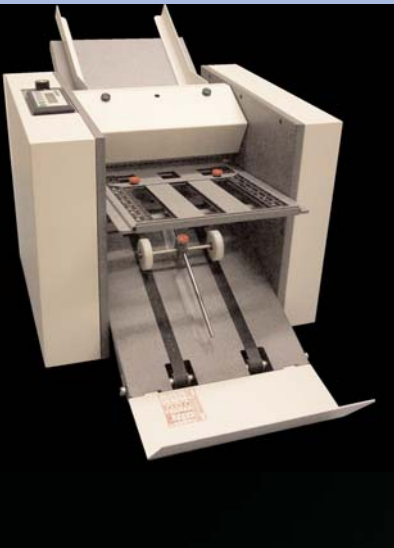

BAYSIDE SOLUTION

GM90-D1A2F Brushless Servo Gearmotors with 10:1 ratio, with flying leads option.

- ▶ The Bayside solution provided a cost effective package of less than 8 inch overall length with a speed/torque capability that offered a 4 X productivity improvement, raising rates of production to 20,000 forms/hour. The incremental cost was nearly zero with reduced noise and need for routine maintenance. The one-piece Gearmotors design with the rotor, sun gear and motor magnets attached, reduces the need for multiple seals and bearings. The resulting package of the helical planetary Brushless DC Gearmotors was a small, quiet, powerful machine that runs clean and cool. The IP65 and stainless steel output shaft also lends itself to wet applications.
- ▶ Plans are now underway for the next generation. A 30,000 form/hour unit on the drawing board utilizing Bayside's next step up in Gearmotors frame size, based on success of the tested 20,000/hour Form Folder/Sealer.
- ▶ This solution can be used in a variety of applications including:
 1. Packaging Industry
 2. Printing/Graphics Industry
 3. Medical/Pharmaceutical
 4. Office Automation



BAYSIDE SOLUTION

(2) Stealth PS142 Helical Planetary Gearheads

- ▶ The above Stealth Gearheads were used in tandem to create a stiff platform for the spindle machine head. One gearhead, acting as the master, and the other as the slave, were attached to the bull gears to simultaneously turn the ring gear which positioned the machine head. While the master gearhead moved the ring, the slave was taking up the backlash. In this way, the precision gears allowed for spindle to be moved accurately, while the two gearhead combination maintained maximum system stiffness.
- ▶ Bayside's Stealth PS gearhead features an all helical planetary gear design. Helical gears have a much higher tooth contact ratio and greater face width than straight spur gears, providing higher loads, smoother tooth engagement and quieter operation. The Stealth's HeliCrown Gear Tooth design provides extremely high gear tooth accuracy, while minimizing tooth wear. Bayside's Plasma Nitriding heat-treating process further heightens the gear tooth's wear resistance.
- ▶ This solution can be used in the aerospace and automotive industries.

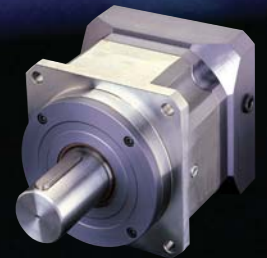

BAYSIDE SOLUTION

(1) Stealth PS Gearhead and (1) Stealth RT MultiDrive (throughbore) Gearhead

- ▶ The above Stealth Gearhead products were used in combination to provide the required 120:1 ratio. The result was high quality plastics sheets that exceeded the customers specifications.
- ▶ The Stealth's all helical planetary design (**HeliCrown Gear Tooth**) features extremely high gear tooth accuracy, minimizing transmission error and velocity ripple. The HeliCrown design features extremely high efficiency (98%) while minimizing tooth wear by providing a pure rolling action. Bayside's Plasma Nitriding heat-treating process further heightens the gear tooth's wear resistance.
- ▶ The Stealth MultiDrive gearhead features a space saving thru-bore (hollow shaft) option, eliminating compliance that occurs when coupling a gearhead shaft to the rollers being driven.
- ▶ This solution can be used for a variety of applications including:
 1. Packaging
 2. Food
 3. Semiconductor
 4. Automotive
 5. Medical

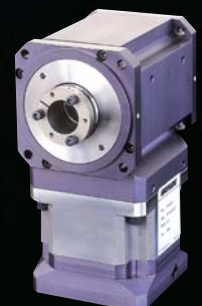



► **Stealth[®] GM Gearmotors Series**

Bayside's Stealth[®] Gearmotors (GM) represents the first time a brushless servo motor and a helical planetary gearhead have been integrated into a single product.

3 Frame Sizes

GM60	GM23
GM90	GM34
GM115	GM40

Ratios

5:1
7:1
10:1

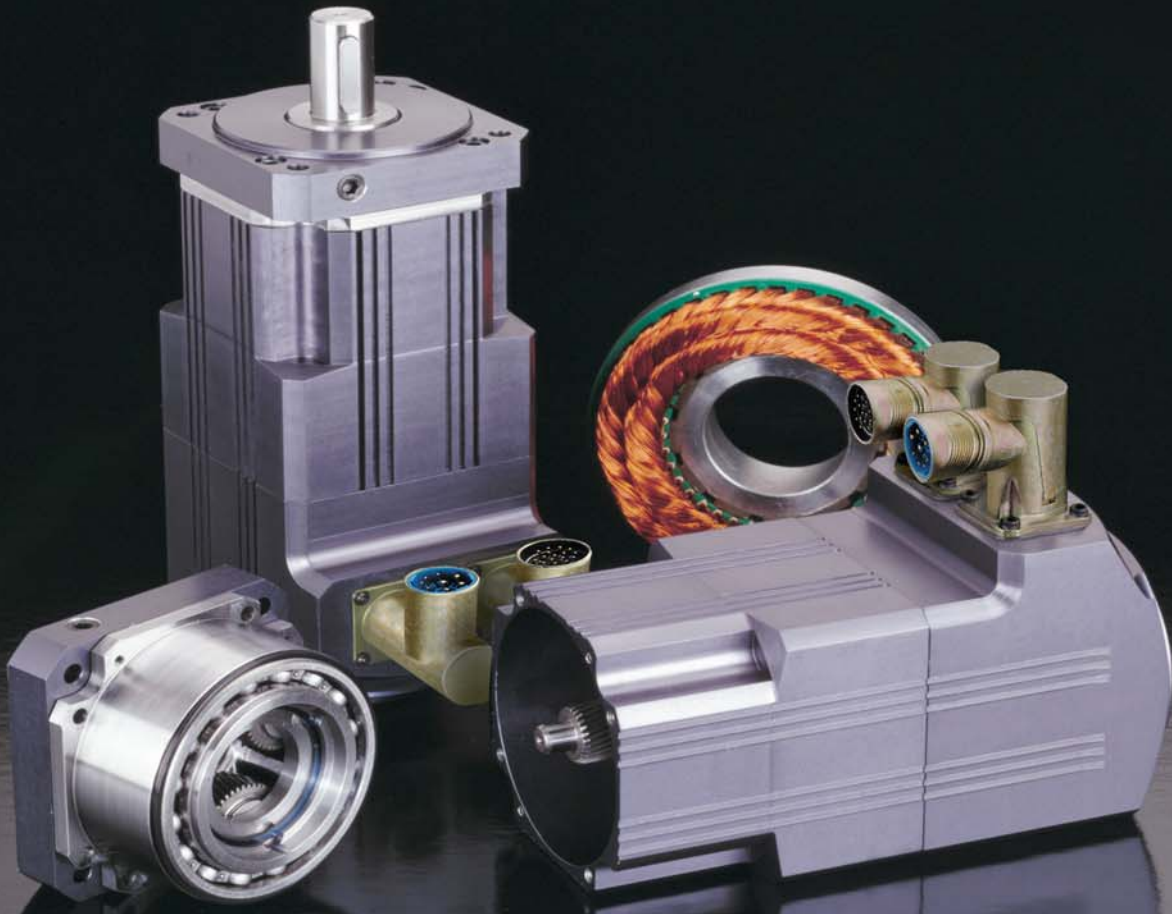

Stealth[®] GM Gearmotors Series: Output Shaft Load Rating



Formulas to calculate Radial Load (P_{rx}) at any distance "X" from the gearhead mounting surface.

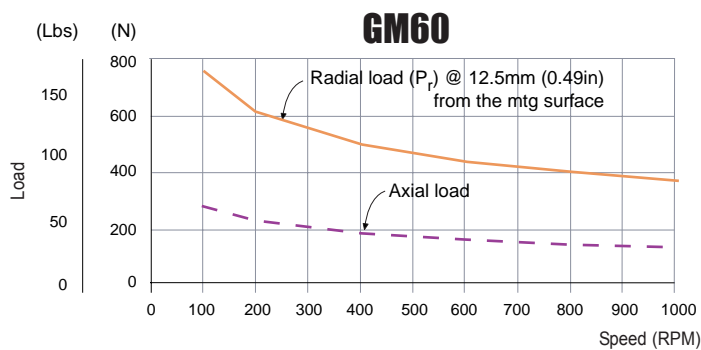

$$P_{rx} = (P_r)(54\text{mm}) / (41\text{mm} + X)$$

$$P_{rx} = (P_r)(2.13\text{in}) / (1.61\text{in} + X)$$

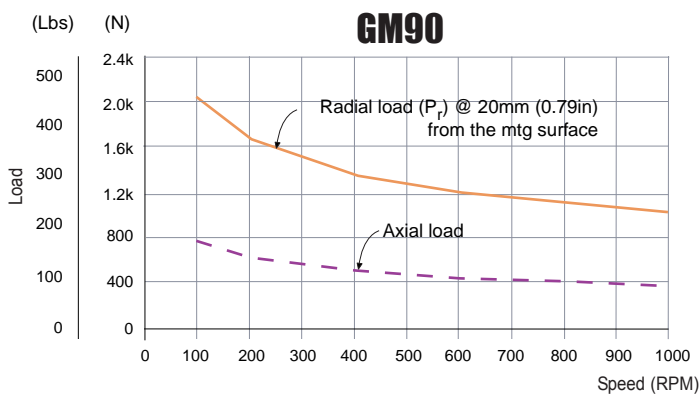

$$P_{rx} = (P_r)(73\text{mm}) / (52\text{mm} + X)$$

$$P_{rx} = (P_r)(2.87\text{in}) / (2.05\text{in} + X)$$

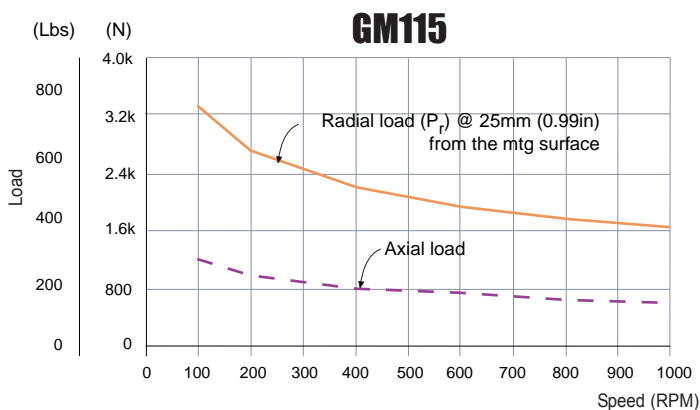

$$P_{rx} = (P_r)(89\text{mm}) / (63\text{mm} + X)$$

$$P_{rx} = (P_r)(3.5\text{in}) / (2.48\text{in} + X)$$



▶ **Stealth[®] GM Gearmotors Series:** **An Integrated Step Forward**

When to Use:

- ▶ High torque in compact package
- ▶ Reduce mechanical complexity
- ▶ Cost reduction

Applications:

- ▶ Automotive
- ▶ Machine Tool
- ▶ Material Handling
- ▶ Medical
- ▶ Packaging
- ▶ Paper Converting
- ▶ Robotics
- ▶ Semiconductor

Bayside's Stealth[®] Gearmotors represents the first time a brushless servo motor and a helical planetary gearhead have been integrated into a single product. Previously, engineers needing a gear drive with servo motor were forced to purchase the gearhead and motor separately. Bayside manufactures precision gearheads and brushless motors under one roof. This provides us with the unique ability to design and supply a precision integrated gearmotors.

Stealth[®] Gearmotors combine both mechanical and electronic parts into a compact, powerful package. The motor magnets are attached directly to the input gearshaft, eliminating the extra couplings, shafts and bearings required when the two components are separate. Eliminating these extra parts means that Stealth Gearmotors are more reliable, have higher performance and cost less than traditional motor/gearhead assemblies.

1 Large Output Bearings
for high radial loads

2 IP65 Protection
with Viton seals, DIN-type connectors, O-rings and an anodized aluminum alloy housing for use in harsh environments

3 High Density Copper Windings and Rare-Earth Magnets
provides maximum torque and efficiency

4 Skewed Laminations with Odd Slot Counts
reduce cogging

5 Duplex Angular Contact Bearing for optimum motor assembly stiffness

6 Modular Encoders, Resolvers and Brakes
offered standard without increasing package size

7 Two Winding Options, Single or Double Stack Motors and Multiple Gear Ratios
for a wide range of torques and speeds

8 Single Piece Construction
of rotor and sun gear guarantees alignment for smooth operation

9 Motor, Gearhead and Encoder
in one compact package eliminates extra parts, improving reliability and performance

10 Stealth[®] Helical Planetary Output
provides high torques, low backlash and quiet, reliable performance

11 Innovative Thermal Design
runs 20% cooler than a separate motor/gearhead assembly

12 Stainless Steel Output Shaft
won't rust in corrosive environments



Motor and Gearhead All-In-One

Stealth® Gearmotors fit in-line for maximum design flexibility.

Using an integrated servo gearmotors rather than a traditional gearhead/motor combination saves valuable space and gives machine designers a wider range of options.

With typical gearhead/motor combinations, space limitations often force designers to use a right angle design. Our integrated gearmotors are smaller, so they fit in-line. In addition to taking up less space, they also provide even better performance.

Industries currently using planetary gearheads attached to servo motors can benefit from using Stealth® Gearmotors.

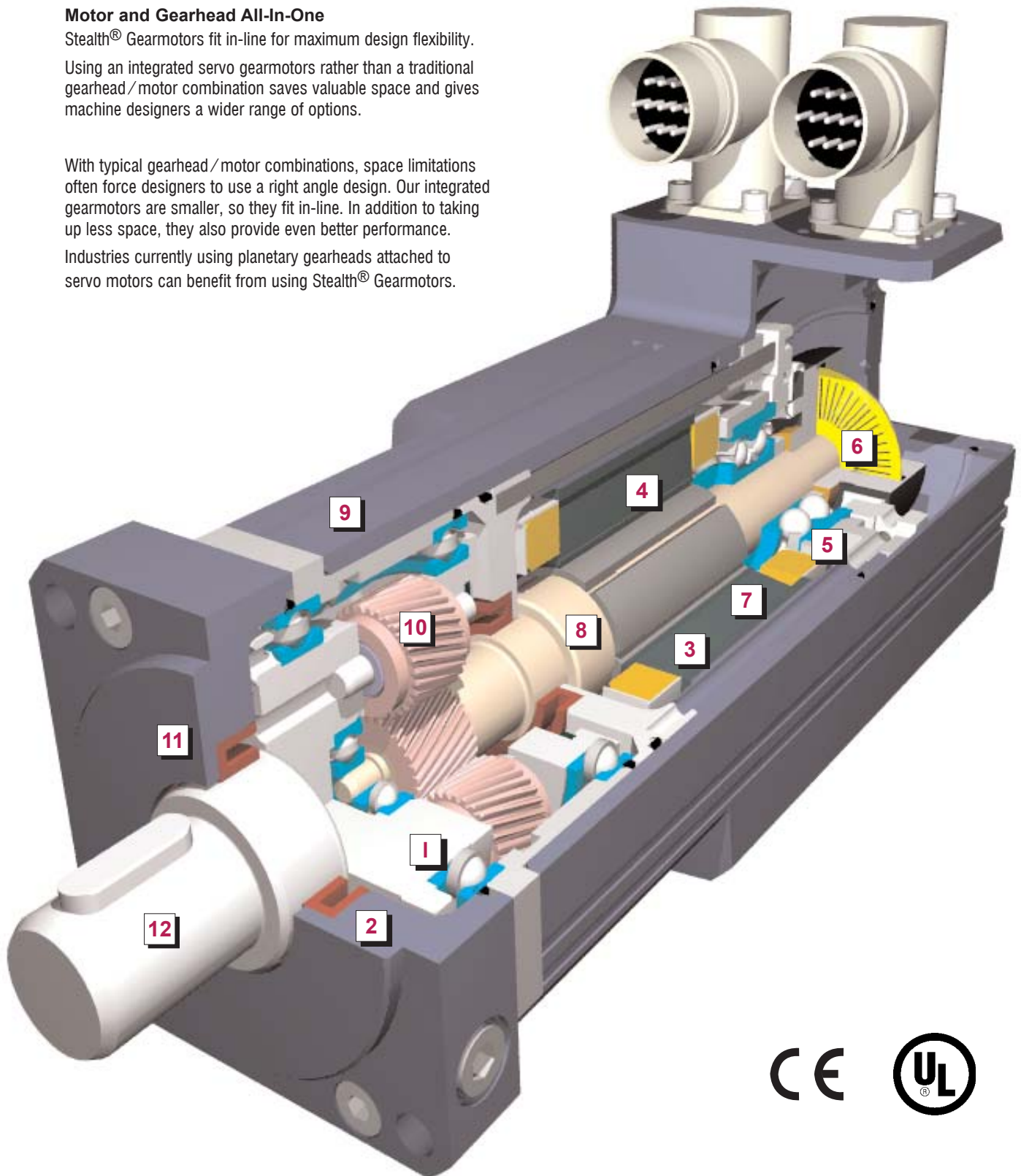



Stealth[®] GM Gearmotors Series: GM60 Speed / Torque Curves

Single Stack - 160 volt

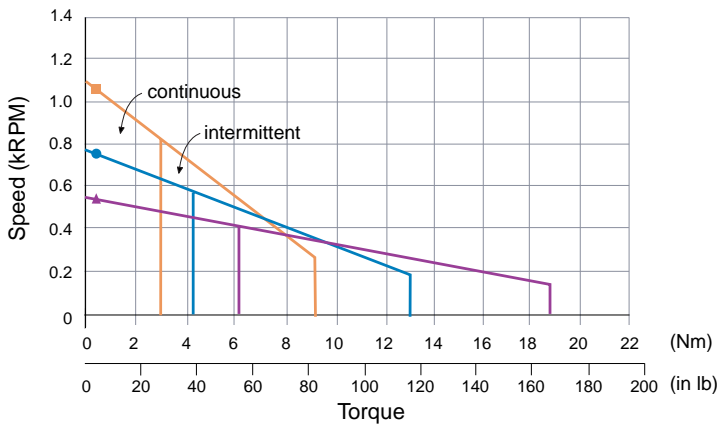

Single Stack - 300 volt

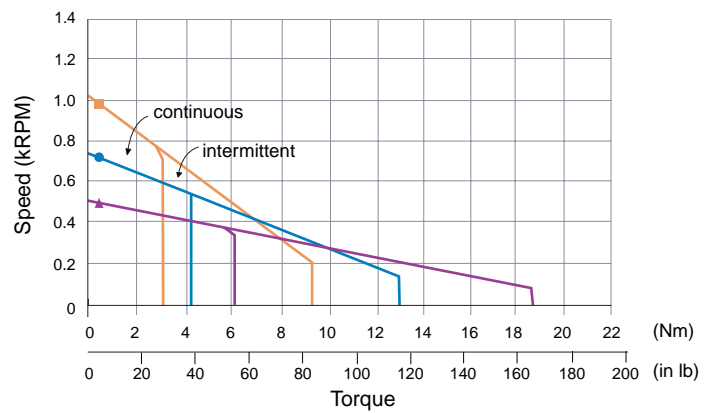

5:1



7:1



10:1



Double Stack - 160 volt

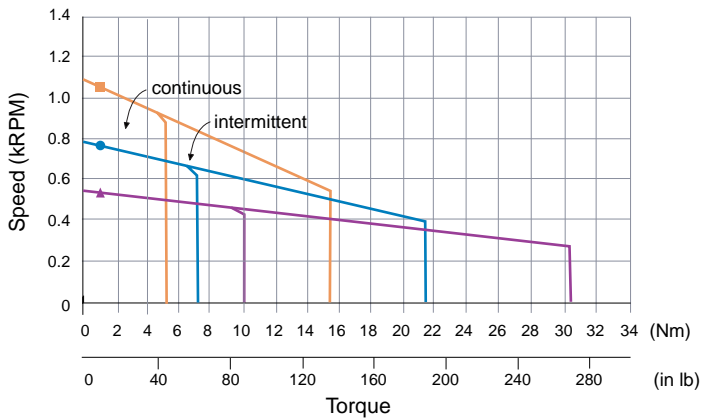

Double Stack - 300 volt

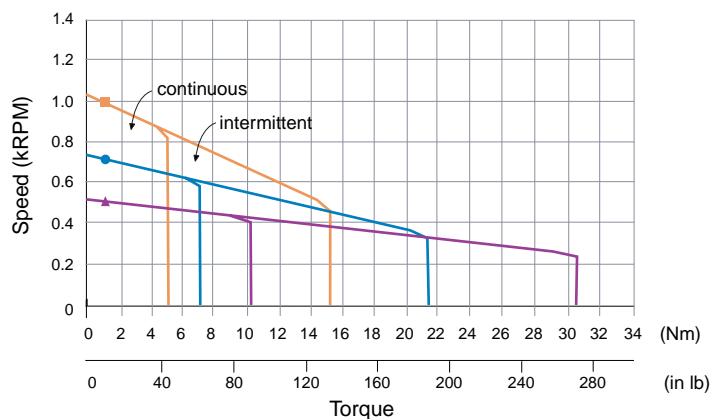

Stealth[®] GM Gearmotors Series: GM60



Performance Specifications (six step/trapezoidal commutation)

Mechanical Specifications

Frame Size	Stack Length	Weight without Brake		Maximum Radial Load		Torsional Stiffness		Standard Backlash *	Low Backlash *
		(kg)	(lb)	(N)	(lb)	(Nm/arc min)	(in lb/arc min)		
GM060	Single	2.1	4.7	1,300	292	6	53	15	10
GM060	Double	2.8	6.2	1,300	292	6	53	15	10

* Measured at 2% of rated torque

Single Stack Specifications

Frame Size	Ratio	Max. Speed ⁽¹⁾ (RPM)	Cont. Stall Torque ⁽¹⁾ T _C		Peak Torque ⁽¹⁾ T _P		Winding C:160 Vdc D:300 Vdc	Voltage Constant ⁽¹⁾⁽³⁾ K _{EL-L} (V/kRPM)	Torque Constant ⁽¹⁾⁽³⁾ K _{TL-L}		Induct L _{L-L} (mH)	Cold Resistance R _{L-L} (ohms)	Cont. Current I _C (amps)	Peak Current I _P (amps)	Inertia ⁽²⁾	
			(Nm)	(in lb)	(Nm)	(in lb)			(Nm/amp)	(in lb/amp)					(gm cm sec ²)	(lb in sec ²)
GM060	5:1	1,100	3.1	27.5	9.3	82.5	C	146.5	1.40	12.5	12.5	11.8	2	7	0.23	0.00019
GM060	5:1	1,000	3.1	27.5	9.3	82.5	D	296.5	2.85	25.0	51.2	48.3	1	3	0.23	0.00019
GM060	7:1	780	4.3	38.5	13.0	115.5	C	205.1	1.96	17.5	12.5	11.8	2	7	0.19	0.00016
GM060	7:1	720	4.3	38.5	13.0	115.5	D	415.1	3.99	35.0	51.2	48.3	1	3	0.19	0.00016
GM060	10:1	540	6.2	55.0	18.6	165.0	C	293.0	2.80	25.0	12.5	11.8	2	7	0.19	0.00016
GM060	10:1	500	6.2	55.0	18.6	165.0	D	593.0	5.70	50.0	51.2	48.3	1	3	0.19	0.00016

Double Stack Specifications

Frame Size	Ratio	Max. Speed ⁽¹⁾ (RPM)	Cont. Stall Torque ⁽¹⁾ T _C		Peak Torque ⁽¹⁾ T _P		Winding C:160 Vdc D:300 Vdc	Voltage Constant ⁽¹⁾⁽³⁾ K _{EL-L} (V/kRPM)	Torque Constant ⁽¹⁾⁽³⁾ K _{TL-L}		Induct L _{L-L} (mH)	Cold Resistance R _{L-L} (ohms)	Cont. Current I _C (amps)	Peak Current I _P (amps)	Inertia ⁽²⁾	
			(Nm)	(in lb)	(Nm)	(in lb)			(Nm/amp)	(in lb/amp)					(gm cm sec ²)	(lb in sec ²)
GM060	5:1	1,100	5.1	45.0	15.2	135.0	C	146.5	1.40	12.5	6.2	4.8	4	11	0.29	0.00025
GM060	5:1	1,000	5.1	45.0	15.2	135.0	D	293.0	2.80	25.0	25	19	2	5	0.29	0.00025
GM060	7:1	780	7.1	63.0	21.3	189.0	C	205.6	1.96	17.5	6.2	4.8	4	11	0.25	0.00022
GM060	7:1	720	7.1	63.0	21.3	189.0	D	410.2	3.92	35.0	25	19	2	5	0.25	0.00022
GM060	10:1	540	10.1	90.0	30.4	270.0	C	293.0	2.80	25.0	6.2	4.8	4	11	0.25	0.00022
GM060	10:1	500	10.1	90.0	30.4	270.0	D	586.0	5.60	50.0	25	19	2	5	0.25	0.00022

Note: Pole Count for GM060 is 6

Thermal Resistance for GM060 is 1.5 °C/W

Stator winding thermal resistance (winding to ambient) is for the unit, mounted to a 254mm x 254mm x 12.7mm (10in x 10in x 0.5in) aluminum plate.

(1) These specifications refer to the output of the GM assembly.

When programming a digital amplifier for use with a GM assembly, these specifications must be adjusted by the ratio to create actual motor performance

(2) Inertia = Motor Rotor + Gear Selection. External Inertia must be divided by the square of the ratio.

(3) Peak of sine wave

* For Motor Selection calculations see page 194

Specification are subject to change without notice



Stealth[®] GM Gearmotors Series: GM90 Speed / Torque Curves

Single Stack - 160 volt

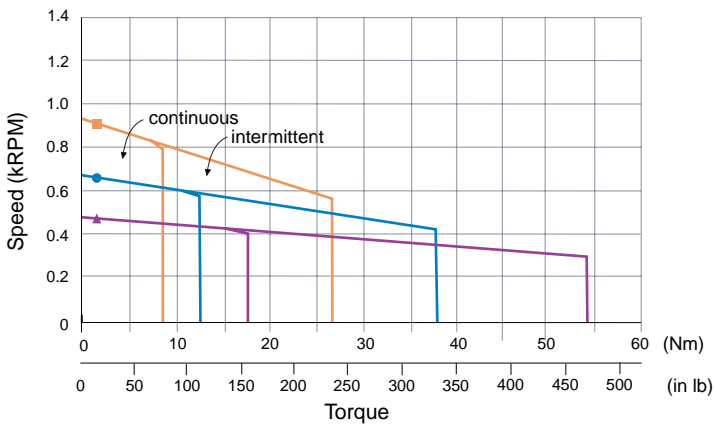

Single Stack - 300 volt

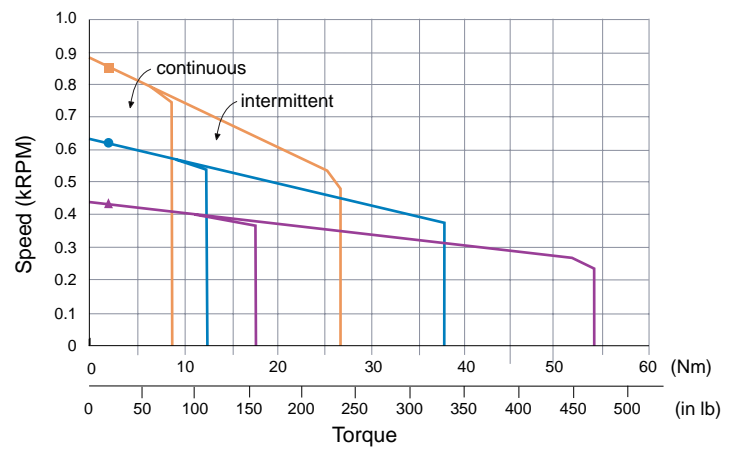

5:1 7:1 10:1

Double Stack - 160 volt

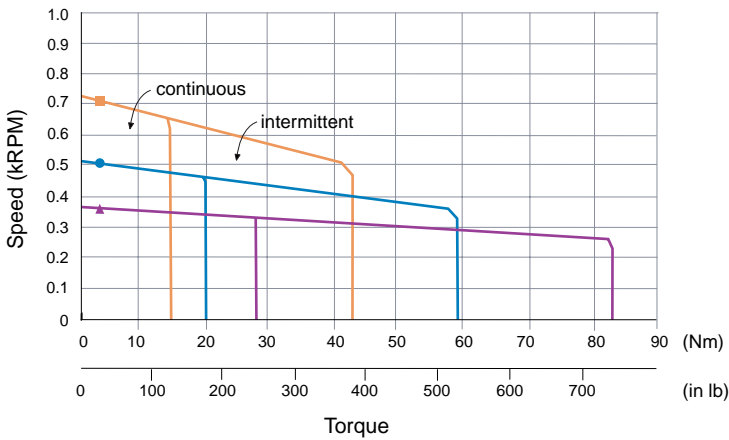

Double Stack - 300 volt

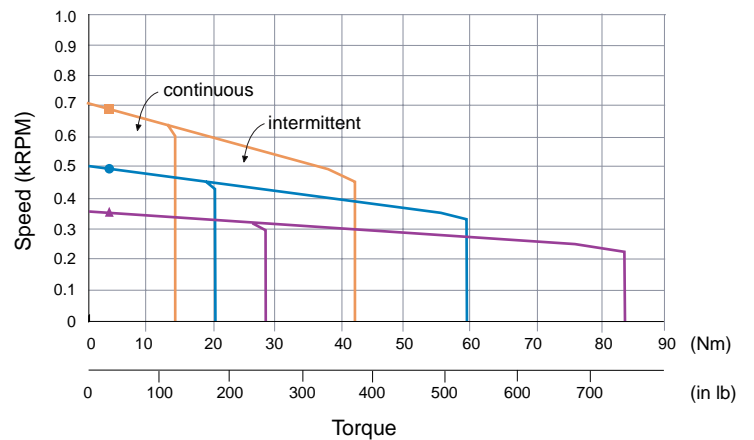

Stealth[®] GM Gearmotors Series: GM90



Performance Specifications (six step/trapezoidal commutation)

Mechanical Specifications

Frame Size	Stack Length	Weight without Brake		Maximum Radial Load		Torsional Stiffness		Standard Backlash (arc min)	Low Backlash (arc min)
		(kg)	(lb)	(N)	(lb)	(Nm/arc min)	(in lb/arc min)		
GM090	Single	6.0	13.2	2,600	584	11	87	15	10
GM090	Double	7.4	16.3	2,600	584	11	87	15	10

* Measured at 2% of rated torque

Single Stack Specifications

Frame Size	Ratio	Max. Speed ⁽¹⁾ (RPM)	Cont. Stall Torque ⁽¹⁾ T _C		Peak Torque ⁽¹⁾ T _P		Winding C:160 Vdc D:300 Vdc	Voltage Constant ⁽¹⁾⁽³⁾ K _{EL-L} (V/kRPM)		Torque Constant ⁽¹⁾⁽³⁾ K _{TL-L} (Nm/amp) (in lb/amp)		Induct L _{L-L} (mH)	Cold Resistance R _{L-L} (ohms)	Cont. Current I _C (amps)	Peak Current I _P (amps)	Inertia ⁽²⁾	
			(Nm)	(in lb)	(Nm)	(in lb)		(Nm/amp)	(in lb/amp)	(gm cm sec ²)	(lb in sec ²)						
GM090	5:1	900	8.7	77.0	26.0	231.0	C	170.5	1.65	14.5	4.5	2.5	5	16	1.16	0.00100	
GM090	5:1	870	8.7	77.0	26.0	231.0	D	341.0	3.25	29.0	18.1	10.1	3	8	1.16	0.00100	
GM090	7:1	670	12.0	107.0	36.1	321.0	C	238.7	2.31	20.3	4.5	2.5	5	16	0.94	0.00081	
GM090	7:1	620	12.0	107.0	36.1	321.0	D	477.9	4.55	40.6	18.1	10.1	3	8	0.94	0.00081	
GM090	10:1	450	17.2	153.0	51.7	459.0	C	341.0	3.30	29.0	4.5	2.5	5	16	0.94	0.00081	
GM090	10:1	430	17.2	153.0	51.7	459.0	D	682.0	6.50	58.0	18.1	10.1	3	8	0.94	0.00081	

Double Stack Specifications

Frame Size	Ratio	Max. Speed ⁽¹⁾ (RPM)	Cont. Stall Torque ⁽¹⁾ T _C		Peak Torque ⁽¹⁾ T _P		Winding C:160 Vdc D:300 Vdc	Voltage Constant ⁽¹⁾⁽³⁾ K _{EL-L} (V/kRPM)		Torque Constant ⁽¹⁾⁽³⁾ K _{TL-L} (Nm/amp) (in lb/amp)		Induct L _{L-L} (mH)	Cold Resistance R _{L-L} (ohms)	Cont. Current I _C (amps)	Peak Current I _P (amps)	Inertia ⁽²⁾	
			(Nm)	(in lb)	(Nm)	(in lb)		(Nm/amp)	(in lb/amp)	(gm cm sec ²)	(lb in sec ²)						
GM090	5:1	720	14.0	124.0	41.9	372.0	C	221.5	2.10	18.5	3.8	1.6	7	20	1.31	0.00113	
GM090	5:1	700	14.0	124.0	41.9	372.0	D	426.0	4.05	36.0	14.1	6.3	3	10	1.31	0.00113	
GM090	7:1	500	19.5	173.0	58.4	519.0	C	310.1	2.94	25.9	3.8	1.6	7	20	1.10	0.00094	
GM090	7:1	500	19.5	173.0	58.4	519.0	D	596.4	5.67	50.4	14.1	6.3	3	10	1.10	0.00094	
GM090	10:1	360	27.8	247.0	83.4	741.0	C	443.0	4.20	37.0	3.8	1.6	7	20	1.10	0.00094	
GM090	10:1	350	27.8	247.0	83.4	741.0	D	852.0	8.10	72.0	14.1	6.3	3	10	1.10	0.00094	

Note: Pole Count for GM090 is 8

Thermal Resistance for GM090 is 1.2 °C/W

Stator winding thermal resistance (winding to ambient) is for the unit, mounted to a 254mm x 254mm x 12.7mm (10in x 10in x 0.5in) aluminum plate.

(1) These specifications refer to the output of the GM assembly.

When programming a digital amplifier for use with a GM assembly, these specifications must be adjusted by the ratio to create actual motor performance

(2) Inertia = Motor Rotor + Gear Selection. External Inertia must be divided by the square of the ratio.

(3) Peak of sine wave

* For Motor Selection calculations see page 194

Specification are subject to change without notice



Stealth[®] GM Gearmotors Series: GM115 Speed / Torque Curves

Single Stack - 160 volt

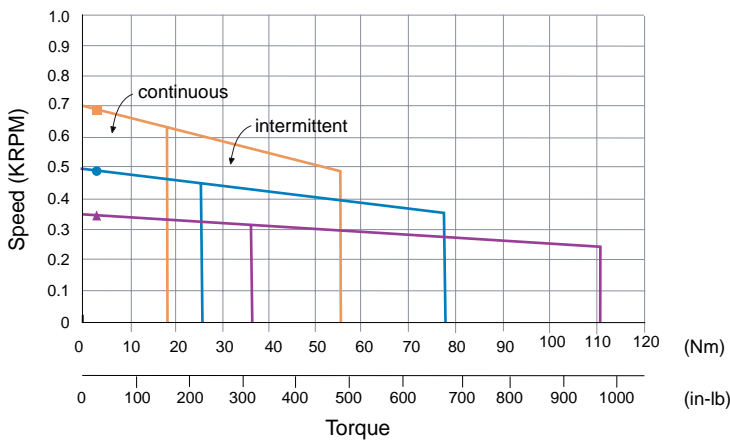

Single Stack - 300 volt

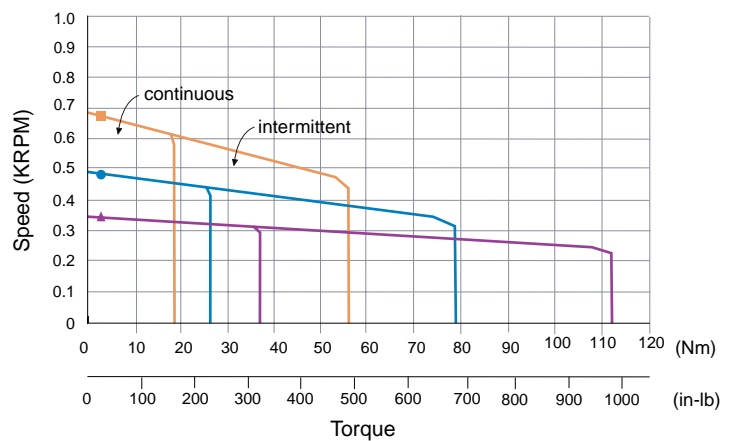

5:1 —■— 7:1 —●— 10:1 —▲—

Double Stack - 160 volt

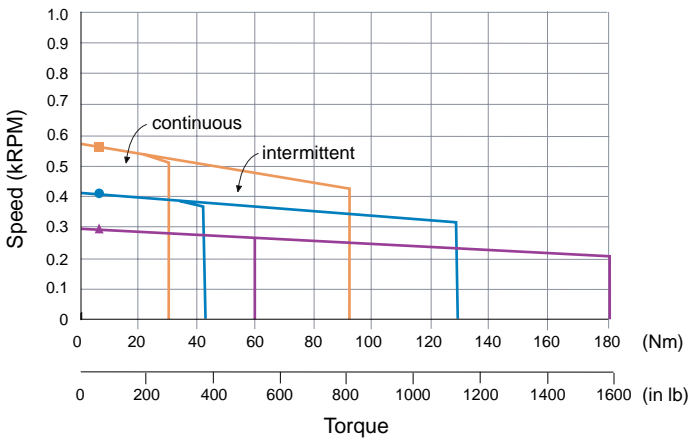

Double Stack - 300 volt

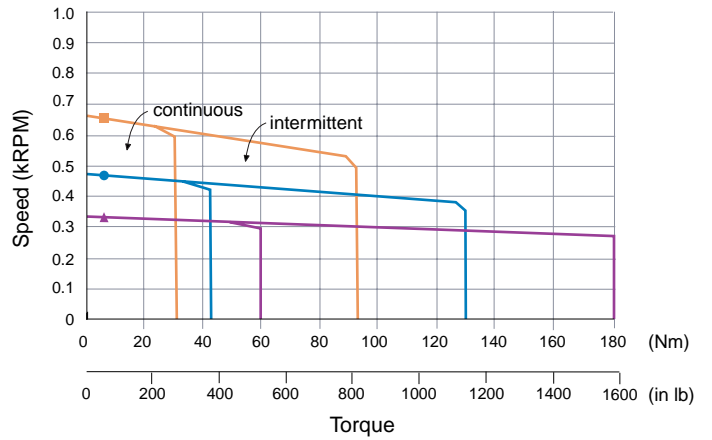

Stealth[®] GM Gearmotors Series: GM115



Performance Specifications (six step / trapezoidal commutation)

Mechanical Specifications

Frame Size	Stack Length	Weight without Brake		Maximum Radial Load		Torsional Stiffness		Standard Backlash (arc min)	Low Backlash (arc min)
		(kg)	(lb)	(N)	(lb)	(Nm/arc min)	(in lb/arc min)		
GM115	Single	8.4	18.5	3,900	876	20	177	15	10
GM115	Double	10.6	23.4	3,900	876	20	177	15	10

* Measured at 2% of rated torque

Single Stack Specifications

Frame Size	Ratio	Max. Speed ⁽¹⁾ (RPM)	Cont. Stall Torque ⁽¹⁾ T _C		Peak Torque ⁽¹⁾ T _P		Winding C:160 Vdc D:300 Vdc	Voltage Constant ⁽¹⁾⁽³⁾ K _{EL-L} (V/kRPM)	Torque Constant ⁽¹⁾⁽³⁾ K _{TL-L}		Induct L _{L-L} (mH)	Cold Resistance R _{L-L} (ohms)	Cont. Current I _C (amps)	Peak Current I _P (amps)	Inertia ⁽²⁾	
			(Nm)	(in lb)	(Nm)	(in lb)			(Nm/amp)	(in lb/amp)					(gm cm sec ²)	(lb in sec ²)
GM115	5:1	700	18.2	162	54.7	486	C	228.0	2.15	19.5	2.9	1.2	8	25	4.33	0.00375
GM115	5:1	680	18.2	162	54.7	486	D	438.0	4.15	37.0	10.7	4.7	4	13	4.33	0.00375
GM115	7:1	500	25.4	227	76.6	681	C	319.2	3.01	27.3	2.9	1.2	8	25	3.54	0.00306
GM115	7:1	480	25.4	227	76.6	681	D	613.2	5.81	51.8	10.7	4.7	4	13	3.54	0.00306
GM115	10:1	350	36.5	324	109.4	972	C	456.0	4.30	39.0	2.9	1.2	8	25	3.54	0.00306
GM115	10:1	340	36.5	324	109.4	972	D	876.0	8.30	74.0	10.7	4.7	4	13	3.54	0.00306

Double Stack Specifications

Frame Size	Ratio	Max. Speed ⁽¹⁾ (RPM)	Cont. Stall Torque ⁽¹⁾ T _C		Peak Torque ⁽¹⁾ T _P		Winding C:160 Vdc D:300 Vdc	Voltage Constant ⁽¹⁾⁽³⁾ K _{EL-L} (V/kRPM)	Torque Constant ⁽¹⁾⁽³⁾ K _{TL-L}		Induct L _{L-L} (mH)	Cold Resistance R _{L-L} (ohms)	Cont. Current I _C (amps)	Peak Current I _P (amps)	Inertia ⁽²⁾	
			(Nm)	(in lb)	(Nm)	(in lb)			(Nm/amp)	(in lb/amp)					(gm cm sec ²)	(lb in sec ²)
GM115	5:1	570	30.1	267	90.2	801	C	280.5	2.70	23.5	2.2	0.73	11	34	6.28	0.00544
GM115	5:1	650	30.1	267	90.2	801	D	455.5	4.35	38.5	5.8	1.9	7	21	6.28	0.0054
GM115	7:1	400	42.0	373	125.9	1,119	C	392.7	3.78	32.9	2.2	0.73	11	34	5.50	0.00475
GM115	7:1	470	42.0	373	125.9	1,119	D	637.7	6.09	53.9	5.8	1.9	7	21	5.50	0.00475
GM115	10:1	280	60.0	533	179.9	1,599	C	561.0	5.40	47.0	2.2	0.73	11	34	5.50	0.00475
GM115	10:1	320	60.0	533	179.9	1,599	D	911.0	8.70	77.0	5.8	1.9	7	21	5.50	0.00475

Note: Pole Count for GM115 is 12

Thermal Resistance for GM115 is 0.95 °C/W

Stator winding thermal resistance (winding to ambient) is for the unit, mounted to a 254mm x 254mm x 12.7mm (10in x 10in x 0.5in) aluminum plate.

(1) These specifications refer to the output of the GM assembly.

When programming a digital amplifier for use with a GM assembly, these specifications must be adjusted by the ratio to create actual motor performance

(2) Inertia = Motor Rotor + Gear Selection. External Inertia must be divided by the square of the ratio.

(3) Peak of sine wave

* For Motor Selection calculations see page 194

Specification are subject to change without notice



Stealth[®] GM Gearmotors Series

Dimensions

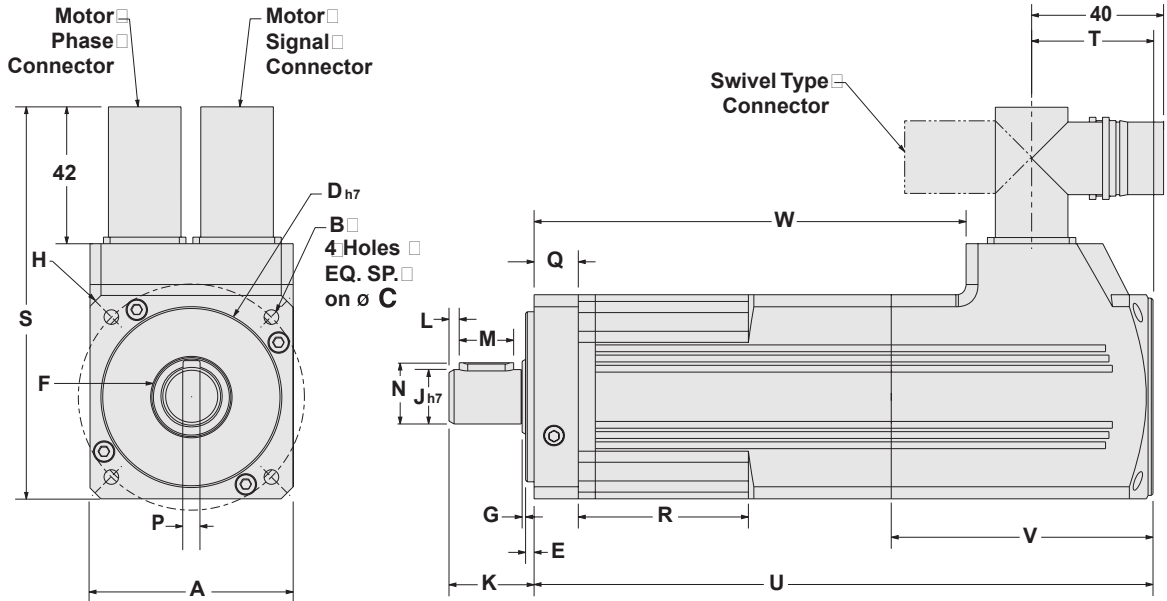

METRIC SIZES

Frame Size	A Square Flange		B Bolt Hole		C Bolt Circle Diameter		D Pilot Diameter		E Pilot Thick.		F Shoulder Diameter		G Shoulder Height		H Housing Diameter		J Shaft Diameter	
	(mm)	(in)	(mm)	(in)	(mm)	(in)	(mm)	(in)	(mm)	(in)	(mm)	(in)	(mm)	(in)	(mm)	(in)	(mm)	(in)
GM060	60	2.36	5.5	0.22	70	2.756	50	1.969	2.5	0.1	23	0.91	1.0	0.04	80	3.15	16	0.63
GM090	90	3.54	6.5	0.26	100	3.94	80	3.15	3.0	0.12	36	1.42	1.0	0.04	116	4.57	20	0.79
GM115	115	4.53	8.5	0.33	130	5.12	110	4.33	3.5	0.14	36	1.42	1.5	0.6	152	5.95	24	0.94

Frame Size	K Shaft Length		L Dist From Shaft End		M Keyway Length		N Keyway Height		P Keyway Width		Q Flange Thick.		R Recess Length		S Height		T Connector Location	
	(mm)	(in)	(mm)	(in)	(mm)	(in)	(mm)	(in)	(mm)	(in)	(mm)	(in)	(mm)	(in)	(mm)	(in)	(mm)	(in)
GM060	25.0	0.98	3	0.118	16	0.630	18.0	0.709	5	0.20	13	0.51	50.0	1.969	117	4.60	37	1.457
GM090	40.0	1.57	5	0.20	28	1.10	22.5	0.886	6	0.24	17	0.67	54.5	2.15	147	5.79	39	1.535
GM115	50.0	1.97	7	0.28	32	1.26	27.0	1.063	8	0.32	20	0.79	55.5	2.18	175	6.89	46	1.811

NEMA SIZES

Frame Size	B Bolt Hole		C Bolt Circle		D Pilot Diameter		J Output Shaft Diameter		K Output Shaft Length		M Keyway Length		N Keyway Height		P Keyway Width	
	(in)	(mm)	(in)	(mm)	(in)	(mm)	(in)	(mm)	(in)	(mm)	(in)	(mm)	(in)	(mm)	(in)	(mm)
GM023	0.195	5.0	2.625	66.7	1.500	38.1	0.375	9.5	1.000	25.4	0.750 flat	19.1 flat	0.015 flat	0.4 flat	—	—
GM034	0.218	5.5	3.875	98.4	2.875	73.0	0.500	12.7	1.250	31.8	1.063	27.0	0.072	1.8	0.125	3.2
GM042	0.281	7.1	4.950	125.7	2.187	55.5	0.625	15.9	1.500	38.1	1.130	28.7	0.108	2.7	0.188	4.8

Stealth[®] GM Gearmotors Series: Options



Options	U		V		W	
	Length		Rear Cover Length		Flange Offset	
	(mm)	(in)	(mm)	(in)	(mm)	(in)
GM060 Single Stack – Encoder or Resolver	178	7.01	70	2.76	121	4.76
GM060 Single Stack – Encoder or Resolver and Brake	203	7.99	95	3.74	143	5.63
GM060 Double Stack – Encoder or Resolver	216	8.5	70	2.76	159	6.26
GM060 Double Stack – Encoder or Resolver and Brake	241	9.46	95	3.74	181	7.12
GM090 Single Stack – Encoder or Resolver	202.3	7.96	83	3.27	143.3	5.64
GM090 Single Stack – Encoder or Resolver and Brake	230.3	9.07	111	4.37	171	6.73
GM090 Double Stack – Encoder or Resolver	240.4	9.46	83	3.27	181.4	7.14
GM090 Double Stack – Encoder or Resolver and Brake	268.4	10.57	111	4.37	209.1	8.23
GM115 Single Stack – Encoder or Resolver	207.2	8.16	70	2.76	147.3	5.8
GM115 Single Stack – Encoder or Resolver and Brake	240.2	9.46	103	4.06	170.3	6.7
GM115 Double Stack – Encoder or Resolver	245.3	9.66	70	2.76	185.4	7.3
GM115 Double Stack – Encoder or Resolver and Brake	278.3	10.96	103	4.06	208.4	8.2

Encoder Specifications (All GM Frame Sizes)

Resolution	2,000 Line (8,000 ppr)
Electrical Input:	5 Vdc, 125 ma maximum (plus interface loads)
Encoder Output:	A, B, I, \bar{A} , \bar{B} , \bar{I} Differential, TTL compatible Frequency Response 500 Khz

Resolver Specification (All Frame Sizes)

Frequency	Hz	5,000
Input Voltage	Vrms	4.0
Input Current	ma max.	23
Input Power	Watts nom.	0.045
Transformation Ratio	$\pm 10\%$	0.50
Output voltage	Vrms	2.0
Sensitivity	mv / Deg	35

Brake Specification

Frame Size	Static Holding Torque		Voltage (V)	Current (amps)	Resistance (ohms)	Inertia	
	(Nm)	(in lb)				(gm cm sec ²)	(oz in sec ²)
GM060	0.33	3.0	24 Vdc	0.19	131	4.32 x 10 ⁻⁸	6.0 x 10 ⁻¹⁰
GM090	5.64	50	24 Vdc	0.30	65	4.32 x 10 ⁻⁸	6.0 x 10 ⁻¹⁰
GM115	5.64	50	24 Vdc	0.30	65	2.5 x 10 ⁻⁷	3.5 x 10 ⁻⁹

Specification are subject to change without notice



Stealth[®] GM Gearmotors Series: Motor Connections & Cables

DIN Motor Power Connection

Pin Number	Function
3	U
1	V
4	W
2	Chassis Gnd.
A	Thermistor +
B	Thermistor -
C	Brake +
D	Brake -
-	Shield

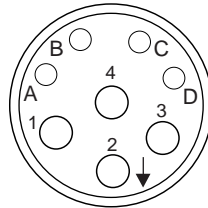

Power



Motor Power Mating Connector

Manufacturer	Part Number	Description
Hypertac	LPNA08BFRKB170	Body
	020.232.2000	4 Pins Female 18-26 AWG
	020.090.1020	4 Pins Female 16-20 AWG

Motor Power Cable

Part Number	Length	Used With
10963093	3 meter	Flying Leads
10963117	8 meter	Flying Leads

DIN Sensor Connector Details

Pin Number	Function		Mating Cable i-Drive Conn. Pin Number
	Encoder	Resolver	
1	A +	S1 (SIN+)	1
2	B +	S4 (COS+)	2
7	+5V	R2 (Ref+)	7
8	Shield	Shield	8
9	A -	S3 (SIN-)	9
10	B -	S2 (COS-)	10
15	Gnd	R1 (REF-)	15
12	Spare	Spare	—
5	I +	—	5
13	I -	—	13
3	Hall 1 (S1)	—	—
11	Hall 2 (S2)	—	—
4	Hall 3 (S3)	—	—
16	Thermistor +	Thermistor +	—
17	Thermistor -	Thermistor -	—
6 & 14	No Connection		—

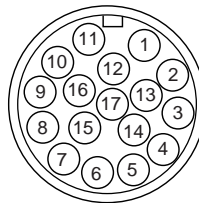

Sensor



Motor Sensor Mating Connector

Manufacturer	Part Number	Description
Hypertac	SPNA17HFRON	Body
	020.256.1020	17 Pins Female

Mating Sensor Cable

Part Number	Length	Used With
10963094	3 meter	Flying Leads
10963096	3 meter	i-Drive
10963123	8 meter	Flying Leads
10963118	8 meter	i-Drive
10963136 ⁽¹⁾	—	i-Drive / Controller

(1) NOTE: When an external controller is used in a closed loop mode an additional sensor cable, part number 10963136, is required.

Flying Leads from out of the Motor (All GM Frame Sizes)

Power

Function	Color Code
U	Red
V	Black
W	White
Ground	Green

Encoder

Function	Color Code
A-	White
A+	Brown
B-	Green
B+	Blue
I-	Yellow
I+	Orange
S2	Violet
S1	White / Brown
S3	White / Orange
+5V	Red
GND	Black
T1	White / Red
T2	White / Black



Motor Signal Timing (C/D winding) at motor connector

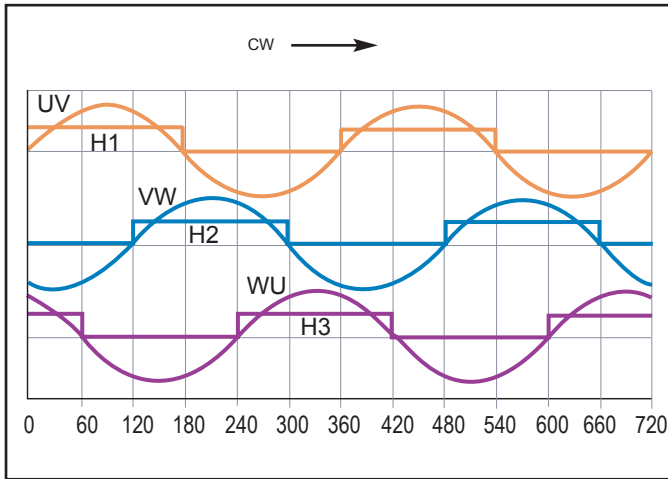

Encoder Timing

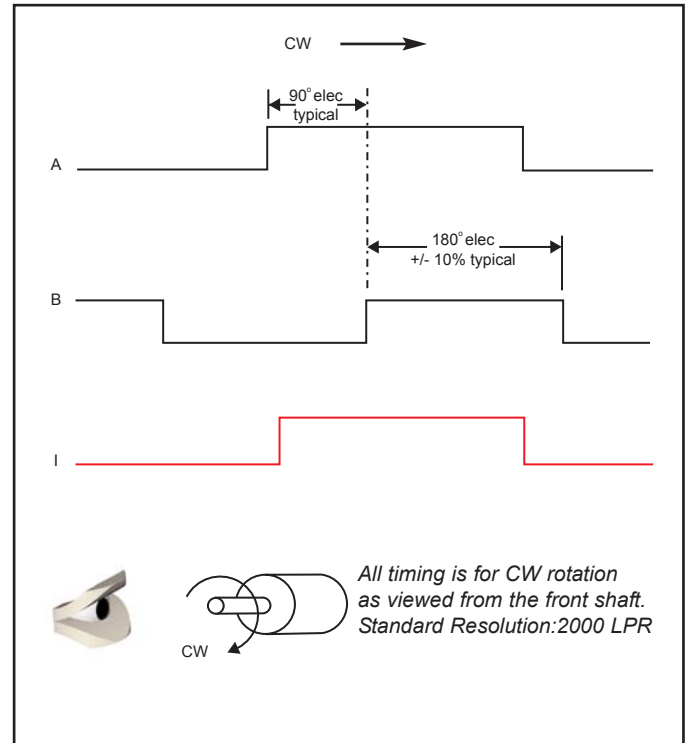

Specifications are subject to change without notice.

How to Order

Order Numbering Example: **G M 0 6 0 - B 1 C 1 D**

FRAME SIZE **RATIO** **STACK LENGTH** **WINDING** **OPTIONS** **CONNECTOR**

Metric **NEMA**
060 023
090 034
115 042

B = 5:1
C = 7:1
D = 10:1

1 = Single
2 = Double

C = 160Vdc
D = 300Vdc

1 = 2000 Line (1)
Encoder
2 = 2000 Line (1)
Encoder, Brake
3 = Resolver
4 = Resolver, Brake

B = MIL Connector
D = DIN Connector
F = Flying Leads (450mm/18in)

(1) Includes commutation signals

Gearmotors are supported by a worldwide network of offices and local distributors. Call **1-800-305-4555** for application engineering assistance or for the name of your local distributor. Information can also be obtained at www.baysidemotion.com.