



► *Frameless Motors* Series: Build Your Own High Performance Motor

When to Use:

- A significant cost savings
- Reduced mechanical complexity
- Greater design flexibility
- High performance in a compact package
- Improved dynamic response and settling
- Minimum motor size per application space
- Low cogging for smooth operation
- Low inertia for high acceleration

Applications:

- Automotive
- Machine Tool
- Material Handling
- Packaging
- Robotics
- Semiconductor

The frameless kit motors are ideal solutions for machine designs that require high performance in small spaces. The kit motors approach allow for direct integration with a mechanical transmission device, eliminating parts that add size and compliance. The use of frameless kit motors result in a smaller more reliable motor package.

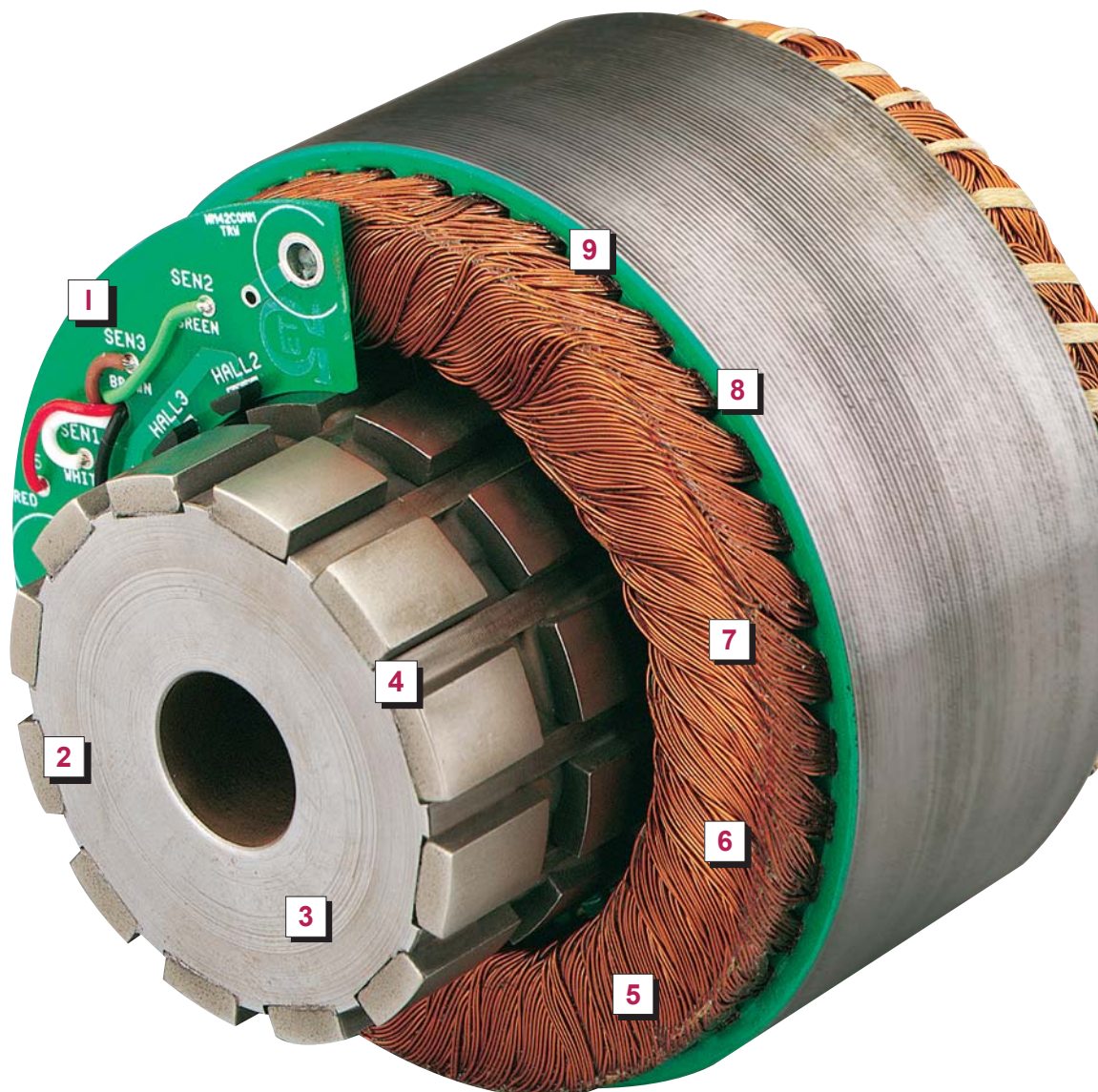



1 **Pre-installed Integral Commutation Board**
with Hall Effects is prealigned for easy assembly. Motor and feedback as integrated unit.

2 **Rare Earth Magnets**
provide high flux in a small volume, high resistance to thermal demagnetizing

3 **Rotor Assembly**
for easy mounting directly on the drive shaft with or without keyway.

4 **Machined Grooves**
to securely lock magnets to rotor and ensures optimized radial location.

5 **Class H Insulation**
for high temperature operation (up to 155°C) meeting UL approved requirements.

6 **High Density Copper Winding**
for low thermal resistance and consistent performance across all motors.

7 **Minimized End Turns**
to maximize performance. Formed to minimize motor size.

8 **Skewed Laminations**
with odd slot counts reduce cogging for precise rotary motion with drastically reduced torque ripple even at low speeds.

9 **Optimized Slot Fill**
for maximum torque-to-size ratio hand inserted to obtain highest slot fill possible maximizing ampere-turns.

What goes into our Frameless Kit Motors...

Our direct drive brushless kit motors consist of three components:

- ▶ The stator and winding
- ▶ The rotor with high energy product neodymium magnets
- ▶ Hall sensor device for motor commutation

What comes out of our Frameless Kit Motors...

- ▶ High Torque - from 0.06 Nm (0.5 in lb) to 9.7 Nm (85.6 in lb)
- ▶ High Speeds - up to 50,000 RPM
- ▶ Superior Performance - high stiffness and better response
- ▶ High Reliability - no mechanical transmission devices (couplings, flanges)
- ▶ Compact Design - minimizes product size
- ▶ Low Cogging - unique magnetic circuit design decreases cogging
- ▶ No RFI-EMI generation



Frameless Motors Series:

K032 to K0254 Motors

Performance Specifications (six step/trapezoidal commutation)

Frame Size	Stack Length		Continuous Torque ⁽¹⁾		Peak Torque		Motor Constant		Core Loss	Rotor* Inertia		Electrical Time Constant	Thermal Resistance	Weight	
	(mm)	(in)	T _C	T _p	T _C	T _p	K _m	P _C	J _m	T _C	W _m	(msec)	(°C/W)	(kg)	(oz)
			(Nm)	(oz in)	(Nm)	(oz in)	(Nm/√W)	(oz in/√W)	W @1kRPM	(gm cm sec ²)	(oz in sec ²)				
K032025	6.35	0.25	0.044	6.3	0.095	13.5	0.009	1.25	0.03	0.0016	0.000022	0.21	3.44	0.042	1.5
K032050	12.7	0.5	0.08	11.4	0.188	27	0.016	2	0.06	0.0032	0.000045	0.35	3.44	0.068	2.4
K032075	19.05	0.75	0.11	15.7	0.281	40	0.022	3	0.09	0.0048	0.000067	0.44	3.44	0.096	3.4
K032100	25.4	1	0.136	19.4	0.375	54	0.027	4	0.12	0.0064	0.000089	0.5	3.44	0.122	4.3
K032150	38.1	1.5	0.181	25.8	0.544	77.7	0.036	5.15	0.18	0.0096	0.000134	0.6	3.44	0.173	6.1
K032200	50.8	2	0.22	31.1	0.654	93.4	0.044	6.25	0.24	0.013	0.000178	0.66	3.44	0.26	9.2
K032300	76.2	3	0.33	46.5	0.99	139.5	0.054	7.56	0.36	0.0192	0.000268	0.7	3.44	0.36	12.8
K044025	6.35	0.25	0.119	17	0.357	50	0.02	3	0.11	0.0072	0.0001	0.39	2.36	0.085	3
K044050	12.7	0.5	0.214	30.6	0.642	90	0.035	5	0.24	0.014	0.0002	0.62	2.36	0.133	5
K044075	19.05	0.75	0.297	42.4	0.891	127	0.049	7	0.37	0.022	0.0003	0.76	2.36	0.200	7
K044100	25.4	1	0.364	52	1.092	156	0.06	9	0.49	0.03	0.00041	0.89	2.36	0.224	8
K044150	38.1	1.5	0.501	71	1.510	213	0.08	11.4	0.74	0.044	0.00061	1.05	2.36	0.311	11
K044200	50.8	2	0.607	86	1.820	258	0.097	13.8	1.11	0.06	0.00082	1.12	2.36	0.399	14.1
K044300	76.2	3	0.96	136.0	2.88	408	0.13	18.3	1.48	0.088	0.00122	1.3	2.36	0.549	19.4
K064025	6.35	0.25	0.31	44.3	0.93	133	0.048	6.88	0.37	0.046	0.00064	0.59	1.68	0.142	5
K064050	12.7	0.5	0.62	89	1.87	267	0.087	12.48	0.78	0.092	0.00128	0.98	1.68	0.286	10.1
K064075	19.05	0.75	0.85	121.7	2.56	365	0.122	17.44	1.19	0.138	0.00192	1.26	1.68	0.427	15.1
K064100	25.4	1	1.08	154	3.23	462	0.15	21.44	1.6	0.184	0.00256	1.47	1.68	0.572	20.2
K064150	38.1	1.5	1.46	209	4.39	627	0.204	29.12	2.37	0.276	0.00384	1.77	1.68	0.846	30.2
K064200	50.8	2	2.16	308	6.47	924	0.244	34.88	3.23	0.369	0.00512	1.97	1.68	1.129	40.3
K064300	76.2	3	2.91	410	8.73	1,230	0.33	46.6	4.74	0.552	0.00768	2.6	1.68	1.701	60.5
K089050	12.7	0.5	1.307	186.7	3.92	560	0.164	23.36	2.14	0.38	0.00528	1.26	1.02	0.498	17.6
K089075	19.05	0.75	1.96	280	5.88	840	0.235	33.6	3.35	0.576	0.008	1.64	1.02	0.747	26.4
K089100	25.4	1	2.618	374	7.84	1,120	0.283	40.64	4.42	0.792	0.011	1.92	1.02	0.996	35.2
K089150	38.1	1.5	3.92	560	11.76	1,680	0.381	54.4	6.7	1.15	0.016	2.33	1.02	1.494	52.8
K089200	50.8	2	4.291	613	12.87	1,839	0.466	66.56	8.95	1.51	0.021	2.6	1.02	1.992	70.4
K089300	76.2	3	7.13	1,004	21.4	3,012	0.631	88.9	13.4	2.30	0.032	2.9	1.02	3.00	105.6

(1) = Housed in a motor frame.

Typically an aluminum cylinder with 6.35mm (0.250in) thick walls,
 K032, K044 and K064 mounted to a 152mm x 152mm x 12.5 mm (6in x 6in x 0.5in) aluminum plate
 K089 mounted to a 203mm x 203mm x 12.5mm (8in x 8in x 0.5in) aluminum plate

* See Engineering Reference page 297 for inertia discussion.

Pole Count

K032 is 4
 K044 is 6
 K064 is 8
 K089 is 12



Frame Size	Stack Length		Continuous Torque ⁽¹⁾		Peak Torque		Motor Constant		Core Loss	Rotor* Inertia		Electrical Time Constant	Thermal Resistance	Weight	
	(mm)	(in)	T _c		T _p		K _m		P _c	J _m		T _c	(°C/W)	W _m	
			(Nm)	(oz in)	(Nm)	(oz in)	(Nm/√W)	(oz in/√W)		(gm cm sec ²)	(oz in sec ²)			(kg)	(oz)
K375050	12.7	0.5	1.715	245	5.14	734	0.153	21.8	1.2	0.324	0.0045	1.45	1.02	0.611	21.6
K375075	19.05	0.75	2.401	343	7.19	1,027	0.213	30.4	1.8	0.497	0.0069	1.9	1.02	0.917	32.4
K375100	25.4	1	3.003	429	9	1,286	0.267	38.1	2.4	0.655	0.0091	2.24	1.02	1.095	38.7
K375150	38.1	1.5	4.025	575	12.6	1,723	0.357	51	3.6	1.01	0.014	2.68	1.02	1.554	54.9
K375200	50.8	2	4.935	705	14.82	2,117	0.438	62.6	4.8	1.30	0.018	3.03	1.02	2.02	71.1
K375300	76.2	3	6.69	942	20.1	2,826	0.592	83.4	7.2	2.02	0.028	3.5	1.02	2.94	103.5
K127050	12.7	0.5	3.94	563	11.83	1,690	0.29	41.4	4.7	1.15	0.016	2.38	0.7	1.087	38.4
K127100	25.4	1	6.98	997	21.04	3,006	0.513	73.3	9.6	2.38	0.033	3.7	0.7	1.766	62.4
K127150	38.1	1.5	9.56	1,365	28.66	4,094	0.702	100.3	14.5	3.53	0.049	4.6	0.7	2.355	83.2
K127200	50.8	2	11.75	1,678	35.24	5,034	0.864	123.4	19.4	4.75	0.066	5.23	0.7	2.99	105.6
K127300	76.2	3	16.1	2,263	48.3	6,789	1.18	166.1	29.0	7.06	0.098	6.1	0.7	3.65	147.2
K500050	12.7	0.5	3.05	435	9.14	1,306	0.224	32	1.6	1.15	0.016	2.6	0.7	1.087	38.4
K500100	25.4	1	5.49	784	16.46	2,352	0.403	57.6	3	2.30	0.032	4.5	0.7	1.766	62.4
K500150	38.1	1.5	7.92	1,131	23.76	3,394	0.582	83.2	4.8	3.46	0.048	6	0.7	2.355	83.2
K500200	50.8	2	9.44	1,349	28.32	4,046	0.694	99.2	6.4	4.61	0.064	6.4	0.7	2.988	105.6
K500300	76.2	3	15.4	2,170	46.2	6,510	1.13	159.3	8.6	6.92	0.096	8.0	0.7	4.18	147.2
K178050	12.7	0.5	10.12	1,445	16.18	2,312	0.627	89.6	9.1	4.75	0.066	4.16	0.5	2.4	84.8
K178100	25.4	1	18.06	2,580	28.89	4,127	1.12	160	18.7	9.36	0.13	6.54	0.5	3.71	131.2
K178150	38.1	1.5	24.75	3,535	39.59	5,655	1.534	219	14.4	14.4	0.2	8.15	0.5	4.98	176
K178200	50.8	2	30.7	4,386	49.12	7,017	1.904	272	18.7	18.7	0.26	9.31	0.5	6.34	224
K178300	76.2	3	43.1	6,078	69.0	9,724	2.68	377	28.8	28.8	0.4	12.2	0.5	8.90	313.6
K700050	12.7	0.5	5.05	722	8.09	1,155	0.314	44.8	7.70	7.7	0.107	2.9	0.4	2.4	84.8
K700100	25.4	1	9.57	1,367	15.32	2,188	0.594	84.8	15.4	15.4	0.214	5	0.4	3.71	131.2
K700150	38.1	1.5	13.55	1,935	21.67	3,096	0.84	120	23.2	23.2	0.322	6.8	0.4	4.98	176
K700200	50.8	2	17.52	2,503	28.03	4,004	1.086	155.2	30.9	31	0.429	8.5	0.4	6.34	224
K700300	76.2	3	27.5	3,876	44.0	6,200	1.53	215	46.4	46.4	0.644	10.7	0.4	8.91	313.6
K254050	12.7	0.5	18.78	2,683	30.04	4,292	1.043	149	17.9	17.9	0.248	6.05	0.4	4.48	158.4
K254100	25.4	1	33.92	4,846	54.27	7,753	1.883	269	35.5	35.5	0.493	9.63	0.4	6.79	240
K254150	38.1	1.5	46.84	6,692	74.95	10,707	2.597	371	53.1	53.1	0.738	12.5	0.4	9.056	320
K254200	50.8	2	58.35	8,336	93.37	13,338	3.234	462	71.0	71	0.986	14.7	0.4	11.32	400
K254300	76.2	3	80.9	11,400	129.4	18,240	4.49	632	106.2	106	1.478	18.0	0.4	15.9	560

(1) = Housed in a motor frame. Typically an aluminum cylinder with 6.35mm (0.250in) thick walls, K375, K127 and K500 mounted to a 305mm x 305mm x 12.5mm (12in x 12in x 0.5in) aluminum plate. K178, K700 and K254 mounted to a 406mm x 406mm x 12.5mm (16in x 16in x 0.5in) aluminum plate. * See Engineering Reference page 297 for inertia discussion.

Pole Count:
K127 & K375 are 12
K700 & K500 are 8
K178 & K254 are 18



Frameless Motors Series: K032 to K0254 Motors

Dimensions

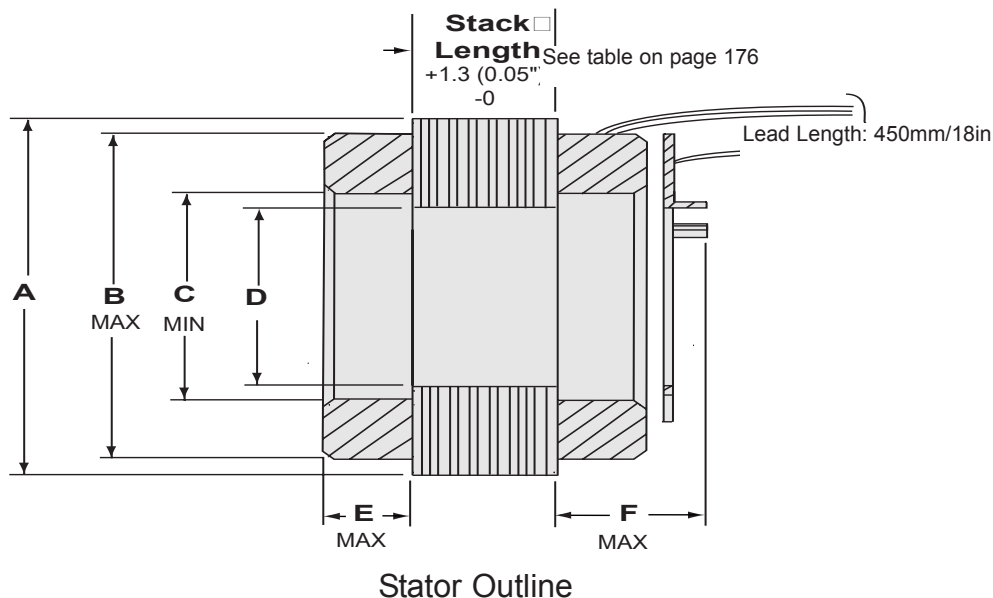

Frame Size	A O.D.		B End Turns O.D.		C End Turns I.D.		D I.D.		E End Turns Length		F Commutation Length	
	(mm)	(in)	(mm)	(in)	(mm)	(in)	(mm)	(in)	(mm)	(in)	(mm)	(in)
K032	31.78	1.251	27.94	1.1	16.51	0.65	15.06	0.593	6.4	0.25	14.5	0.57
	31.75	1.25					14.8	0.583				
K044	44.48	1.751	40.64	1.6	26.16	1.03	22.35	0.88	7.9	0.31	16.5	0.65
	44.42	1.749					22.09	0.87				
K064	63.52	2.501	60.7	2.39	38.1	1.5	35.18	1.385	9.65	0.38	17.5	0.69
	63.47	2.499					34.92	1.375				
K089	88.92	3.501	85.8	3.38	54.6	2.15	53.47	2.105	9.91	0.39	17.5	0.69
	88.87	3.499					53.21	2.095				
K375	95.28	3.751	88.9	3.5	53.32	2.06	50.93	2.005	12.7	0.5	19.5	0.77
	95.22	3.749					50.67	1.995				
K127	127.02	5.001	122.17	4.81	74.17	2.92	72.49	2.854	12.7	0.5	19.5	0.77
	126.97	4.999					72.23	2.844				
K500	127.05	5.002	115.32	4.54	70.6	2.78	68.2	2.685	20.5	0.81	30.5	1.2
	126.95	4.998					67.94	2.675				
K178	177.88	7.003	172.72	6.8	111.51	4.39	110.64	4.355	20.3	0.8	*	
	177.72	6.997					110.38	4.345				
K700	177.88	7.003	158.24	6.23	117.6	4.63	115.19	4.535	18.8	0.74	*	
	177.72	6.997					114.93	4.525				
K254	254.07	10.003	253.26	9.971	165.1	6.5	157.61	6.205	19.6	0.77	*	
	253.92	9.997					157.35	6.195				

*integral commutation not available

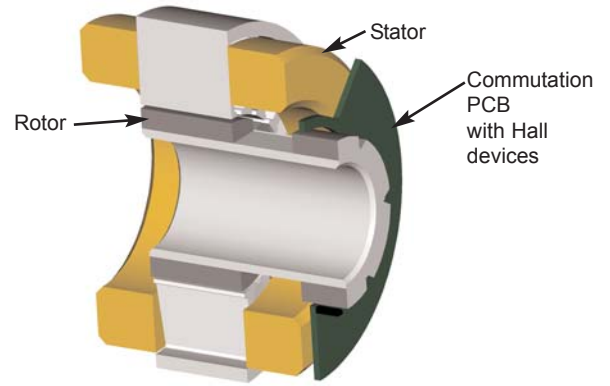
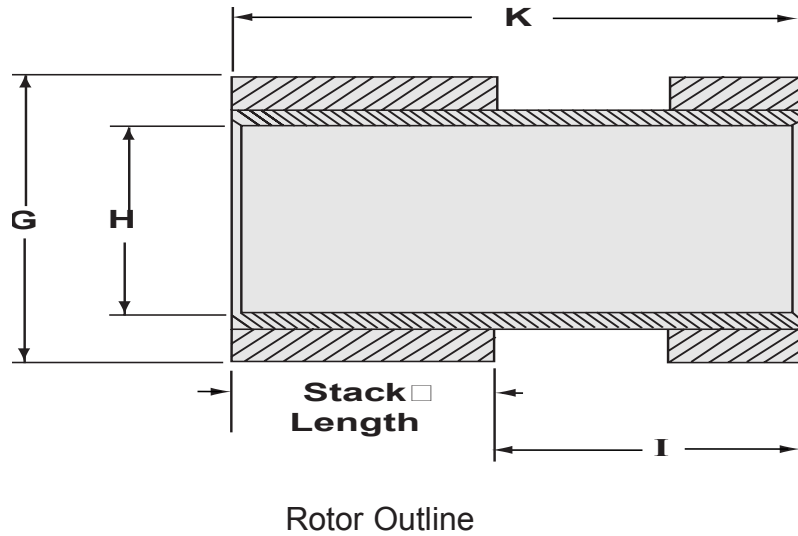

Figure 1.3
Kit Main Components

Frame Size	G Rotor O.D.		H Rotor I.D.		I Commutation Magnet Length		K Rotor Length
	(mm)	(in)	(mm)	(in)	(mm)	(in)	
K032	13.94	0.549	7.62	0.3	13.21	0.52	without Commutation: K = Stack Length + 0.76mm (0.030in)
	13.89	0.547	7.59	0.299			
K044	21.23	0.836	13.97	0.55	14.73	0.58	with Commutation: K = Stack Length + I + 0.76mm (0.030in)
	21.18	0.834	13.94	0.549			
K064	34.04	1.34	23.52	0.926	16.51	0.65	
	33.98	1.338	23.49	0.925			
K089	51.84	2.041	40.64	1.6	16.71	0.66	
	51.79	2.039	40.61	1.599			
K375	49.28	1.94	38.1	1.5	19.56	0.77	
	49.15	1.935	38.07	1.499			
K127	71.15	2.801	58.42	2.3	19.56	0.77	
	71.09	2.799	58.39	2.299			
K500	66.54	2.62	50.83	2.001	28.52	1.12	
	66.5	2.618	50.8	2			
K178	109.2	4.292	95.76	3.77	*		
	108.9	4.29	95.73	3.769			
K700	113.54	4.47	95.25	3.75	*		
	113.49	4.468	95	3.74			
K254	156.16	6.148	140.46	5.53	*		
	156.11	6.146	140.44	5.529			

*integral commutation not available



Frameless Motors Series: Winding Selection

The selection of a particular frame size and winding for an application is dependent on:

- Volume (diameter and length) requirement
- Power (torque and speed) requirement
- Voltage and current available or required

The first two items are dependent on the load and performance specifications of the application. They result in the selection of a particular frame size (032 through 254) and stack length.

The winding to be used will then be determined by voltage and current available or required.

Voltage: The bus voltage and maximum speed will determine the required voltage constant (K_E).

Current: The maximum load and acceleration will determine the amount of current required, determined by the torque constant (K_T) associated with the selected voltage constant.

Example: Assume a requirement of 1,000 RPM at 50 oz in

If a motor with a particular winding having $K_E = 18.24$ V/1,000 RPM and $K_T = 24.62$ oz in/amp is chosen, it will now require a voltage (BEMF) of 18 volts and current of 2 amp.

NOTE: K_E and K_T are directly proportional to each other. Increasing K_E will also increase K_T ; Decreasing K_E will also decrease K_T .

The result is that as the voltage requirement changes, the current requirement changes inversely.

Bayside has a range of **27** windings available for each frame size and stack length, providing for virtually any practical combination of voltage and current required for your application.

The following pages show just a small representative sample of speed/torque curves for each of the 10 frame sizes available.

For the 044, 064, 089 and 127 frame sizes, the speed/torque curves are for stators that are used in the standard BM / GM motor products.

They make a good starting point for determining your specific application requirements and working with Bayside application engineers to choose the proper motor size and power.

The following table lists the range of K_E and K_T available for each of the 10 frame sizes.

Detailed information for all these windings can be found on the web site: www.baysidemotion.com

Frame Size	Stack Range		K_E Range		K_T Range	
	(mm)	(in)	(V/1,000 RPM)	(V/rad/sec)	(Nm/amp)	(oz in/amp)
K032	6.35 to 50.8	0.25 to 2.00	0.14 to 65.52	0.0013 to 0.625	0.0013 to 0.625	0.18 to 88.45
K044	6.35 to 50.8	0.25 to 2.00	0.28 to 126.3	0.0027 to 1.2	0.0027 to 1.2	0.38 to 170.6
K064	6.35 to 50.8	0.25 to 2.00	0.66 to 291.8	0.0063 to 2.78	0.0063 to 2.78	0.89 to 394
K089	6.35 to 50.8	0.25 to 2.00	1.35 to 605	0.013 to 5.77	0.013 to 5.77	1.83 to 817
K375	6.35 to 50.8	0.25 to 2.00	1.27 to 566	0.012 to 5.40	0.012 to 5.40	1.71 to 765
K127	12.7 to 50.8	0.50 to 2.00	3.73 to 827	0.036 to 7.88	0.036 to 7.88	5.04 to 1116
K500	12.7 to 50.8	0.50 to 2.00	3.38 to 714	0.032 to 6.81	0.032 to 6.81	4.56 to 964
K178	12.7 to 50.8	0.50 to 2.00	8.26 to 1716	0.079 to 16.4	0.079 to 16.4	11.18 to 2,323
K700	12.7 to 50.8	0.50 to 2.00	4.14 to 872	0.039 to 8.31	0.039 to 8.31	5.59 to 1,177
K254	12.7 to 50.8	0.50 to 2.00	11.44 to 2,537	0.109 to 24.2	0.109 to 24.2	15.5 to 3,425

NOTE: Longer stacks and special windings are available. Call 1-800-305-4555

Frameless Motors Series: Speed/Torque Curves



K032150-7Y

$K_T = 0.051 \text{ Nm/amp}$ (7.19 oz-in/amp) $R_{T-T} = 2.05 \Omega$ $I_{\text{cont}} = 3.6 \text{ amp}$
 $K_E = 0.051 \text{ v/rad/sec}$ (5.32 V/kRPM) $L_{T-T} = 1.16 \text{ mH}$ $I_{\text{peak}} = 10.8 \text{ amp}$
 $E_{\text{BUS}} = 48 \text{ Vdc}$

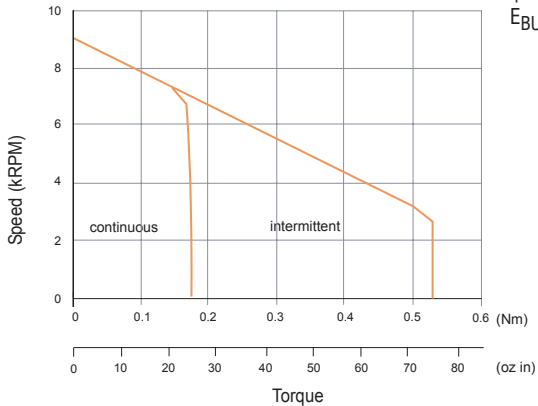

K044150-FY

$K_T = 0.28 \text{ Nm/amp}$ (39.6 oz-in/amp) $R_{T-T} = 11.8 \Omega$ $I_{\text{cont}} = 2 \text{ amp}$
 $K_E = 0.28 \text{ v/rad/sec}$ (29.3 V/kRPM) $L_{T-T} = 12.5 \text{ mH}$ $I_{\text{peak}} = 6 \text{ amp}$
 $E_{\text{BUS}} = 160 \text{ Vdc}$

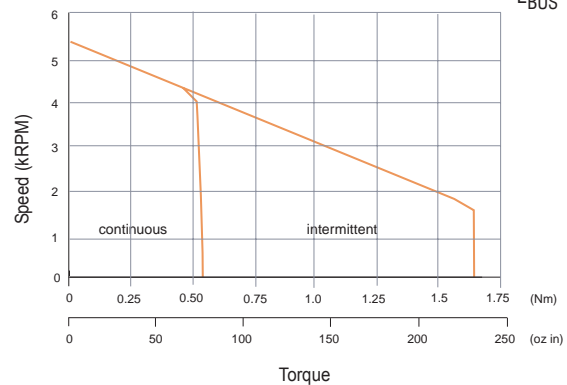

K044300-8Y

$K_T = 0.28 \text{ Nm/amp}$ (39.6 oz-in/amp) $R_{T-T} = 4.8 \Omega$ $I_{\text{cont}} = 3 \text{ amp}$
 $K_E = 0.28 \text{ v/rad/sec}$ (29.3 V/kRPM) $L_{T-T} = 6.2 \text{ mH}$ $I_{\text{peak}} = 9 \text{ amp}$
 $E_{\text{BUS}} = 160 \text{ Vdc}$

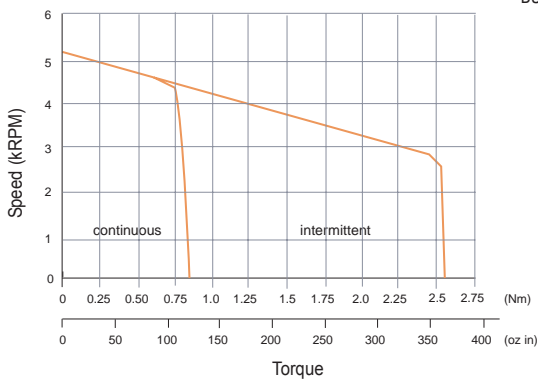

K064150-8Y

$K_T = 0.33 \text{ Nm/amp}$ (46.1 oz-in/amp) $R_{T-T} = 2.5 \Omega$ $I_{\text{cont}} = 6 \text{ amp}$
 $K_E = 0.33 \text{ v/rad/sec}$ (34.1 V/kRPM) $L_{T-T} = 4.5 \text{ mH}$ $I_{\text{peak}} = 18 \text{ amp}$
 $E_{\text{BUS}} = 160 \text{ Vdc}$

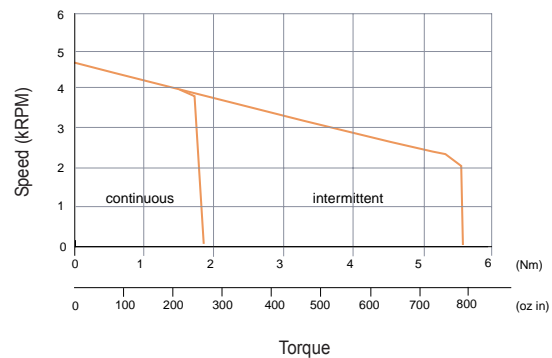

K064300-6Y

$K_T = 0.42 \text{ Nm/amp}$ (59.9 oz-in/amp) $R_{T-T} = 1.6 \Omega$ $I_{\text{cont}} = 7 \text{ amp}$
 $K_E = 0.42 \text{ v/rad/sec}$ (44.3 V/kRPM) $L_{T-T} = 3.8 \text{ mH}$ $I_{\text{peak}} = 21 \text{ amp}$
 $E_{\text{BUS}} = 160 \text{ Vdc}$

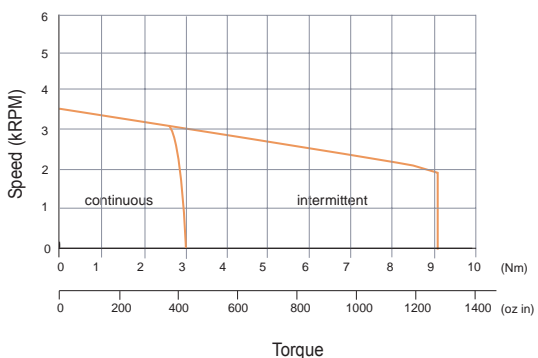

K375150-6Y

$K_T = 0.41 \text{ Nm/amp}$ (57.92 oz-in/amp) $R_{T-T} = 1.21 \Omega$ $I_{\text{cont}} = 10 \text{ amp}$
 $K_E = 0.41 \text{ v/rad/sec}$ (47.82 V/kRPM) $L_{T-T} = 3.45 \text{ mH}$ $I_{\text{peak}} = 30 \text{ amp}$
 $E_{\text{BUS}} = 160 \text{ Vdc}$

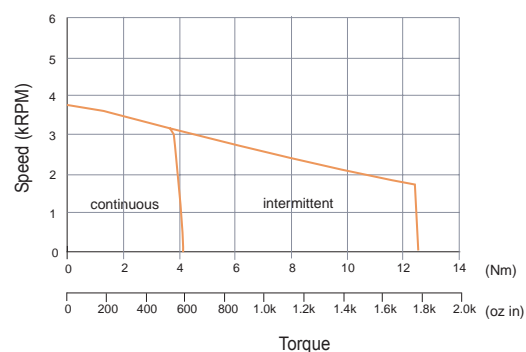



Frameless Motors Series: Speed/Torque Curves

K089150-6Y

$K_T = 0.43 \text{ Nm/amp}$ (61.6 oz-in/amp) $R_{T-T} = 1.2 \Omega$ $I_{cont} = 11 \text{ amp}$
 $K_E = 0.43 \text{ v/rad/sec}$ (45.6 V/kRPM) $L_{T-T} = 2.9 \text{ mH}$ $I_{peak} = 33 \text{ amp}$
 $E_{BUS} = 160 \text{ Vdc}$

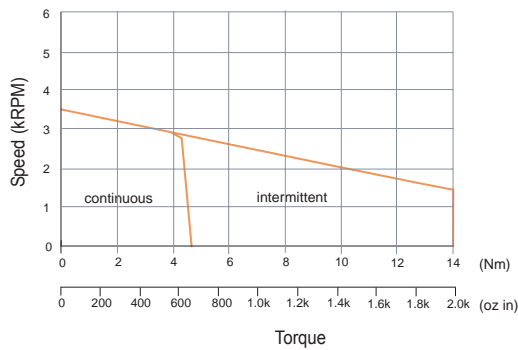

K089300-4Y

$K_T = 0.54 \text{ Nm/amp}$ (75.8 oz-in/amp) $R_{T-T} = 0.73 \Omega$ $I_{cont} = 15 \text{ amp}$
 $K_E = 0.54 \text{ v/rad/sec}$ (56.1 V/kRPM) $L_{T-T} = 2.2 \text{ mH}$ $I_{peak} = 45 \text{ amp}$
 $E_{BUS} = 160 \text{ Vdc}$

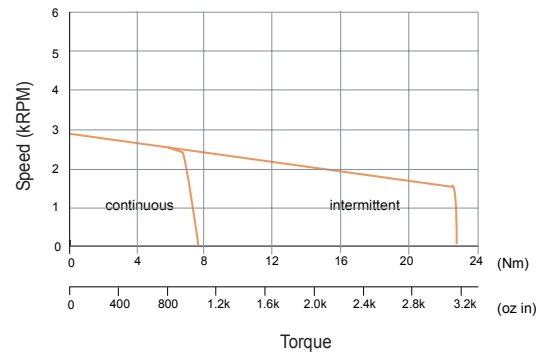

K127250-4Y

$K_T = 0.61 \text{ Nm/amp}$ (86.9 oz-in/amp) $R_{T-T} = 0.35 \Omega$ $I_{cont} = 20 \text{ amp}$
 $K_E = 0.61 \text{ v/rad/sec}$ (64.2 V/kRPM) $L_{T-T} = 2.1 \text{ mH}$ $I_{peak} = 60 \text{ amp}$
 $E_{BUS} = 300 \text{ Vdc}$

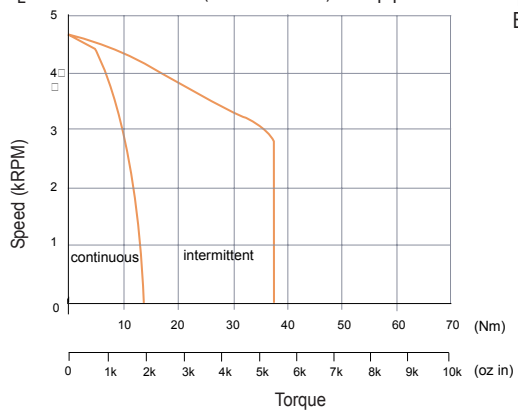

K127500-3Y

$K_T = 0.92 \text{ Nm/amp}$ (130.4 oz-in/amp) $R_{T-T} = 0.34 \Omega$ $I_{cont} = 24 \text{ amp}$
 $K_E = 0.92 \text{ v/rad/sec}$ (96.4 V/kRPM) $L_{T-T} = 2.3 \text{ mH}$ $I_{peak} = 72 \text{ amp}$
 $E_{BUS} = 300 \text{ Vdc}$

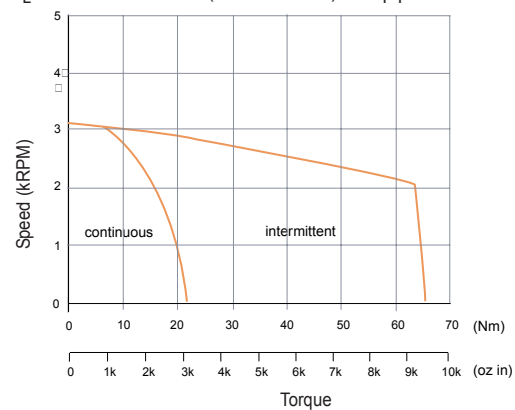

K500150-5Y

$K_T = 0.45 \text{ Nm/amp}$ (63.78 oz-in/amp) $R_{T-T} = 0.49 \Omega$ $I_{cont} = 18 \text{ amp}$
 $K_E = 0.45 \text{ v/rad/sec}$ (47.19 V/kRPM) $L_{T-T} = 2.72 \text{ mH}$ $I_{peak} = 53 \text{ amp}$
 $E_{BUS} = 300 \text{ Vdc}$

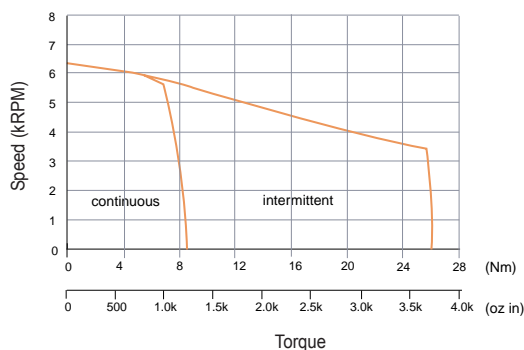

K178150-5Y

$K_T = 0.93 \text{ Nm/amp}$ (130.5 oz-in/amp) $R_{T-T} = 0.37 \Omega$ $I_{cont} = 27 \text{ amp}$
 $K_E = 0.93 \text{ v/rad/sec}$ (96.2 V/kRPM) $L_{T-T} = 2.95 \text{ mH}$ $I_{peak} = 43 \text{ amp}$
 $E_{BUS} = 300 \text{ Vdc}$

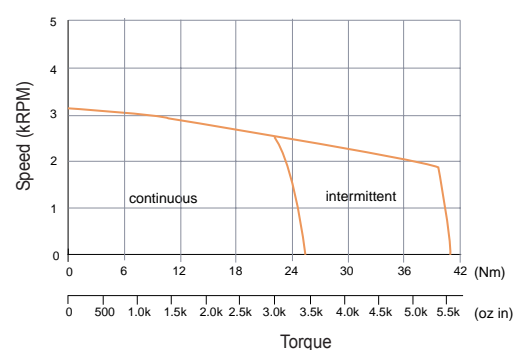

Frameless Motors Series: How to Order



K700150-7Y

$K_T = 0.78 \text{ Nm/amp}$ (110.35 oz-in/amp) $R_{T-T} = 0.84 \Omega$ $I_{\text{cont}} = 18 \text{ amp}$
 $K_E = 0.78 \text{ v/rad/sec}$ (81.71 V/kRPM) $L_{T-T} = 5.79 \text{ mH}$ $I_{\text{peak}} = 28 \text{ amp}$
 $E_{\text{BUS}} = 300 \text{ Vdc}$

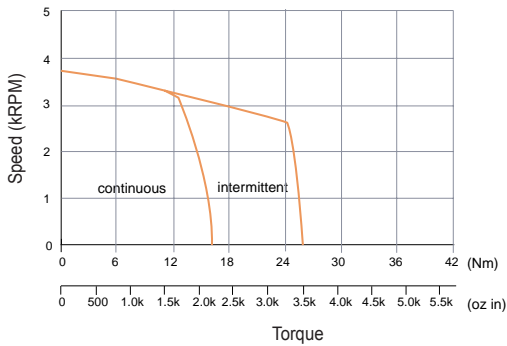

K254150-5Y

$K_T = 1.42 \text{ Nm/amp}$ (199.7 oz-in/amp) $R_{T-T} = 0.78 \Omega$ $I_{\text{cont}} = 34 \text{ amp}$
 $K_E = 1.42 \text{ v/rad/sec}$ (147.6 V/kRPM) $L_{T-T} = 3.6 \text{ mH}$ $I_{\text{peak}} = 54 \text{ amp}$
 $E_{\text{BUS}} = 300 \text{ Vdc}$

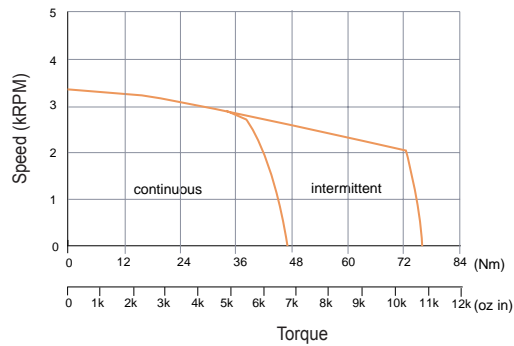

How to Order

Order
Numbering
Example:

K 0 4 4 1 0 0 - E Y 3

MODEL	STACK LENGTH	WINDING ⁽¹⁾	CONNECTION	COMMUTATION
032	025 (0.25")	1	Y	1 = Without
044	050 (0.50")	2		2 = With Integral
064	075 (0.75")	3		3 = With External ⁽²⁾
089	100 (1.00")	4		
375	150 (1.50")	5		
127	200 (2.00")	6		
500		7		
178		8		
700		9		
254		E		
		F		
		G		
		H		
		J		
		K		
		L		

- (1) Consult Bayside (1-800-305-4555 or www.baysidemotion.com) for specific winding designations.
 (2) For K178, K700 & K254 only

Bayside Kit Motors are supported by a worldwide network of offices and local distributors.
 Call 1-800-305-4555 for application engineering assistance or for the name of your local distributor.
 Information can also be obtained at www.baysidemotion.com.