



AB1A Driver Box User Manual

1st Edition April 2001

P/N :AB1A-458-000-A

Copyright

This document contains proprietary information of Nanomotion Ltd., and Nanomotion Inc., and may not be reproduced in any form without prior written consent from Nanomotion Ltd. and Nanomotion Inc.

Preface

Information in this document is subject to change without notice and does not represent a commitment on the part of NANOMOTION. No part of this document may be reproduced, translated, stored in a retrieval system or transmitted in any form and by any means, electronic, mechanical, photographic, photocopying, recording, or otherwise, without the written permission of NANOMOTION.

Copyright **April 2001**, Yokneam Israel. All rights reserved.

All products and company names are trademarks or registered trademarks of their respective holders.

About the User's Manual

This user manual provides information and instructing on how to operate the various AB1A configurations.

CE Compliance

The AB1A driver box complies with the European council directives:

EMC: Council directive 89/336/EEC:

Emissions Standard: EN 50081-2:1993 / EN 55011:1991

Conducted Emission class A

Radiated Emission class A

Immunity Standard: EN 50082-2:95

Electro Static Discharge (ESD) Standard: EN 61000-4-2:95

Radiated Immunity Standard: EN 61000-4-3:96 / ENV 50204:95

EFT (Electrical Fast Transients) Standard: EN 61000-4-4:95

Conducted Immunity Standard: EN 61000-4-6:96

Surges Standard: EN 61000-4-5:95

Voltage Variations Standard: EN 61000-4-11:94

SAFETY: council directive 73/23/EEC:

Safety: IEC 61010-1:1990

Table of Contents

CHAPTER 1: INTRODUCTION	1
1.1 General	1
1.2 Operating Principles	3
CHAPTER 2: CONNECTION INTERFACES	5
2.1 Front Panel Description	5
2.2 Analog Input Specifications	6
2.2.1 Opto-isolated Inputs	7
2.2.2 Fault Outputs.....	7
CHAPTER 3: INSTALLATION	8
3.1 Safety Warnings.....	8
3.2 External Power Supply Specifications	8
3.3 Cabling connections	9
3.4 Modifying the AB1A Box Configuration.....	9
3.4.1 Configuration Criteria	9
3.4.2 Opening the AB1A Box	10
3.4.3 AB1A Card Description	10
3.4.4 LC Card Type and Configuration	11
3.4.5 Voltage Source Configuration.....	12
3.5 Motor Connections	14
3.6 Before Operating the Motor	14
CHAPTER 4: ELECTRICAL INTERFACES	15
4.1 Connectors Descriptions	15
4.1.1 Control Terminal Description	15
4.1.2 Motor Output	16
4.1.3 I/O Port (Digital/Analog Control Interface)	17
4.2 System Interface	19
4.2.1 Single Ended Analog Interface	19
4.2.2 Differential Analog Interface	20
4.2.3 Joystick Interface.....	21

CHAPTER 5: APPENDIX 22

5.1 Specifications 22

5.2 Mechanical Dimensions..... 23

Chapter 1: Introduction

1.1 GENERAL

The AB1A is a single axis amplifier box designed to drive up to 32 motor elements in parallel.

The AB1A may be operated in one of two modes: *Velocity* mode in which the motor is driven continuously, or *Step* mode in which the driver output is turned OFF and ON at set intervals in order to drive the motor in discrete steps.

Step mode operation is illustrated in Figure 1, where the output is ON for 1/16 second at 0.5 second intervals. The amplitude of the output corresponds to the Analog input value and thus determines the speed of the motor.

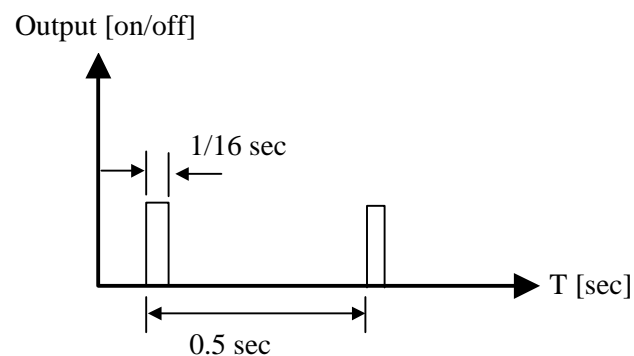

Figure 1: AB1A output in Step mode

AB1A Driver Box features:

High precision (11 bits) control of the output power stage

Drives up to 32 Nanomotion motor elements in parallel

“STEP mode” operation

Interfaces to an Analog command

Discrete inputs enable feedback from external sources such as limit switches, emergency stop command, etc.

Indicator LEDs

Output short circuit protection

Minimized sensitivity to cable length

Differential Heat Sensor input (option)

Master – Slave mode of operation (option)

Compact dimensions

1.2 OPERATING PRINCIPLES

The AB1A Driver Box contains the AB1A Card and an LC Card. The AB1A Card converts the analog input command signal into a corresponding PWM square wave output signal that is fed to the LC Card. The LC Card filters the signal to produce the output voltage that drives the motor.

The LC Card type corresponds to the number of motor elements to be used, and depending on the number of elements in the configuration, it may be either integrated internally or separately housed externally.

The required DC voltages are supplied by an internal DC-to-DC converter that is fed from an external +48V power supply.

The following figure shows a typical application.

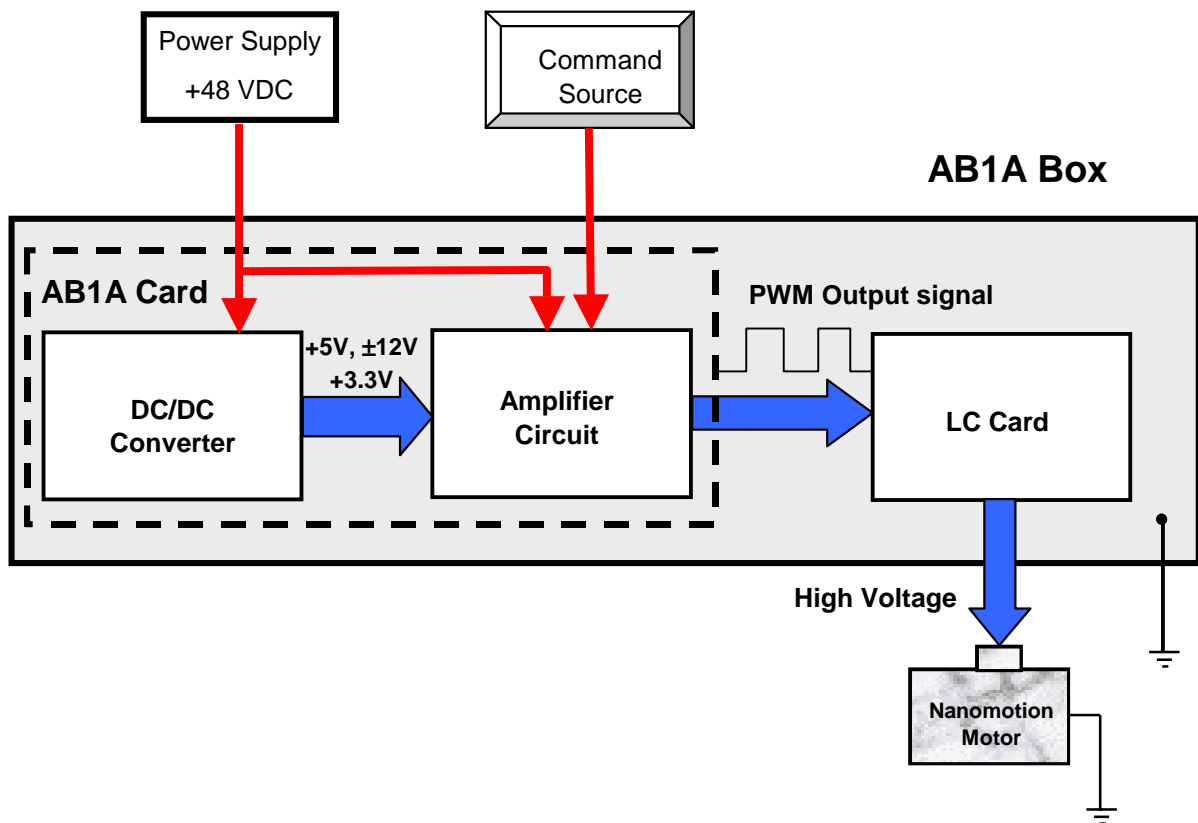

Figure 2: AB1A Block Diagram

The motor is a three-terminal component: "UP", "DOWN" and "COMMON." Voltage applied between the "UP" and the "COMMON" terminals causes the motor to move in one direction, while voltage applied between the "DOWN" and the "COMMON" terminals causes the motor to move in the opposite direction.

Below is a schematic drawing of the output stage.

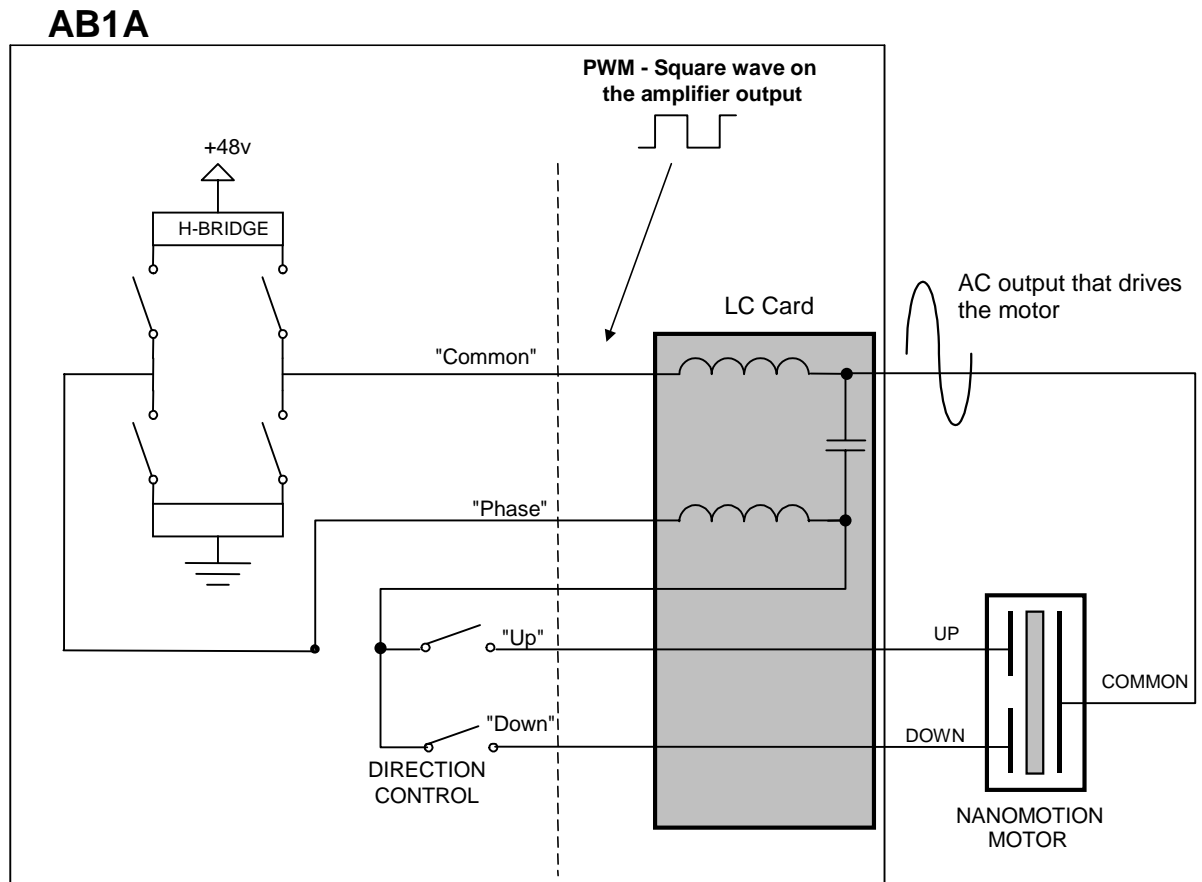

Figure 3: Schematic of the Output Stage with an internal LC Card

Chapter 2: Connection Interfaces

2.1 FRONT PANEL DESCRIPTION

All connections and indicators are located on the front panel. There are three connectors (Control Terminal, I/O Port, and Motor Out), and two indicators (Alarm 1, Alarm 2). The connectors and indicators are described in the following tables.

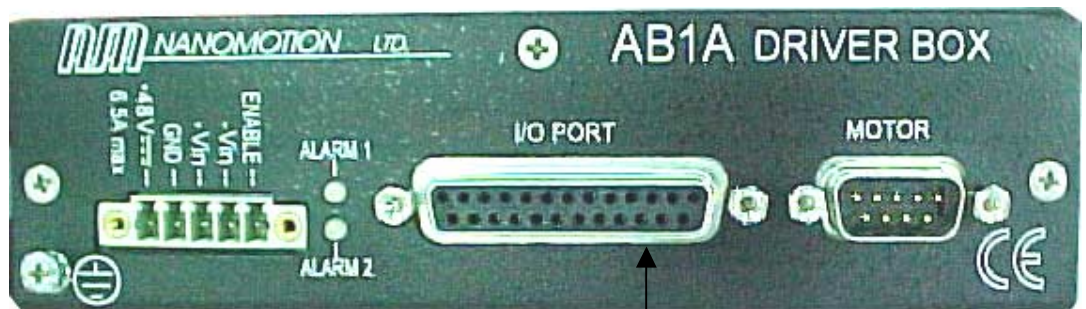

Figure 4: AB1A Box Front Panel

Control Terminal

Table 1: Front Panel Connectors

Connector	Description
Control terminal	<p>5 pin connector – Provides input from an external +48VDC power supply (6.5A max).</p> <p>Provides direct control of the motor ENABLE signal.</p> <p>Note: The motor may be operated with minimum control signals applied to the Control Terminal: +48V, GND POWER, VIN+, VIN-, ENABLE_IN. The primary voltage (+48V) is supplied from an external source.</p>
I/O Port	D-type 25 pin connector female - Interfaces to the control source (joystick or controller)
Motor Out	D-type 9 pin connector male -Interfaces to the motor.

Table 2: Front Panel Indicators

Condition	Alarm 1	Alarm 2
VCC < 4.6V	Off	Off
Motor Disconnected	Orange	Off
Motor Disable	Off	Orange
OK (Motor connected and enabled)	Green	Off
Over-current Protection	Red	Red

2.2 ANALOG INPUT SPECIFICATIONS

Analog input specifications

Signal type:	Differential or Single Ended
Input voltage range:	$\pm 10V$
Input impedance:	500K Ω
Input low pass filter:	Specific frequencies between 0.8KHz to 10KHz, according to configuration

Differential connection

This connection provides noise immunity.

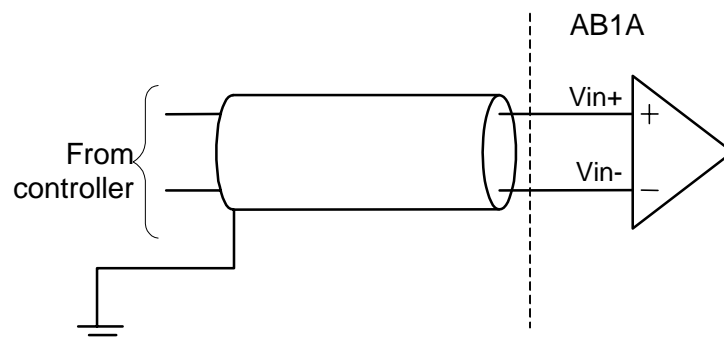

Figure 5: Differential Analog Input Connection

Single Ended connection

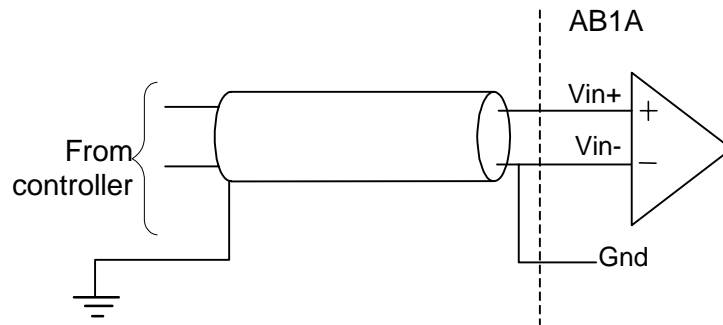

Figure 6: Non-Differential (single ended) Analog Input Connection.

2.2.1 Opto-isolated Inputs

The following input interfaces are opto-isolated and are activated by shorting them to ground:

- **Emergency Stop (ES).** Disables the AB1A output.
- **Enable.** Should be enabled *before* the motor is activated.
- **In Mode.** Enables Step Mode operation when activated.
- **Left Limit.** When activated, it disables motor motion to the left.
- **Right Limit.** When activated, it disables motor motion to the right.

2.2.2 Fault Outputs

Fault : An open collector output that is active (shorted to ground) under the following conditions:

The card is disabled by the Over Current Protection circuit.

The motor is not connected and the “Motor Disconnect” signal is floating.



NOTE: The Fault output is capable of sinking a maximum of 20mA, and is not protected from over current.

Chapter 3: Installation

3.1 SAFETY WARNINGS



WARNINGS:

Output voltage is 280Vrms max. Only authorized personnel may handle the AB1A Driver Box.

Be sure to disconnect all connectors and cables to the AB1A box before removing the cover.

3.2 EXTERNAL POWER SUPPLY SPECIFICATIONS

AB1A power consumption without motor: +48VDC/125mA

Supply Voltage	Current consumption	Usage
+48v ±5%	200mA max.	When 1x HR1 is connected.
	500mA max.	When 1x HR2 is connected.
	800mA max.	When 1x HR4 is connected.
	1200mA max.	When 1x HR8 is connected.



NOTE: *The required power supply value should be calculated by adding the total power consumption of all the motors that are connected to the AB1A power consumption without motor (+48VDC/125mArms) according to the following:*

$I = 125\text{mA} + n \cdot (\text{current consumption of single motor})$

$n = \text{Number of motors that are connected (n= 1/2/3/4)}$

3.3 CABLING CONNECTIONS

Connect the following groups of cables together, isolating each of the signals.

POWER SUPPLIES - use 22 AWG wires (or lower AWG) for the power supplies. For noisy surroundings, it is recommended to twist the *ground* line and the *power* line together.

ANALOG Command – a twisted shielded cable is recommended.

DISCRETE INPUTS - These signals are not sensitive to noise and can be grouped together in the same harness with any of the other groups.

SHIELDING- Since the high motor voltage is induced placed on the cable shield, it is required to make a good ground connection to the shield on both sides. The driver card and the motor should be grounded to the infrastructure earth.

3.4 MODIFYING THE AB1A BOX CONFIGURATION

To adjust the AB1A Box according to your configuration criteria (section 3.4.1), it may be necessary to open the unit (section 3.4.2), and make some changes on the AB1A Card (3.4.2).

3.4.1 Configuration Criteria

Below is a list of the criteria that may affect the card configuration:

- Changing the type of motor or the number of motor elements in your configuration requires changing the LC Card type and possibly its configuration (section 3.4.4)
- Changing the voltage source from an internal (default) to an external source, or vice versa, requires the LC Card to be configured accordingly (section 3.4.5).

3.4.2 Opening the AB1A Box

To open the AB1A Driver Box:

1. **Be sure all connections are removed from the AB1A box.**
2. Remove the six screws that secure the AB1A top cover, and set the top cover aside. The AB1A boards and components are exposed.
3. Make the necessary modifications.
4. Reassemble the cover.
5. Replace labels on the AB1A front panel under the "Motor Out" connector to indicate the type motor that should be connected.
6. Reconnect cables and test the AB1A Box operation.

3.4.3 AB1A Card Description

The AB1A Card (Figure 7) consists of DC/DC converters that provide the voltages necessary to operate the amplifier circuit: +5V, $\pm 12V$, +3.3V. In addition, the card contains two indicator LED's and the external interface connectors for the INPUT, MOTOR, and I/O signals.

The system configuration may call for a LC Card that is connected either internally to the AB1A Card, or externally in a separate LC Box. If the LC Card connection is *external*, then it is required to connect an adapter card to the AB1A Card (as illustrated in the figure below). The adapter card shorts the necessary pins to enable the connection of the external LC Card.

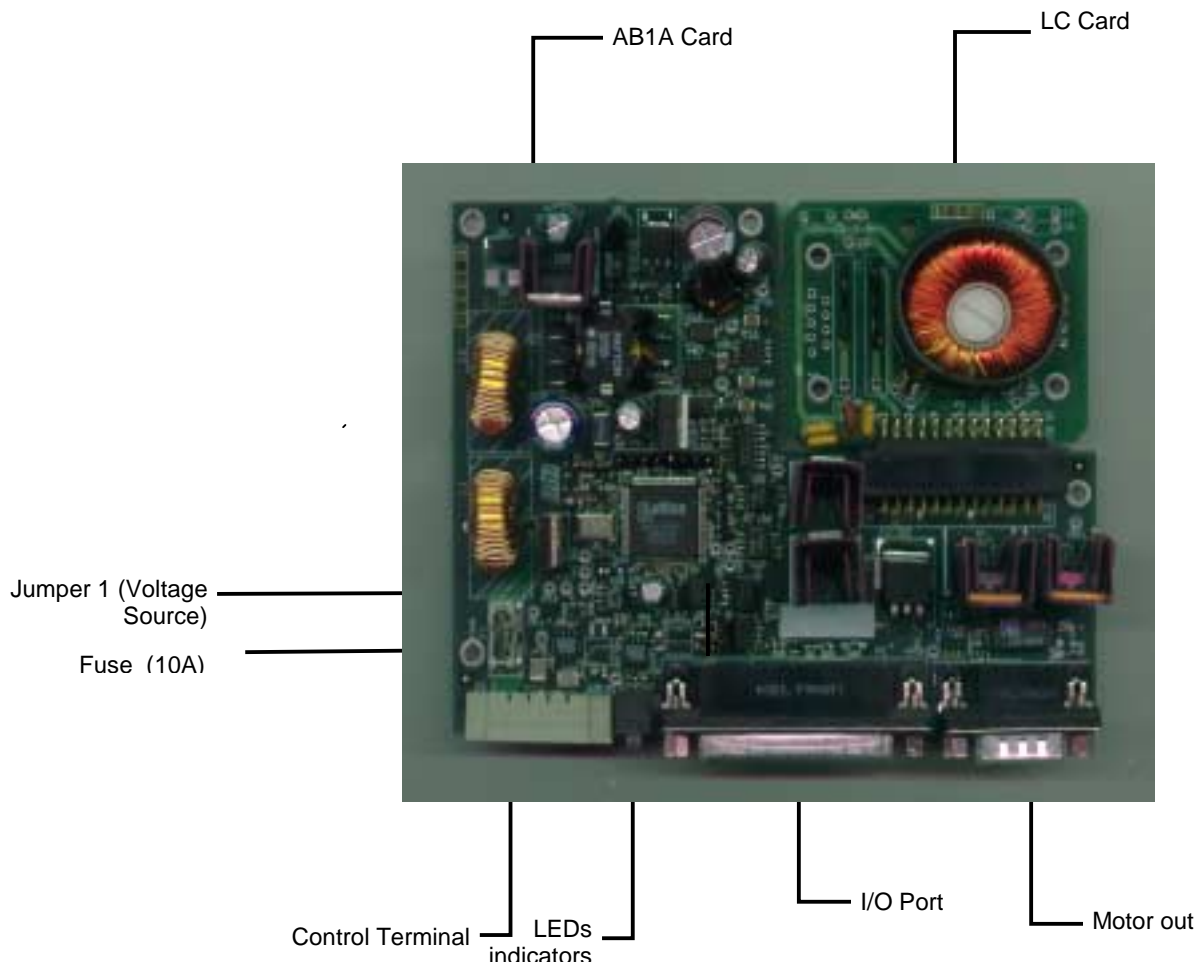

Figure 7: AB1A Card

3.4.4 LC Card Type and Configuration

The LC Card type and configuration depends on the number of motor elements driven.

For 1 to 16 elements, the LC circuit is internal to the AB1A (LC card).

For 32 elements, the LC circuit is external to the AB1A (LC box).

Each LC Card type is specifically designed to support a specific number of elements (please see Table 3 below).

NUMBER OF ELEMENTS	C2	C3	C4	INDUCTOR	TOTAL CABLE LENGTH ^(**)
1	Not connected	Not connected	0.22nF	8.5mH	0.1 – 5 m
2	Not connected	Not connected	2.2nF	3.7mH	0.1 – 5 m
4	Not connected	Not connected	4.7nF	1.84mH	0.1 – 10 m
8	5.6nF	Shorted	5.6nF	0.8mH	0.1 – 10 m
16	Shorted	4.7nF 4.7nF ^(*)	2.2nF 5.6nF ^(*)	0.48mH	0.1 – 10 m
32	2 External LC boxes, one for each 16 elements				0.4 – 40 m

^(*) Two capacitors in parallel .

^(**) Nanomotion Standard Motor Cable.

Table 3: LC Circuit Components for Standard Applications

Replacing an internal LC Card

To replace an internal LC Card with an external one, it is first required to remove the internal LC Card and replace it with the appropriate adapter (see Section 3.4.3 AB1A Card Description).



NOTE: Either an internal LC Card or an adapter must be connected to the internal LC connector.

3.4.5 Voltage Source Configuration

The opto-isolated input signals (2.2.1) are activated as short-to-ground. The voltage for the opto-isolated circuit (see Figure 9) is provided by either the internal +5V supply (default state) or an external voltage supply via pin 20 on the I/O Port connector. The circuit is then closed by an **Input Command** shorted to ground.

Configure **Jumper 1** (located near U1) on the AB1A Card according to the voltage source:

- Pin 1 shorted to Pin 2, for an internal +5V source (factory setting)
- Pin 2 shorted to Pin 3, for an external voltage source

 **ATTENTION:** Be sure that you do not short Pin 1 to Pin 3 on Jumper 1. Doing so will short the external power supply to the +5V supply! The input circuit is limited to sink up to 10mA but not less than 3mA.



Internal voltage source

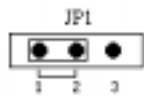

External voltage source



Figure 8: Jumper 1 Configuration.

The connections are shown in the following figure.

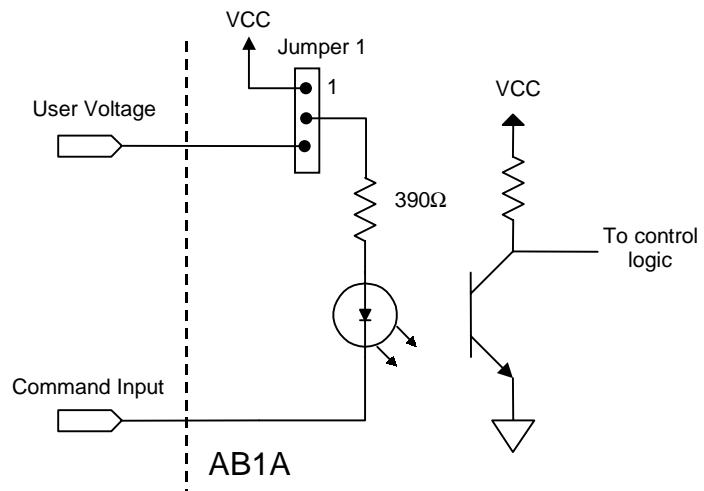

Figure 9: Opto-Isolated inputs interface.

3.5 MOTOR CONNECTIONS

The “Motor Disconnect” signal is available only at the motor connector, where it is shorted to ground. This ensures that unprotected motor pins will not be exposed to high voltage when the motor is not connected.

If more than one motor is connected to the AB1A Driver Box, it is required to use a suitable branch cable.



ATTENTION:

If you change the motor type, it may also be necessary to change the LC Card type. Consult NANOMOTION for the appropriate LC Card for your motor(s).

For proper operation, use only LC Card or boxes and branch cables supplied by NANOMOTION Ltd. Do not change the cable length without first consulting Nanomotion’s technical support. (For further information refer to the specific motor manual).

3.6 BEFORE OPERATING THE MOTOR

Before operating the AB1A please verify the following:

The correct internal/external LC Card is installed (section 3.4.4).

Jumper JP1 is set to the required mode of operation (section 3.4.5)

The box is tightly closed by the 6 screws.

The correct label indicating motor type is affixed to the box.

All connectors are locked by screws.

The external power supply is capable of supplying the required power consumption of the AB1A (Section 3.2)

There is no command when switching the power to “ON”

Make sure that all motors that are to be driven by the AB1A are preloaded.



ATTENTION: *The command should be limited according to the envelope of performance of the motor. Refer to the Motor User Manual.*

Chapter 4: Electrical Interfaces

4.1 CONNECTOR DESCRIPTIONS

4.1.1 Control Terminal Description

Table 3: Control Terminal Pin Description

Pin	Signal Name	Type
1	+48V	+48VDC POWER SUPPLY
2	GND	GROUND
3	VIN+	ANALOG INPUT
4	VIN-	ANALOG INPUT
5	ENABLE_IN	ENABLE INPUT



NOTE: Signals +VIN and -VIN and ENABLE_IN are identical in the I/O port (Table 5) and in the Control Terminal block (Table 3). The appropriate 5 pin female connector is supplied by Nanomotion for easy cable interface.

4.1.2 Motor Output

Table 4: Motor Out Port Description

Pin	Signal Name	Function	Description
1	GND	Power supply ground	Shorted to shield
2	Motor_Phase	48V PWM signal	For an external LC Box, connected to the capacitor in the LC Box; otherwise not connected.
3	Motor_Up	48V PWM signal	Connected to the motor 'UP' terminal.
4	Motor Common	48V PWM signal	Connected to the motor 'COMMON' terminal.
5	Motor_Down	48V PWM signal	For an external LC Box, connected to the inductor in the LC Box; otherwise not connected.
6	Motor Connected	Opto-coupled	Safety input, connected to ground via short on the motor connector to enable motor operation.
7	GND	Power supply ground	Shorted to shield
8	Motor in	High sine wave signal	For an external LC Box connected to the AC switch circuit
9	N.C	NOT INUSE	Option

4.1.3 I/O Port (Digital/Analog Control Interface)

Table 5: I/O Port Pin Description

Pin	Name	Description
1	VIN+	Positive analog command input
2	GND	Ground
3	FAULT	Open collector output
4	GND	Ground
5	NOT IN USE	--
6	DIRECTION*	TTL input (option)
7	- HEAT_SENSOR	Optional
8	SYNC_OUT	Optional
9	GND	Ground
10	LEFT_LIMIT*	Digital Input For Left Limit Switch – Active Low
11	-12V*	-12v Power Supply For External Device
12	EMERGENCY_STOP*	Protection Input – Active Low
13	USER_VOLTAGE*	External power supply for the opto-isolated type inputs.
14	VIN-	Negative analog command input
15	GND	Ground
16	STEP_MODE*	Mode Selection
17	RESET_IN	System initialization
18	NOT IN USE	--
19	NOT IN USE	--
20	+ HEAT_SENSOR	Optional
21	SYNC_IN	Optional
22	RIGHT_LIMIT*	Digital Input For Left Limit Switch - Active Low
23	+12V*	+12V Power Supply For External Device
24	ENABLE_IN*	Digital Input - Active Low
25	+5V*	+5V Power Supply For External Device



***NOTE.** Further explanations for some of the above signals are given in the following table.

Descriptions of the Control Interface signals

Signal	Description
Limit Switches	<p>The AB1A has two opto-isolated limit switch inputs ('Left Limit' and 'Right Limit'). These inputs turn the motor off when the mechanical element driven by the motor reaches the end motion.</p> <p>When the limit switch is active (shorted to ground), the motion in the corresponding direction is disabled, and only motion in the other direction is possible.</p>
Step_Mode	Determines the AB1A mode of operation (Velocity or Step Mode).
Emergency_Stop	Safety input. This opto-isolated input disables the card output when activated.
Enable_In	Control input. Enables box operation when shorted to ground.
-12V	Accessory voltage use for powering external component max 700mW. Ground is at the GND pin.
+12V	Accessory voltage use for powering external component max 700mW. Ground is at the GND pin.
+5V	Accessory voltage use for powering external component max 7.5W. Ground is at the GND pin.
DIRECTION	TTL input signal - determines the motor direction when using the AB1A with a specific external controller

4.2 SYSTEM INTERFACE

This section describes the pin interfaces for Analog, Differential, and Joystick inputs.

4.2.1 Single Ended Analog Interface

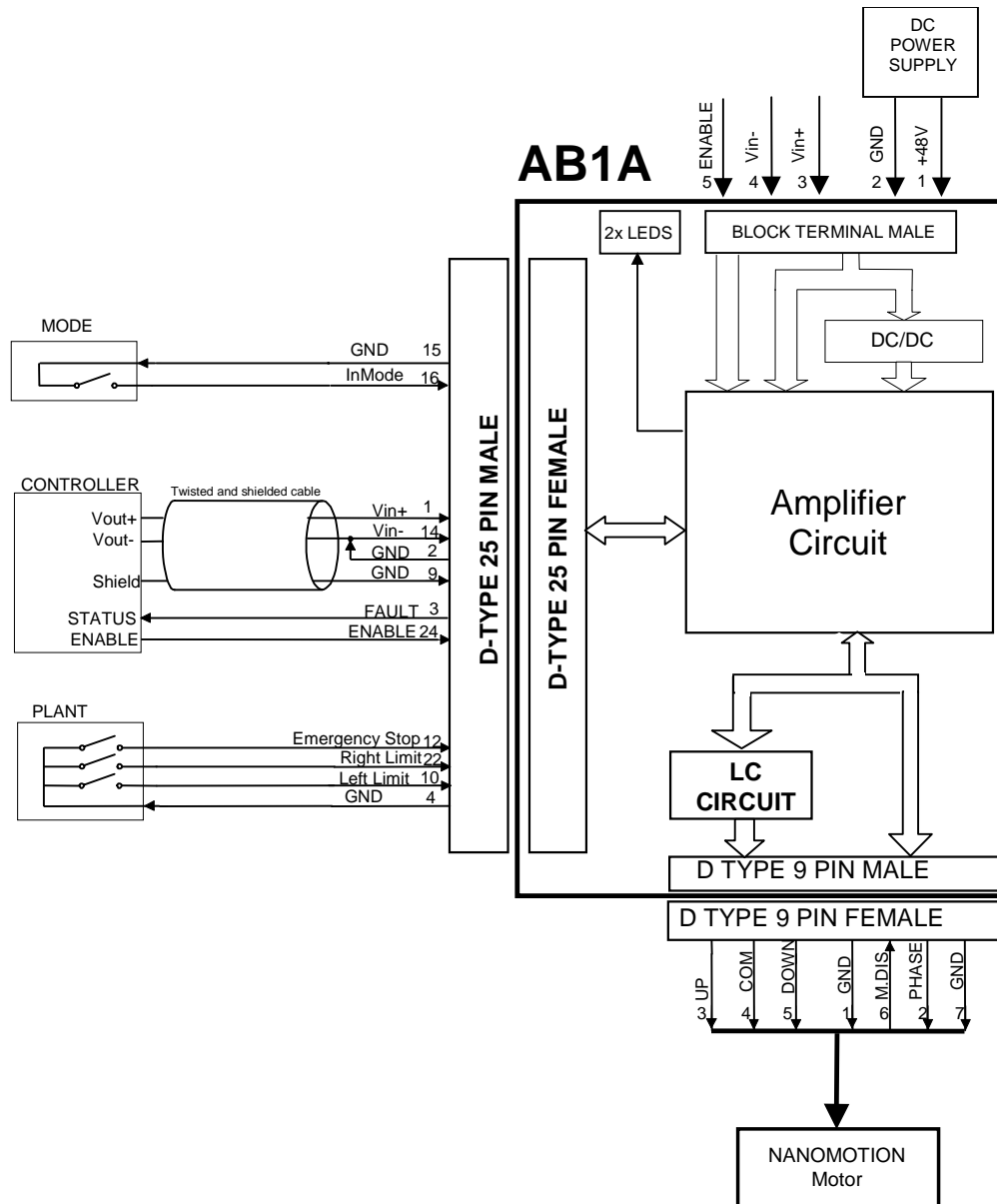

Figure 10: Non-differential (common) Input Interface

4.2.2 Differential Analog Interface

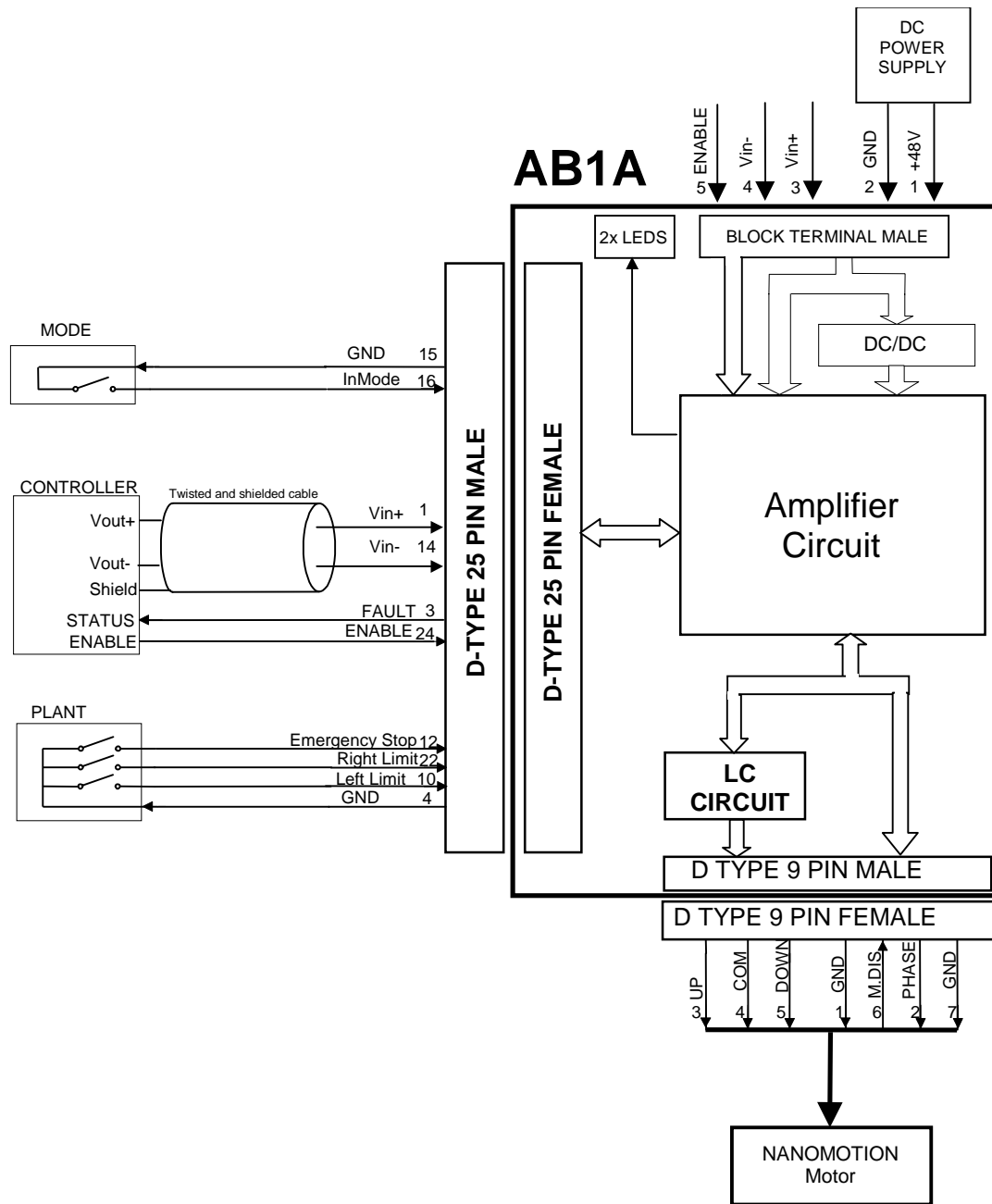

Figure 11: Differential Interface

4.2.3 Joystick Interface

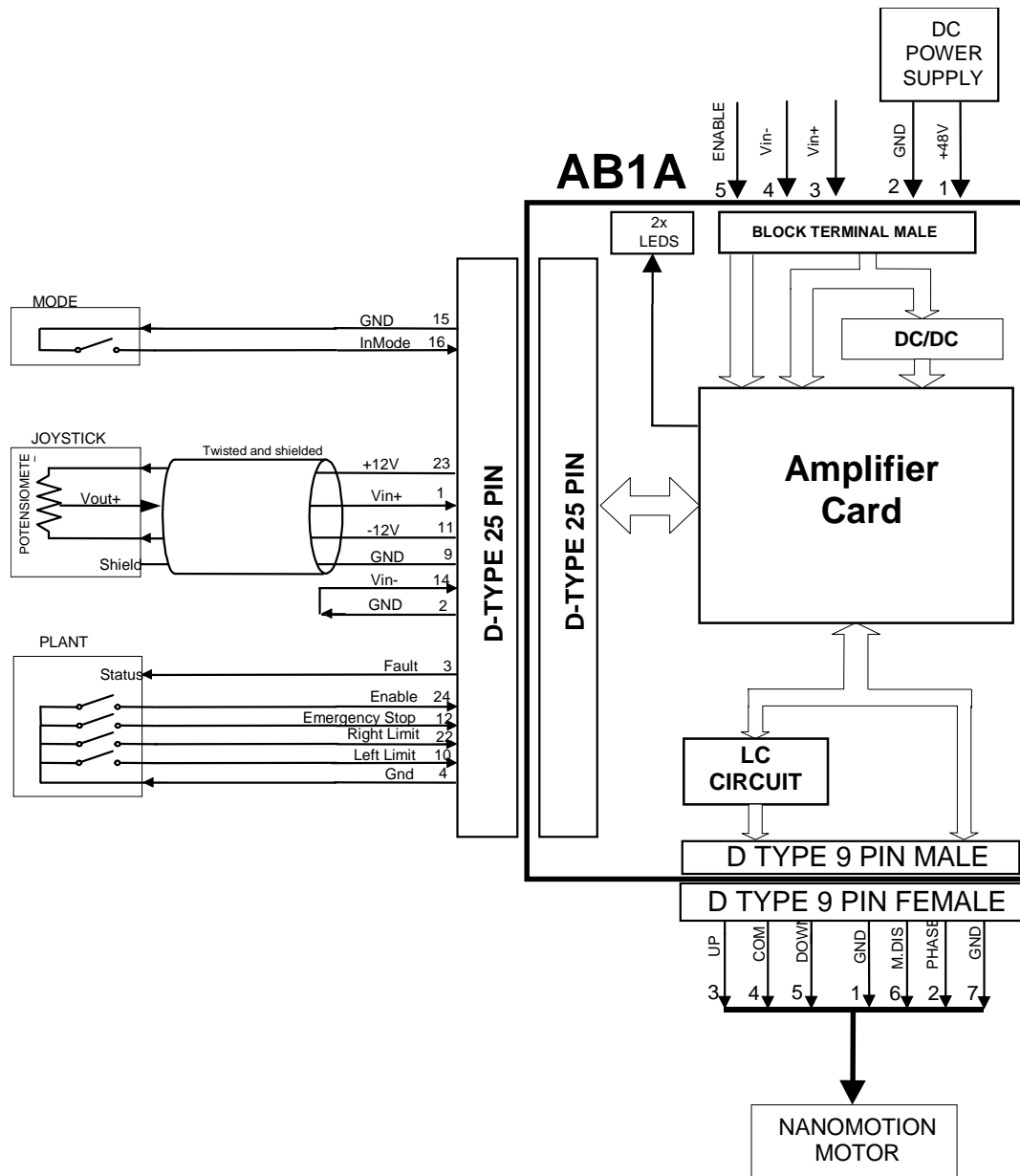

Figure 12: Joystick Interface

Chapter 5: Appendix

5.1 SPECIFICATIONS

Electrical specifications

Power Input	+48VDC \pm 5%
Max Motor Output	250-290Vrms
Power Consumption without Load	+48VDC/0.125A
Power Consumption with Max load	+48VDC/6.5Amax

Physical dimensions

Mechanical Dimensions (WxDxH)	149x118.5x41 (without mounting bracket)
Weight	450 gr.
Mounting options	Desk top / Wall mount

Environmental Specifications

Operating Temperature	0°C to 50°C
Storage Temperature	-40 to 70°C
Operating Humidity	Up to 80%

5.2 MECHANICAL DIMENSIONS

The following figure describes the dimensions of the AB1A Box.

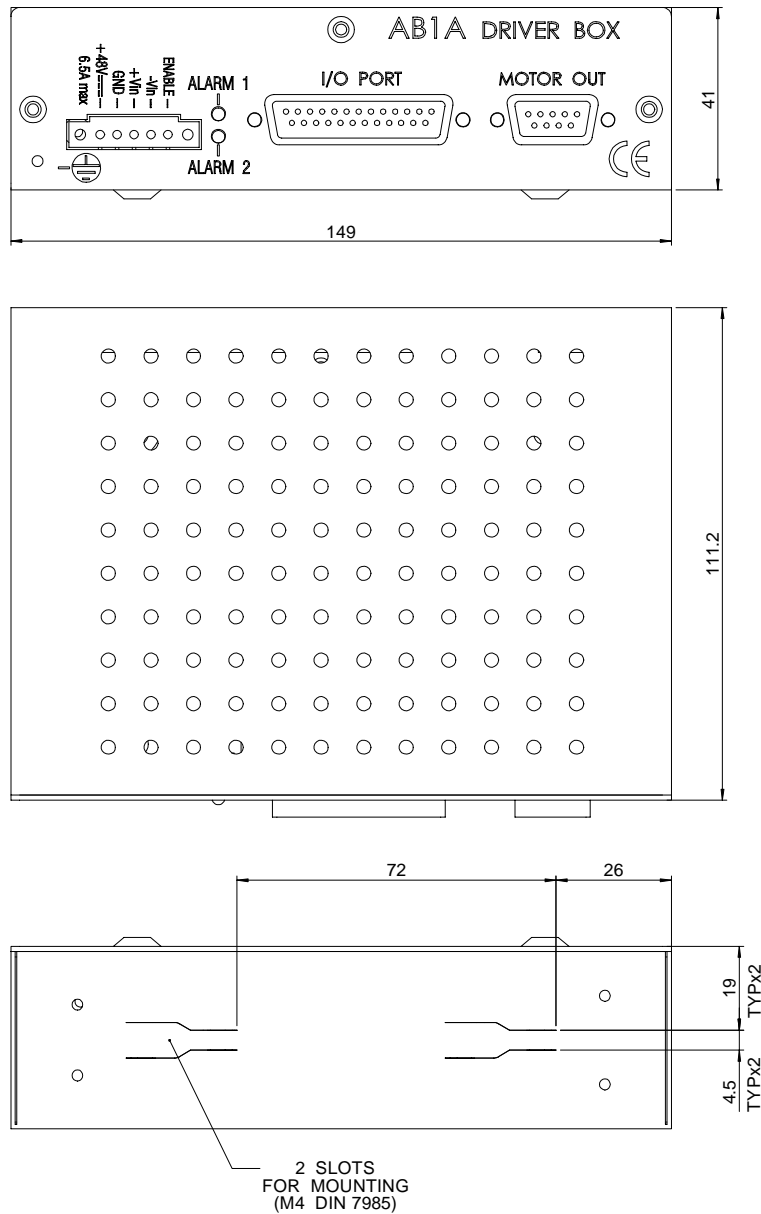

Figure 13 : AB1A Mechanical Dimensions In mm.