



▶ Linear & Rotary Positioning Stages



▶ Gearmotors & Gearheads



▶ Servo Motors & Drives



Brushless Servo Motor Product Manual





BM Series Brushless Servo Motor

Product Manual

Rev: 6.0 / 0305
P/N: 12197008

Please check www.baysidemotion.com for latest revisions.

Product Manual

BM Series

Brushless Servo Motor Manual

Table Of Contents

I. Introduction	1
II. Packaging	1
III. Electrical Specification	2
Motor	
Encoder	
Resolver	
Brake	
IV. Mechanical Specifications	8
V. Motor / Signal Connections	11



I. Introduction

Thank you for purchasing the Bayside BM Series Brushless Servo Motor. The BM Series brushless servo motors are high performance rare earth based products providing exceptional torque and efficiency in a compact, rugged package.

This manual provides installation and maintenance information for the:

- BM60 Series
- BM90 Series
- BM115 Series
- BM142 Series

If there are any questions regarding the installation of your product, please contact Bayside Motion Group Technical Services at (516)484-5353, for additional support.

II. Packaging

Standard servo motors are wrapped in plastic and packaged in a cardboard box, with environmentally safe, foam-in-place padding. The cardboard box may be recycled and the packing material can be disposed of normally. In some cases, quantity shipments may be provided in wooden crates.

Standard servo motors will arrive with a key pressed into the output shaft. If the key must be removed, do not apply shock loading to the output shaft. The motor can also be ordered without the key.

III. Electrical Specifications

Motor

Standard motors are provided with a single or double stack motor winding, for 160 vdc or 300 vdc operation. To identify the specific winding please refer to the following model number definition.

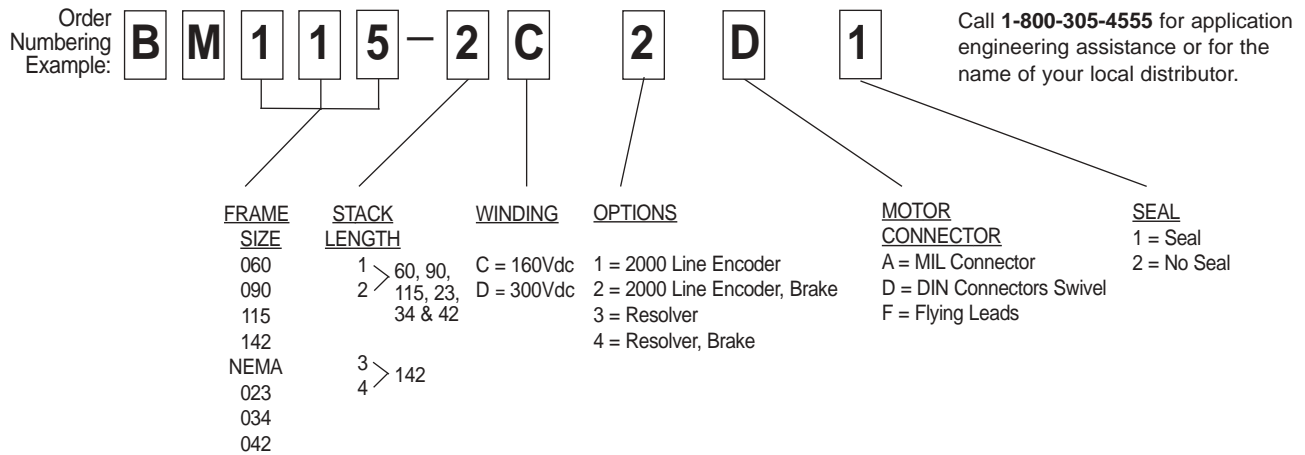

Performance Specifications

Frame Size	Motor Constant K_m		Continuous Torque T_c		Peak Torque T_p		Max. Speed (RPM)	Torque Constant K_T		Voltage Constant K_E		Cont. Current I_C (amps)	Peak Current I_P (amps)
	(Nm / \sqrt{W})	(oz in / \sqrt{W})	(Nm)	(oz in)	(Nm)	(oz in)		(Nm / amp)	(oz in / amp)	(V/rad/sec)	(V / kRPM)		
BM060-1	0.082	11.6	0.54	77	1.63	231	5400	0.28	39.6	0.28	29.3	2	6
BM060-1	0.082	11.6	0.54	77	1.63	231	5000	0.57	80.1	0.57	59.3	1	3
BM060-2	0.129	18.3	0.86	122	2.58	366	5400	0.28	39.6	0.28	29.3	3	9
BM060-2	0.129	18.3	0.86	122	2.58	366	5100	0.56	79.2	0.56	58.6	2	5
BM090-1	0.206	29.2	1.86	263	5.57	789	4600	0.33	46.1	0.33	34.1	6	17
BM090-1	0.206	29.2	1.86	263	5.57	789	4400	0.65	92.2	0.65	68.2	3	9
BM090-2	0.329	46.6	2.97	420	8.90	1260	3600	0.42	59.9	0.42	44.3	7	21
BM090-2	0.329	46.6	2.97	420	8.90	1260	3500	0.81	115	0.81	85.2	4	11
BM115-1	0.392	55.6	4.65	659	14.0	1977	3500	0.43	61.6	0.43	45.6	11	38
BM115-1	0.392	55.6	4.65	659	14.0	1977	3400	0.83	118	0.83	87.6	6	17
BM115-2	0.627	88.9	7.92	1122	23.8	3366	2800	0.54	75.8	0.54	56.1	15	44
BM115-2	0.627	88.9	7.92	1122	23.8	3366	3200	0.87	123	0.87	91.1	9	27
BM142-3	1.03	146.8	12.5	1766	37.4	5298	4500	0.61	86.9	0.61	64.2	20	61
BM142-4	1.62	230.4	21.9	3103	66.0	9309	3000	0.92	130.4	0.92	96.4	24	72

Frame Size	Resistance	Inductance	Winding (1)	Thermal Resistance	Core Loss	Elec. Time Constant	Mech. Time Constant	Pole Count
	R (ohms)	L (mH)	C:160 Vdc D:300 Vdc	θ (°C / W)	W @ 1 kRPM	(m sec)	(m sec)	#
BM060-1	11.8	12.5	C	1.93	0.74	1.1	1.5	6
BM060-1	48.3	51.2	D	1.93	0.74	1.1	1.5	6
BM060-2	4.8	6.2	C	1.93	1.48	1.3	0.93	6
BM060-2	19.0	25.0	D	1.93	1.48	1.3	0.93	6
BM090-1	2.5	4.5	C	1.06	2.37	1.8	1.4	8
BM090-1	10.1	18.1	D	1.06	2.37	1.8	1.4	8
BM090-2	1.6	3.8	C	1.06	4.74	2.4	0.67	8
BM090-2	6.3	14.1	D	1.06	4.74	2.4	0.67	8
BM115-1	1.2	2.9	C	0.61	6.7	2.4	1.5	12
BM115-1	4.7	10.7	D	0.61	6.7	2.4	1.5	12
BM115-2	0.73	2.2	C	0.61	13.4	3	1.1	12
BM115-2	1.9	5.8	D	0.61	13.4	3	1.1	12
BM142-3	0.35	2.1	D	0.5	24	6	1.2	12
BM142-4	0.34	2.3	D	0.45	48	6.8	0.9	12

(1) All winding can be operated at alternate bus voltages up to 500 Vdc.
The no load speed will vary proportionally with the change in voltage.

BM060
Single Stack

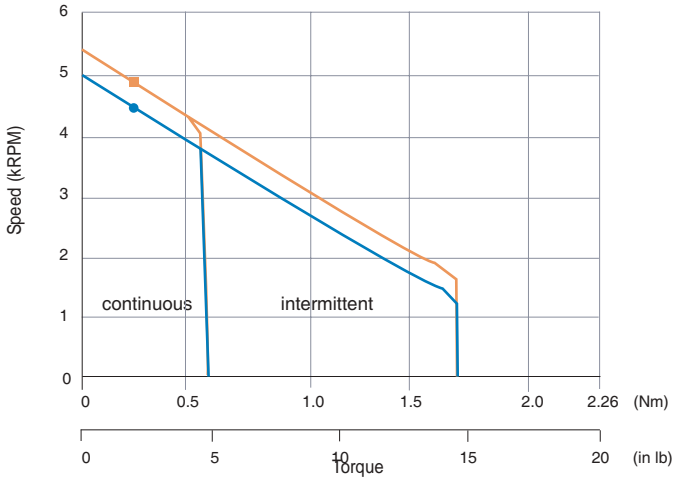

BM090
Single Stack

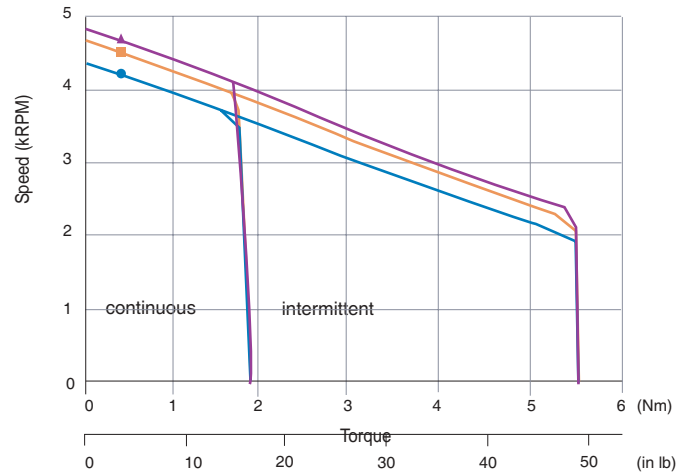

BM060
Double Stack

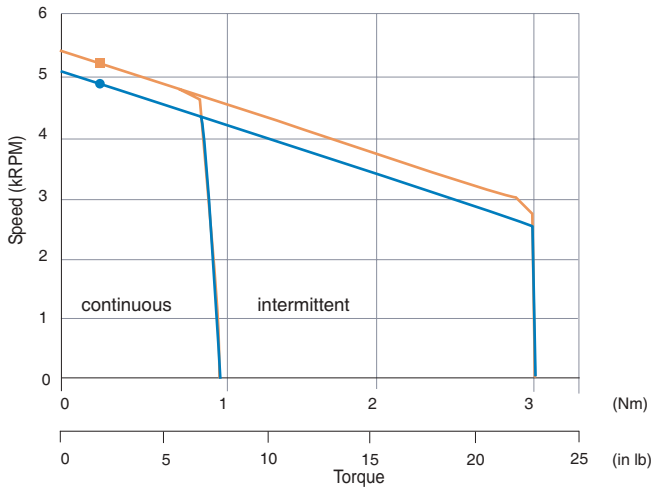

BM090
Double Stack

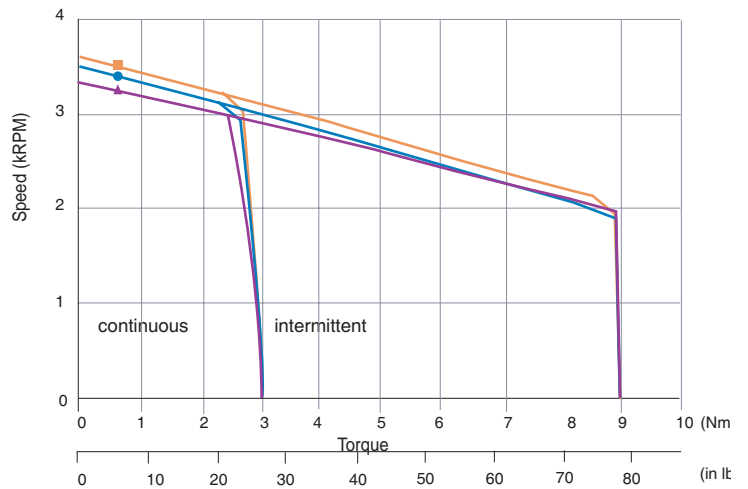

BM60

Continuous rated stall torque is with motor mounted on a 203mm x 203mm x 13mm (8in x 8in x 0.5in) aluminum plate in a 25°C ambient, with the winding at 155°C.

BM90

Continuous rated stall torque is with motor mounted on a 254mm x 254mm x 13mm (10in x 10in x 0.5in) aluminum plate in a 25°C ambient, with the winding at 155°C.

BM115
Single Stack

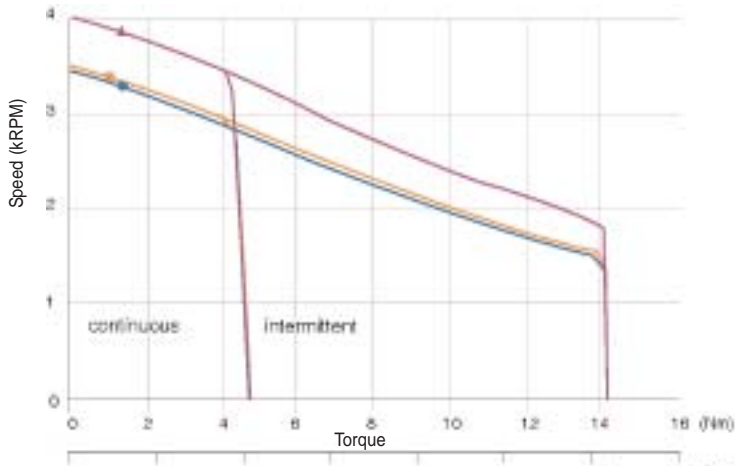

BM142
Single Stack

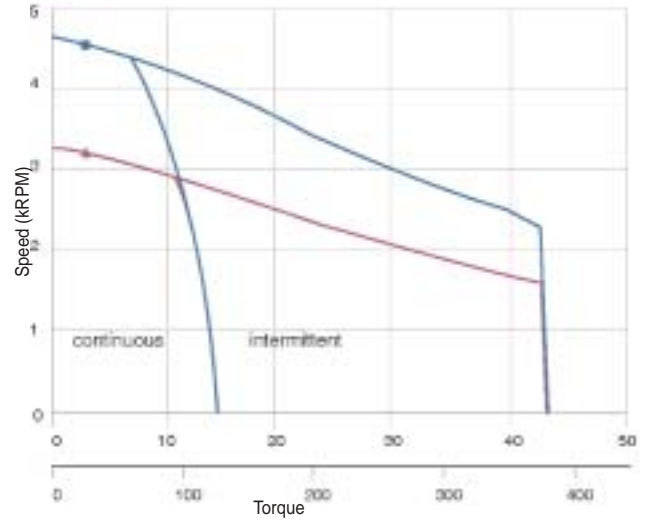

BM115
Double Stack

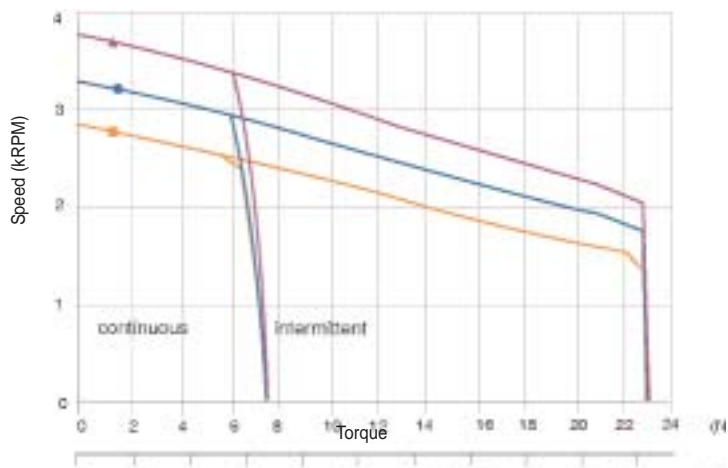

BM142
Double Stack

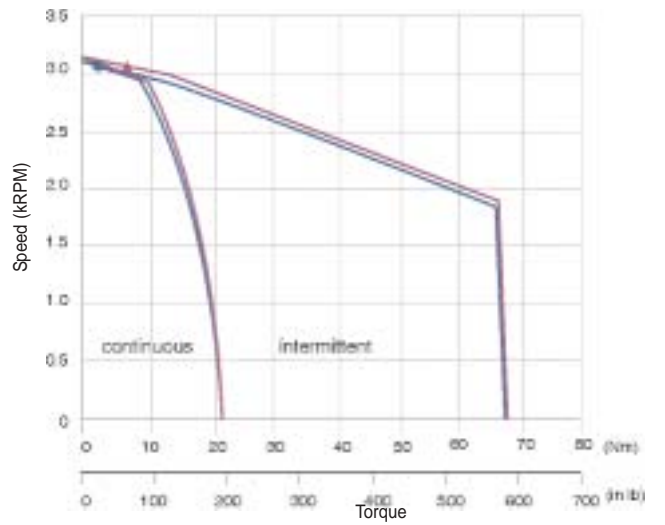

BM115
Continuous rated stall torque is with motor mounted on a 305mm x 305mm x 13mm (12in x 12in x 0.5in) aluminum plate in a 25°C ambient, with the winding at 155°C.

BM142
Continuous rated stall torque is with motor mounted on a 381mm x 381mm x 13mm (15in x 15in x 0.5in) aluminum plate in a 25°C ambient, with the winding at 155°C.

Maximum case temperature: Maximum case temperature depends on RMS motor dissipation, mounting surface temperature and ambient temperature.

All motor speed/torque curves and ratings are based on 25 deg C ambient with a winding temperature of 155 deg C, at stall. Ambient temperatures above 25 deg C will require de-rating. Consult Bayside Motion Group Technical Services at (516) 484-5353 for application assistance.

Encoder Specifications

(All Frame Sizes)

2000 Line Rotary Encoder	8,000 counts/rev Post Quadrature
Electrical Input	5 Vdc, 125 ma maximum (plus interface loads)
Encoder Output	A, B, I, \bar{A} , \bar{B} , \bar{I} Square wave, Diff. Frequency Response 125 KHz
Environmental Conditions	
Operating Temperature	-40 to 100 deg C
Storage Temperature	-40 to 100 deg C

Signal Timing

The following chart shows the timing of the commutation signals in relation to the motor bembf. See section IV, Wiring, for signal pin designations.

Motor Signal Timing (C/D winding)
at motor cable lead end

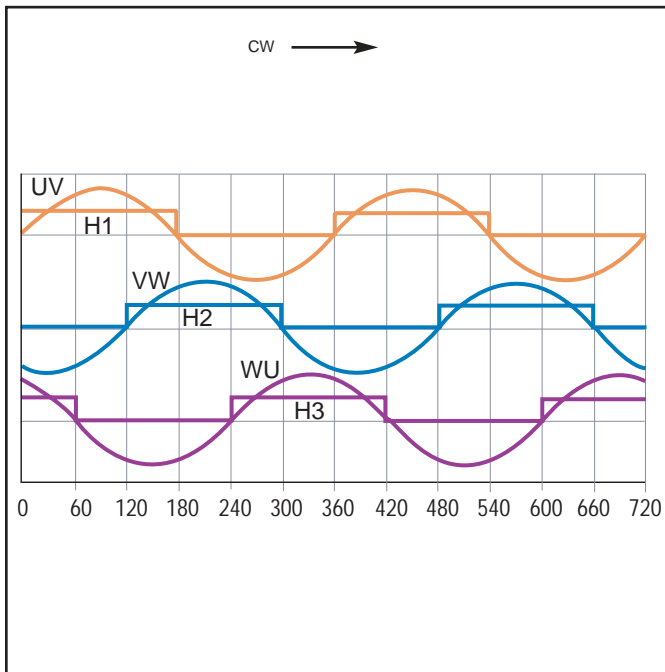

Encoder Timing

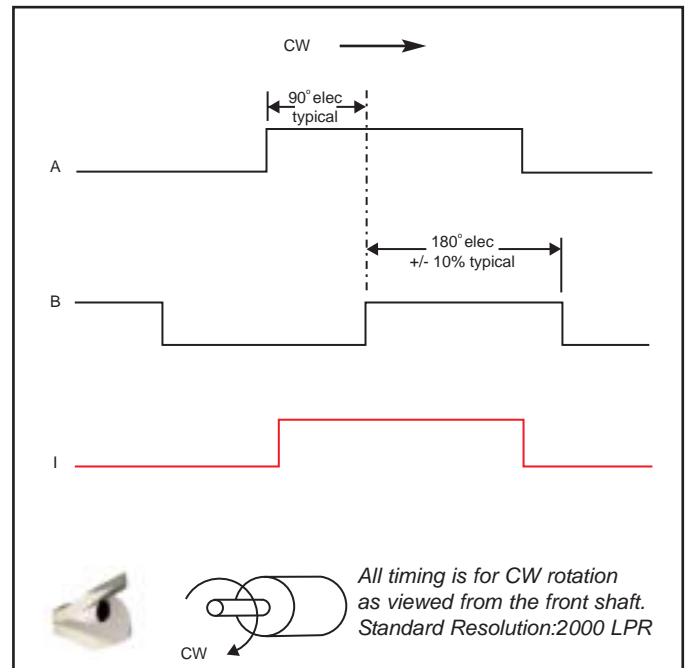

Resolver

The standard brushless resolver is for use with typical R/D (resolver to digital) converters. The resolver is a single cycle type, having 1 resolver cycle per revolution of the motor shaft.

Electrical Characteristics

Frequency	Hz	5,000
Input Voltage	Vrms	4.0
Input Current	ma max.	23
Input Power	Watts nom.	0.045
Transformation Ratio	± 10%	0.50
Output Voltage	Vrms	2.0
Sensitivity	mv / Deg	35

Environmental Conditions

Operating Temperature -55 to 155 deg C

Signal Timing

The start of the S1-S3 resolver signal is coincident with the start of the X-Y bemf motor signal.

Brake

The brake is fail safe type, i.e. braking action occurs when power is removed. Therefore, for motor rotation, the brake must be electrically energized.

Electrical Characteristics

Frame Size	Static Holding Torque		Voltage (V)	Current (amps)	Res (ohms)
	(Nm)	(in lb)			
BM060	0.33	3.0	24 Vdc	0.19	131
BM090	5.64	50	24 Vdc	0.30	65
BM115	5.64	50	24 Vdc	0.30	65
BM142	20	180	120 Vac	0.25	—

IV. Mechanical Specifications

Dimensions

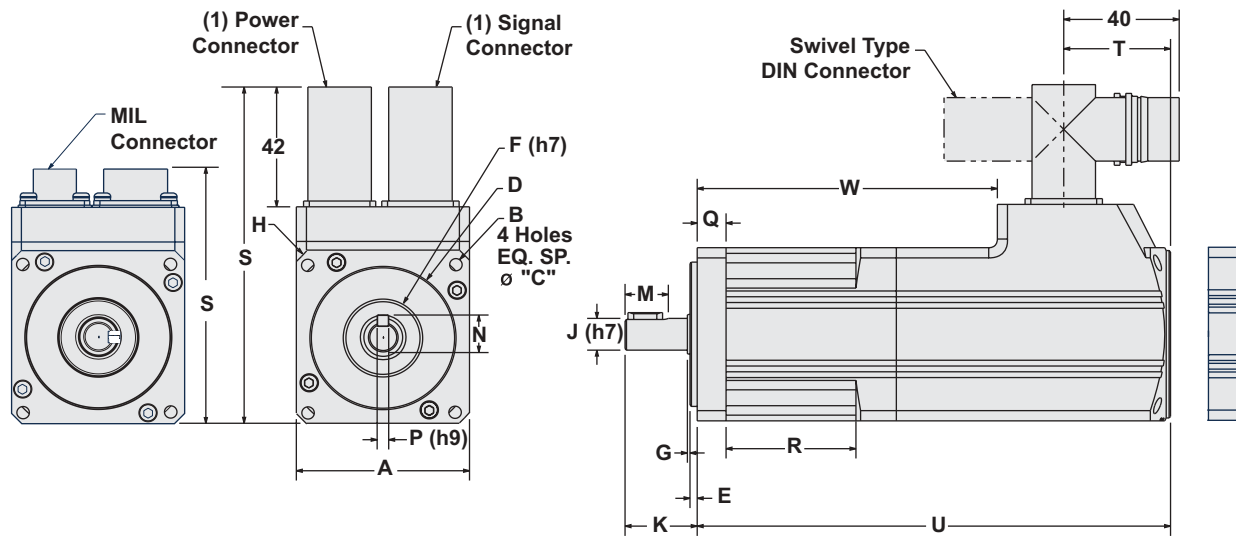

METRIC SIZES

Frame Size	A Square Flange		B Bolt Hole		C Bolt Circle Diameter		D Pilot Diameter		E Pilot Thickness		F Shoulder Diameter		G Shoulder Height		H Housing Diameter	
	(mm)	(in)	(mm)	(in)	(mm)	(in)	(mm)	(in)	(mm)	(in)	(mm)	(in)	(mm)	(in)	(mm)	(in)
BM060	60	2.36	5.5	0.217	70	2.76	50	1.97	2.5	0.098	14	0.551	1	0.039	80	3.15
BM090	90	3.54	6.5	0.256	100	3.94	80	3.15	3	0.118	19	0.748	1	0.039	120.5	4.74
BM115	115	4.53	8.5	0.335	130	5.12	110	4.33	3.5	0.138	25.4	1.00	1	0.039	152	5.98
BM142	142	5.59	11	0.433	165	6.50	130	5.12	3.5	0.138	25.4	1.00	1	0.039	194	7.64

Frame Size	J Shaft Diameter		K Shaft Length		M Keyway Length		N Keyway Height		P Keyway Width		Q Flange Thickness		S Height		T Connector Location	
	(mm)	(in)	(mm)	(in)	(mm)	(in)	(mm)	(in)	(mm)	(in)	(mm)	(in)	(mm)	(in)	(mm)	(in)
BM060	11	0.433	25	0.984	15	0.591	13.0	0.511	4	0.157	10	0.394	117	4.61	37	1.46
BM090	14	0.551	30	1.18	20	0.787	16.5	0.650	5	0.197	13	0.512	147	5.79	39	1.54
BM115	19	0.748	50	1.97	35	1.38	22.0	0.866	6	0.236	15	0.591	175	6.89	46	1.81
BM142	24	0.945	50	1.97	35	1.38	24.7	0.972	8	0.315	18	0.709	181.3	7.14	45 ⁽¹⁾	1.77

NEMA SIZES

Frame Size	B Bolt Hole		C Bolt Circle		D Pilot Diameter		J Output Shaft		K Output Shaft		M Keyway Length		N Keyway Height		P Keyway Width	
	(mm)	(in)	(mm)	(in)	(mm)	(in)	(mm)	(in)	(mm)	(in)	(mm)	(in)	(mm)	(in)	(mm)	(in)
BM023	0.195	5.0	2.625	66.7	1.500	38.1	0.375	9.5	1.000	25.4	0.750 flat	19.1 flat	0.015 flat	0.4 flat	—	—
BM034	0.218	5.5	3.875	98.4	2.875	73.0	0.500	12.7	1.250	31.8	1.063	27.0	0.072	1.8	0.125	3.2
BM042	0.281	7.1	4.950	125.7	2.187	55.5	0.625	15.9	1.500	38.1	1.130	28.7	0.108	2.7	0.188	4.8

Weight

Frame Size	Stack Length	Without Brake		With Brake	
		(kg)	(oz)	(kg)	(oz)
BM060	1	1.5	53	1.8	63
BM060	1	1.5	53	1.8	63
BM060	2	2.1	74	2.4	85
BM060	2	2.1	74	2.4	85
BM090	1	3.5	123	4.3	152
BM090	1	3.5	123	4.3	152
BM090	2	4.8	169	5.6	198
BM090	2	4.8	169	5.6	198
BM115	1	4.7	166	5.7	201
BM115	1	4.7	166	5.7	201
BM115	2	5.6	198	6.9	243
BM115	2	5.6	198	6.9	243
BM142	3	14.8	522	18.6	656
BM142	4	22	776	25.8	910

Inertia

Frame Size	Stack Length	Without Brake		With Brake	
		(gm cm sec ²)	(oz in sec ²)	(gm cm sec ²)	(oz in sec ²)
BM060	1	0.093	0.0013	0.098	0.0014
BM060	1	0.093	0.0013	0.098	0.0014
BM060	2	0.149	0.0021	0.154	0.0022
BM060	2	0.149	0.0021	0.154	0.0022
BM090	1	0.558	0.0078	0.593	0.0082
BM090	1	0.558	0.0078	0.593	0.0082
BM090	2	0.71	0.0099	0.745	0.0103
BM090	2	0.71	0.0099	0.745	0.0103
BM115	1	2.37	0.0329	2.4	0.0333
BM115	1	2.37	0.0329	2.4	0.0333
BM115	2	4.28	0.059	4.31	0.06
BM115	2	4.28	0.059	4.31	0.06
BM142	3	11.8	0.164	12.8	0.178
BM142	4	22.8	0.317	23.8	0.331

Options	U		V		W		R	
	Length		Rear Cover Length		Flange Offset		Recess Length	
	(mm)	(in)	(mm)	(in)	(mm)	(in)	(mm)	(in)
BM060 Single Stack – Encoder or Resolver	139	5.47	70	2.76	72	2.83	45	1.77
BM060 Single Stack – Encoder or Resolver and Brake	164	6.46	95	3.74	94	3.70	45	1.77
BM060 Double Stack – Encoder or Resolver	177	6.97	70	2.76	110	4.33	75	2.95
BM060 Double Stack – Encoder or Resolver and Brake	202	7.95	95	3.74	132	5.20	75	2.95
BM090 Single Stack – Encoder or Resolver	154	6.06	83	3.27	95	3.74	45	1.77
BM090 Single Stack – Encoder or Resolver and Brake	182	7.17	111	4.37	123	4.84	45	1.77
BM090 Double Stack – Encoder or Resolver	192	7.56	83	3.27	133	5.24	65	2.56
BM090 Double Stack – Encoder or Resolver and Brake	220	8.66	111	4.37	161	6.34	65	2.56
BM115 Single Stack – Encoder or Resolver	155	6.10	70	2.76	95	3.74	49	1.93
BM115 Single Stack – Encoder or Resolver and Brake	188	7.40	103	4.06	118	4.65	49	1.93
BM115 Double Stack – Encoder or Resolver	193	7.60	70	2.76	133	5.24	79	3.11
BM115 Double Stack – Encoder or Resolver and Brake	226	8.90	103	4.06	156	6.14	79	3.11
BM142 Single Stack – Encoder or Resolver	208	8.18	75.4	2.97	140	5.53	75	2.95
BM142 Single Stack – Encoder or Resolver and Brake	243	9.56	110.4	4.35	144	5.69	75	2.95
BM142 Double Stack – Encoder or Resolver	271	10.7	75.4	2.97	186	7.32	105	4.13
BM142 Double Stack – Encoder or Resolver and Brake	306	12.1	110.4	4.35	208	8.19	105	4.13

Motor Power Connection
(DIN Connector)

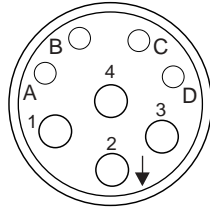

Power Connector Details

Pin Number	Function	Mating Cable Color Code
3	U	Black #1
1	V	Black #2
4	W	Black #3
2	Chassis Gnd.	Yellow / Green
A	Thermistor +	Black #5
B	Thermistor -	Black #6
C	Brake +	Black #7
D	Brake -	Black #8
-	Shield	Drain

Motor Power Mating Connector

Manufacturer	Part Number	Description
Hypertac	LPNA08BFRKB170	Body
	020.232.2000	4 Pins Female 18-26 AWG
	020.090.1020	4 Pins Female 16-20 AWG

Cables



Mating Power Cable

Part Number	Length	Used With
10963093	3 meter	Flying Leads
10963117	8 meter	Flying Leads

Motor Sensor Connector (DIN Connector)

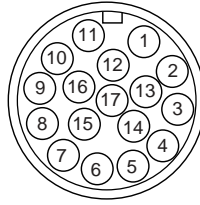

Pin Number	Function		Mating Cable	
	Encoder	Resolver	Flying Lead Color Code	i-Drive Conn. Pin Number
1	A +	S1 (SIN+)	Black	1
2	B +	S4 (COS+)	Red	2
7	+5V	R2 (Ref+)	Brown/Green	7
8	Shield	Shield	Shield	8
9	A -	S3 (SIN-)	Violet	9
10	B -	S2 (COS-)	Blue	10
15	Gnd	R1 (REF-)	White/Green	15
12	Spare	Spare	Gray/Pink	—
5	I +	—	Brown	5
13	I -	—	White	13
3	Hall 1 (S1)	—	Yellow	—
11	Hall 2 (S2)	—	Green	—
4	Hall 3 (S3)	—	Red/Blue	—
16	Thermistor +	Thermistor +	White/Yellow	—
17	Thermistor -	Thermistor -	Yellow/Brown	—
6 & 14	No Connection			

Motor Sensor Mating Connector

Manufacturer	Part Number	Description
Hypertac	SPNA17HFRON	Body
	020.256.1020	17 Pins Female

Cables



Mating Sensor Cable

Part Number	Length	Used With
10963094	3 meter	Flying Leads
10963096	3 meter	i-Drive
10963123	8 meter	Flying Leads
10963118	8 meter	i-Drive
10963136 ⁽¹⁾	N / A	i-Drive / Controller

(1) NOTE: When an external controller is used in a closed loop mode an additional sensor cable, part number 10963136, is required.

Motor Power/Sensor Connections (Flying Lead option)

Sensor Wiring Details

Function		Wire Color
Encoder	Resolver	
A +	S1 (SIN+)	Brown
B +	S4 (COS+)	Blue
+5V	R2 (Ref+)	Red
Shield	Shield	Shield
A -	S3 (SIN-)	White
B -	S2 (COS-)	Green
Gnd	R1 (REF-)	Black
Spare	Spare	-
I +	—	Orange
I -	—	Yellow
Hall 1 (S1)	—	White/Brown
Hall 2 (S2)	—	White/Orange
Hall 3 (S3)	—	Violet
Thermistor +	Thermistor +	White/Red
Thermistor -	Thermistor -	White/Black
No Connection		

Power Wiring Details

Function	Color
U	White
V	Black
W	Red

IV. Wiring

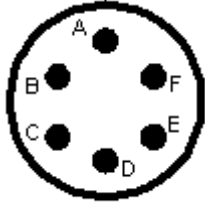

**060 Serial Motor Power connector
(MIL Connector)**

**090/115/142 Serial Motor Power connector
(MIL Connector)**

Power Connector Details

Power Connector Details

Pin Number	Function	Mating Cable Color Code
A	U	Red
B	V	Black
C	W	White
D	Chassis Gnd.	Green
E	Brake +	Orange
F	Brake -	Blue
--	Shield	Drain

Pin Number	Function	Mating Cable Color Code
A	U	Black #1
B	V	Black #2
C	W	Black #3
D	Chassis Gnd.	GRN/YLW
E	Brake +	Black #4
F	Brake -	Black #5
G	Spare	--
--	Spare	Black #6
--	Shield	Drain

Motor Power Mating Connector

Motor Power Mating Connector

Manufacturer	Part Number	Description
Connon/ITT Industries	KPT06J106S	North America Circular MIL - C - 26482 Series I KPT / KPSE

Manufacturer	Part Number	Description
Connon/ITT Industries	CA3106E20-15S-B	Euro Circular CA-Bayonet/VG95234 Circular Signal and Power Connectors

Cables

Cables



Mating Power Cable

Mating Power Cable

Part Number	Length	Used With
10963012_3000	3 meter	Flying Leads
10963013_8000	8 meter	Flying Leads

Part Number	Length	Used With
10963021_3000	3 meter	Flying Leads
10963021_8000	8 meter	Flying Leads

060/090/115/142 Motor Sensor Connector
(MIL Connector)

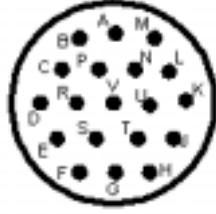

Pin Number	Function	Mating Cable	
		Flying Lead Color Code	i-Drive Conn. Pin Number
E	A +	Orange	1
A	A-	Black w/Org	9
F	B+	Yellow	2
J	B-	Black w/Ylw	10
H	I+	Blue	5
K	I-	Black w/Blue	13
B	Hall 1	White	-
C	Hall 2	Green	-
D	Hall3	Brown	-
L	+5V	Red	7
N	GND	Black w/Red	15
M	T1	Black w/White	-
P	T2	Black w/Grn	-
S	Spare	Black w/Brn	-
SHIELD	Shield	Drain	8

Pin Number	Function	Mating Cable for Resolver
		Flying Lead Color Code
A	R1 (Ref+)	Black w/Red
E	R2 (Ref-)	Red
J	S1 (Cos+)	Black w/Wht
K	S3 (Cos-)	White
F	S2 (Sin+)	Black w/Grn
H	S4 (Sin-)	Green
M	T1	Black w/Blue
P	T2	Blue
Shield	Shield	Drain

Motor Sensor Mating Connector

Manufacturer	Part Number	Description
Connon/ITT Industries	KPT06J1419S	North America Circular MIL-C-26482 Series I KPT/KPSE

Cables



Mating Sensor Cable

Part Number	Length	Used With
10963011_3000	3 meter	Flying Leads/Encoder
10963119_3000	3 meter	i-Drive/Encoder
10963011_8000	8 meter	Flying Leads/Encoder
10963119_8000	8 meter	i-Drive/Encoder
10963073_3000	3 meter	Flying Leads/Resolver
10963073_8000	8 meter	Flying Leads/Resolver
10963136 ⁽¹⁾	0.3+0.3 meter	i-Drive / Controller

(1) NOTE: When an external controller is used in a closed loop mode an additional sensor cable, part number 10963136, is required.